

*BOARD OF COUNTY COMMISSIONERS
WARREN COUNTY, OHIO*

Resolution

Number 19-1060

Adopted Date August 20, 2019

ACCEPT RESIGNATION, WYATT ALLEN, WATER DISTRIBUTION WORKER I, WITHIN THE WARREN COUNTY WATER AND SEWER DEPARTMENT, EFFECTIVE AUGUST 23, 2019

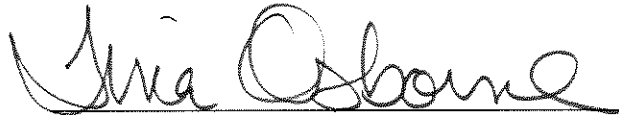
BE IT RESOLVED, to accept the resignation, of Wyatt Allen, Water Distribution Worker I, within the Warren County Water and Sewer Department, effective August 23, 2019.

Mr. Young moved for adoption of the foregoing resolution being seconded by Mr. Grossmann. Upon call of the roll, the following vote resulted:

Mrs. Jones – yea
Mr. Grossmann – yea
Mr. Young – yea

Resolution adopted this 20th day of August 2019.

BOARD OF COUNTY COMMISSIONERS



Tina Osborne, Clerk

cc: Water/Sewer (file)
W. Allen's Personnel File
OMB – Sue Spencer
Tammy Whitaker

*BOARD OF COUNTY COMMISSIONERS
WARREN COUNTY, OHIO*

Resolution

Number 19-1061

Adopted Date August 20, 2019

ACCEPT RESIGNATION, DUE TO RETIREMENT, OF LISA SHUTTS, ASSISTANT BUSINESS MANAGER, WITHIN THE WARREN COUNTY WATER AND SEWER DEPARTMENT, EFFECTIVE AUGUST, 31, 2019

BE IT RESOLVED, to accept the resignation, due to retirement, of Lisa Shutts, Assistant Business Manager, within the Warren County Water and Sewer Department, effective August 31, 2019.

Mr. Young moved for adoption of the foregoing resolution being seconded by Mr. Grossmann. Upon call of the roll, the following vote resulted:

Mrs. Jones – yea
Mr. Grossmann – yea
Mr. Young – yea

Resolution adopted this 20th day of August 2019.

BOARD OF COUNTY COMMISSIONERS



Tina Osborne, Clerk

cc: Water/Sewer (file)
Lisa Shutts' Personnel File
OMB – Sue Spencer
Tammy Whitaker

Resolution

Number 19-1062

Adopted Date August 20, 2019

ACCEPT RESIGNATION OF OLIVIA TAYLOR, PROTECTIVE SERVICES CASEWORKER II, WITHIN THE WARREN COUNTY DEPARTMENT OF JOB AND FAMILY SERVICES, CHILDREN SERVICES DIVISION, EFFECTIVE AUGUST 23, 2019

BE IT RESOLVED, to accept the resignation, of Olivia Taylor, Protective Services Caseworker II, within the Warren County Department of Job and Family Services, Children Services Division, effective August 23, 2019.

Mr. Young moved for adoption of the foregoing resolution being seconded by Mr. Grossmann. Upon call of the roll, the following vote resulted:

Mrs. Jones – yea
Mr. Grossmann – yea
Mr. Young – yea

Resolution adopted this 20th day of August 2019.

BOARD OF COUNTY COMMISSIONERS



Tina Osborne, Clerk

cc: Children Services (file)
O. Taylor's Personnel File
OMB – Sue Spencer
Tammy Whitaker

Resolution

Number 19-1063

Adopted Date August 20, 2019

APPROVE RECLASSIFICATION OF KRISTIN THOMAS TEMPORARY YOUTH EMPLOYMENT WORKSITE SUPERVISOR TO THE POSITION OF CUSTOMER ADVOCATE I WITHIN OHIO MEANS JOBS WARREN COUNTY

WHEREAS, the Director has indicated an additional Customer Advocate is needed to work with the youth program and he desires to reclassify Ms. Thomas to said position as she has worked with the summer youth program and will continue to work with the same clientele; and

NOW THEREFORE BE IT RESOLVED, to reclassify Kristin Thomas from the position of Temporary Youth Employment Worksite Supervisor to Customer Advocate I, within OhioMeansJobs Warren County, permanent, non-exempt, pay range #14, \$15.76 per hour, effective pay period beginning August 31, 2019.

Mr. Young moved for adoption of the foregoing resolution being seconded by Mr. Grossmann. Upon call of the roll, the following vote resulted:

Mrs. Jones – yea
Mr. Grossmann – yea
Mr. Young – yea

Resolution adopted this 20th day of August 2019.

BOARD OF COUNTY COMMISSIONERS


Tina Osborne, Clerk

cc: OhioMeansJobs (file)
K. Thoms' Personnel file
OMB-Sue Spencer

Resolution

Number 19-1064

Adopted Date August 20, 2019

APPROVE END OF 365-DAY PROBATIONARY PERIOD AND APPROVE A PAY INCREASE FOR JOSHUA HISLE WITHIN WARREN COUNTY DEPARTMENT OF OHIOMEANSJOBS

WHEREAS, Joshua Hisle, Customer Advocate I within Warren County Department of OhioMeansJobs, has successfully completed a 365-day probationary period, effective August 23, 2019; and

NOW THEREFORE BE IT RESOLVED, to approve Joshua Hisle's completion of 365-day probationary period and to approve a pay increase to end of probationary rate of \$16.23 per hour effective pay period beginning August 31, 2019.

Mr. Young moved for adoption of the foregoing resolution being seconded by Mr. Grossmann. Upon call of the roll, the following vote resulted:

Mrs. Jones – yea
Mr. Grossmann – yea
Mr. Young – yea

Resolution adopted this 20th day of August 2019.

BOARD OF COUNTY COMMISSIONERS



Tina Osborne, Clerk

cc: OhioMeansJobs (file)
J. Hisle's Personnel File
OMB – Sue Spencer

Resolution

Number 19-1065

Adopted Date August 20, 2019

APPROVE END OF 365-DAY PROBATIONARY PERIOD AND APPROVE A PAY INCREASE FOR BRENDAN CZINEGE WITHIN WARREN COUNTY WATER AND SEWER DEPARTMENT

WHEREAS, Brendan Czinege, Water Distribution Worker I within Warren County Water and Sewer Department, has successfully completed a 365-day probationary period, effective August 13, 2019; and

NOW THEREFORE BE IT RESOLVED, to approve Brendan Czinege's completion of 365-day probationary period and to approve a pay increase to end of probationary rate of \$15.94 per hour effective pay period beginning August 17, 2019.

Mr. Young moved for adoption of the foregoing resolution being seconded by Mr. Grossmann. Upon call of the roll, the following vote resulted:

Mrs. Jones – yea
Mr. Grossmann – yea
Mr. Young – yea

Resolution adopted this 20th day of August 2019.

BOARD OF COUNTY COMMISSIONERS


Tina Osborne, Clerk

cc: Water and Sewer (file)
B. Czinege's Personnel File
OMB – Sue Spencer

**BOARD OF COUNTY COMMISSIONERS
WARREN COUNTY, OHIO**

Resolution

Number 19-1066

Adopted Date August 20, 2019

APPROVE END OF 365-DAY PROBATIONARY PERIOD AND APPROVE A PAY INCREASE FOR DEVIN DAWSON WITHIN WARREN COUNTY DEPARTMENT OF FACILITIES MANAGEMENT

WHEREAS, Devin Dawson, Service Worker I within Warren County Department of Facilities Management, has successfully completed a 365-day probationary period, effective August 13, 2019; and

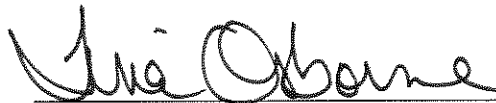
NOW THEREFORE BE IT RESOLVED, to approve Devin Dawson's completion of 365-day probationary period and to approve a pay increase to end of probationary rate of \$15.56 per hour effective pay period beginning August 17, 2019.

Mr. Young moved for adoption of the foregoing resolution being seconded by Mr. Grossmann. Upon call of the roll, the following vote resulted:

Mrs. Jones – yea
Mr. Grossmann – yea
Mr. Young – yea

Resolution adopted this 20th day of August 2019.

BOARD OF COUNTY COMMISSIONERS



Tina Osborne, Clerk

cc: Facilities Management (file)
D. Dawson's Personnel File
OMB – Sue Spencer

*BOARD OF COUNTY COMMISSIONERS
WARREN COUNTY, OHIO*

Resolution

Number 19-1067

Adopted Date August 20, 2019

ENTER INTO AGREEMENT WITH CINCINNATI BELL TELEPHONE COMPANY, LLC
ON BEHALF OF WARREN COUNTY TELECOMMUNICATIONS

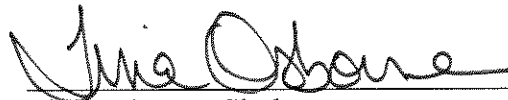
BE IT RESOLVED, to approve an agreement with Cincinnati Bell Telephone Company, LLC.
for telephone service on behalf of Warren County Telecommunications; copy of agreement
attached hereto and a part hereof.

Mr. Young moved for adoption of the foregoing resolution being seconded by Mr. Grossmann.
Upon call of the roll, the following vote resulted:

Mrs. Jones – yea
Mr. Grossmann – yea
Mr. Young – yea

Resolution adopted this 20th day of August 2019.

BOARD OF COUNTY COMMISSIONERS



Tina Osborne, Clerk

cc: c/a- Cincinnati Bell Telephone Company, LLC
Telecom (file)

SERVICES AGREEMENT

Agreement Number: 02450769

Customer Warren County Telecommunications			Service Provider Cincinnati Bell Telephone Company LLC ("Cincinnati Bell")		
Address 500 Justice Drive			Address 221 East Fourth Street P.O. Box 2301		
City Lebanon	State OH	Zip Code 45036	City Cincinnati	State OH	Zip Code 45201
<p>THIS CINCINNATI BELL SERVICES AGREEMENT IS SUBJECT TO THE GENERAL TERMS AND CONDITIONS AND APPLICABLE SERVICES SUPPLEMENTS ATTACHED HERETO (COLLECTIVELY "TERMS AND CONDITIONS"). CINCINNATI BELL'S STANDARD TERMS AND CONDITIONS AND SUPPLEMENTS ARE AVAILABLE AT WWW.CINCINNATIBELL.COM/BUSINESS/LEGAL. BY EXECUTING THIS CINCINNATI BELL SERVICES AGREEMENT WHERE INDICATED BELOW, CUSTOMER ACKNOWLEDGES THAT CUSTOMER HAS READ, UNDERSTANDS, ACCEPTS AND AGREES TO BE BOUND BY ALL SUCH TERMS AND CONDITIONS. CUSTOMER'S SIGNATURE ACKNOWLEDGES AUTHORIZATION FOR CINCINNATI BELL TO REQUEST CREDIT INFORMATION FROM ANY CREDIT REPORTING AGENCY OR SOURCE.</p>					
<p>NOTES:</p> <ul style="list-style-type: none"> - The term "Cincinnati Bell" shall be deemed to mean the Service Provider on behalf of itself and its' affiliates. - The Agreement shall become effective on the latter of the provisioning or activation date ("Effective Date"). - In addition to the Services Agreement charges, Customers will incur all regulated charges mandated by the Regulatory Commissions with Jurisdiction over Cincinnati Bell. ADSL, Dedicated FUSE Internet Access, Evantage and EmERGE services are not subject to Regulatory Commission jurisdiction. - All prices and rates are exclusive of any surcharges and taxes. - Installation/One-time charge does not cover premise technician work outside of the hours of 8 a.m. to 5 p.m. - The service products, prices and terms identified on this Services Agreement constitutes Cincinnati Bell's offer to provide such services on such terms. Until Customer has accepted this offer by signing as appropriate above, Cincinnati Bell reserves the right to rescind this offer at any time, at its' sole discretion. - Facsimile signatures to this Services Agreement and any additional documents incorporated herein shall be deemed to be binding upon the parties. - Customer may cancel services any time after the first twelve (12) months without penalty by providing Cincinnati Bell 30 days advanced written notice. 					

Warren County Telecommunications

CINCINNATI BELL

Signature of Authorized Representative:

Signature of Authorized Representative:

Shannon Jones

J. Kathman

Printed Name: Shannon Jones

Printed Name: Jessica Kathman

Title: President

Title: Director of Sales

Date: 8-20-19

Date: 8/7/2019

APPROVED AS TO FORM

Adam M. Nice

**Adam M. Nice
Asst. Prosecuting Attorney**

SERVICE PRICING

ID	Service	Qty	Unit MRC	Unit NRC	Total MRC	Total NRC
1	Warren County Telecommunications, 500 Justice Dr, LEBANON, OH 45036 USA					
1.1	Product: Prime/Trunk Advantage Order Type: Acquisition - New Contract Term: 60 months					
1.1.1	Two Way/DID Channels	46	\$5	\$0	\$230.00	\$0.00
1.1.2	DID 20# Blocks	0	\$	\$	\$0.00	\$0.00
1.1.3	PRI Facility	2	\$185	\$0	\$370.00	\$0.00

Total Monthly Recurring Charge	\$600.00
Total One-Time Charge	\$0.00

Customer Initials	Date

PRIME ADVANTAGE – TERMS AND CONDITIONS SUPPLEMENT

1. TERM.

1.1. After expiration of the initial term as stated on the Services Agreement sheet, this Agreement shall automatically renew on a month-to-month basis subject to the then current month-to-month tariff /service agreement rates and the terms and conditions herein. Either Party may terminate the month-to-month service without termination penalty upon thirty (30) days advance written notice to the other Party. Hereinafter "Term" shall mean collectively Initial and/or Renewal Term. Notwithstanding the foregoing, Cincinnati Bell reserves the right to adjust rates (including but not limited to pricing and fees for equipment) at any time after the expiration of the Initial Term upon sixty (60) days prior written notice to Customer, during which time Customer shall have the right to terminate the Agreement, without incurring termination charges, if Customer does not agree to stated rate adjustment. In the event Customer does not provide written notice of termination during the sixty (60) day period and terminate services within the sixty (60) day period, Customer shall be deemed to accept the rate adjustment.

2. DEFINITIONS.

2.1. Prime Advantage – is a high-speed, high-capacity switched digital interface carrying 24 channels between the Customer's premise (ISDN-compatible, PBX, router, bridge, computer interface or other CPE) and a Cincinnati Bell central office. Each Prime Advantage facility consists of up to 23 bearer channel (B channels) for circuit-switched voice, video and data, and a separate delta channel (D channel) dedicated to perform monitoring and signaling for the B channels.

3. SERVICES AND RATES.

- 3.1. Prime Advantage service will be provided as specified on the attached Services Agreement.
- 3.2. If Customer cancels, in whole or in part, any requested installation, addition, rearrangement, relocation or other modification to Prime Advantage service prior to completion thereof, Customer will reimburse Cincinnati Bell for the actual expenses incurred by Cincinnati Bell in connection with such modification prior to Cincinnati Bell's receipt of notice of cancellation; provided, however, the amount of such reimbursement will not exceed the service, construction, installation, termination and other charges for which Customer would have otherwise been responsible.
- 3.3. Customer will be responsible for all taxes, surcharges, assessments or other charges (excluding taxes based on Cincinnati Bell's net income) imposed upon or relating to the provision or use of the products and services provided hereunder.
- 3.4. Any other regulated services not listed herein which are provided by Cincinnati Bell to Customer, shall be governed by the rates, terms, and conditions of the appropriate tariff / service agreement. Cincinnati Bell shall comply with all applicable laws, rules, regulations, ordinances, and codes (collectively, "Legal Requirements") in connection with the provision of the Prime Advantage service.

4. BILLING.

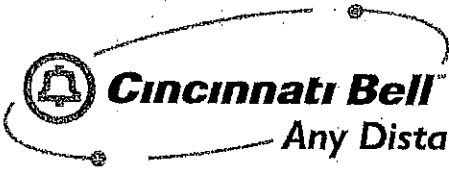
4.1. Customer agrees to timely pay all monthly bills. Any amount outstanding after the due date on the Customer bill shall be deemed a "past due balance". In the event of a disagreement about a Customer bill, Customer may contact Cincinnati Bell Customer Care at 513-566-5050. Customer satisfaction is of the utmost importance to Cincinnati Bell, and it is our policy to fully investigate and resolve, to our satisfaction, all customer billing disagreements lodged within 60 days of the original due date.

5. TERMINATION CHARGES.

- 5.1. In the event that Prime Advantage Service under this Agreement is terminated by Customer for convenience or for reasons other than Cincinnati Bell's breach of this Agreement prior to the expiration of the then-current Term, the Customer will pay a termination charge equal to all remaining amounts due or to become due, including but not limited to all monthly charges for which Customer would have been responsible if the Customer had not terminated prior to the expiration of the then-current Term.
- 5.2. If non-recurring charges associated with the installation of Prime Advantage service are waived and the Prime Advantage service is then terminated prior to the expiration of the initial Term, the Customer will become liable for payment of the waived charges.



Cincinnati Bell™



Cincinnati Bell™
Any Distance

Letter of Authorization for Local and/or Long Distance Telephone Service

Thank you for choosing Cincinnati Bell Telephone Company (CBT) as your local exchange carrier and / or Cincinnati Bell Any Distance (CBAD) as your long distance carrier. To begin providing service to you, CBT and CBAD are required to obtain proof that you have authorized a change in your telephone service from your current provider(s) to CBT and / or CBAD. This letter of authorization (LOA) also grants CBT and CBAD permission to access your customer service records as necessary and will be maintained by CBT and CBAD as a record of your order. Please complete this form and return it to CBT as soon as possible.

****IT IS STRONGLY RECOMMENDED THAT YOUR PHONE VENDOR IS ONSITE DURING THE INSTALLATION OF YOUR VOICE SERVICES.**

Name: FED TAX ID:

Title:

Name of Account / Business:

Address:

City: State: Zip:

I appoint CBT as the local exchange carrier and/or CBAD as the long distance carrier for the number(s) listed below. The identified number(s) is/are listed in my name and/or I am authorized to change the telephone service for the number(s). I authorize CBT to act as my agent to transfer all local exchange service(s) billed to my primary and secondary telephone number(s) from my current local exchange carrier to CBT. I authorize CBAD to be the long-distance provider for the number(s) listed below and appoint CBAD to act as my agent to ensure that my local telephone company makes the connections necessary for me to use CBAD service. I understand that service from my current local exchange and long distance carriers for the number(s) will be canceled as indicated below. I understand that my local telephone company may charge me a fee for changing my long distance provider to CBAD.

Primary Billing Telephone number:
Area code Telephone Number

Please list all billed telephone numbers for which CBT and CBAD are authorized to provide service. Also, please indicate the type of service requested—local exchange service, intraLATA service (i.e. "local" or in-region long distance), and interLATA (i.e. long distance service beyond the region).

() - Local Exchange () IntraLATA () InterLATA ()
Area code Telephone number

() - Local Exchange () IntraLATA () InterLATA ()
Area code Telephone number

() - Local Exchange () IntraLATA () InterLATA ()
Area code Telephone number

CBT and CBAD may use this information to process a credit check on all new customers. If sections of this form are not completed, your order may be delayed. Please contact 1-888-Cinbell (1-888-246-2355) Toll Free if you have questions.

Customer Signature:
Customer Print:

Date:
Date:

GENERAL TERMS AND CONDITIONS

1. DEFINITIONS.

1.1. The following definitions shall apply to this Agreement and, unless otherwise provided therein, shall also apply to the Supplements. The definitions shall apply equally to both the singular and plural forms of the terms defined. Whenever the context may require, any pronoun shall include the corresponding masculine, feminine and neuter forms. The words "include," "includes" and "including" shall be deemed to be followed by the phrase "without limitation". The words "shall" and "will" are used interchangeably throughout this Agreement and the use of either connotes a mandatory requirement. The use of one or the other shall not mean a different degree or right or obligation for either Party. The use of the term "Agreement" shall be deemed to refer to the entire agreement between the Parties consisting of this Agreement and includes each Supplement.

1.2. Applicable Laws - means all applicable federal, state, and local statutes, laws, rules, regulations, codes, final and non-appealable orders, decisions, injunctions, judgments, awards and decrees that relate to a Party's obligations under this Agreement.

1.3. Information - means any writing, drawing, sketch, model, sample, data, computer program, software, verbal communication, e-mail, recording or documentation of any kind.

1.4. Party - means (i) Cincinnati Bell parent company, its affiliates and subsidiaries (collectively "Cincinnati Bell") or (ii) Customer; and "Parties" means (i) and (ii).

1.5. Proprietary Information - means any Information communicated, whether before, on or after the Effective Date, by a Party ("Disclosing Party") to the other Party ("Receiving Party"), pursuant to this Agreement and if written, is marked "Confidential" or "Proprietary" or by similar notice or if oral or visual, is identified as "Confidential" or "Proprietary" at the time of disclosure; or if by electronic transmission (including, but not limited to, facsimile or electronic mail) in either human readable or machine readable form, and is clearly identified at the time of disclosure as being "Proprietary" or "Confidential" by an appropriate and conspicuous electronic marking within the electronic transmission, which marking is displayed in human readable form along with any display of the "Proprietary" or "Confidential" information; or if by delivery of an electronic storage medium or memory device which is clearly identified at the time of disclosure as containing "Proprietary" or "Confidential" information by an appropriate and conspicuous marking on the storage medium or memory device itself and by an appropriate and conspicuous electronic marking of the stored "Proprietary" or "Confidential" information, which marking is displayed in human readable form along with any display of the "Proprietary" or "Confidential" information. Notwithstanding any term of this agreement to the contrary, the parties acknowledge and agree that Customer is subject to Ohio Public Records laws and disclosing public records as defined and required to be disclosed pursuant to Section 149.43 of the Ohio Revised Code, even if the record is deemed proprietary or confidential by Cincinnati Bell or this agreement, shall not be violation or breach of any term of this agreement, Customer will notify Cincinnati Bell should any propriety or confidential information be subject to a public records request.

2. SERVICES.

2.1. The applicable rates, fees, commissions and charges for a particular service to be provided by Cincinnati Bell pursuant to the Supplement(s) will be on the Services Agreement sheet. Any other regulated services not listed on the Supplements which are provided by Cincinnati Bell to Customer shall be governed by the rates, terms, and conditions of the appropriate tariff. Cincinnati Bell shall comply with all applicable laws, rules, regulations, ordinances, and codes (collectively, "Legal Requirements") in connection with the provision of the Supplement Service. The specific terms and conditions applicable to the particular services to be provided pursuant to this Agreement, including the description of the services to be provided and the obligations of each Party in connection therewith, termination rights, performance obligations and service parameters are or shall be set forth in the Supplement(s). Any future Supplements entered into between the parties shall reference and be governed by the terms of this Agreement. In the event of a conflict between the terms of this Agreement and a Supplement, the terms of the Supplement shall prevail.

3. EQUIPMENT WARRANTY, USE AND MAINTENANCE.

3.1. If applicable, Cincinnati Bell will maintain the equipment used to provide service under the applicable Supplements, in good working order during the term specified on the Services Agreement sheet, except CPE provided as part of any Ethernet service, subject to the exclusions set forth under Section four (4) entitled Warranty Exclusions. Customer will permit Cincinnati Bell access to equipment on Customer's premises used to provide service hereunder and Cincinnati Bell will comply with the Customer's security and safety regulations at Customer's site. Repair parts or replacement parts may be new, remanufactured or refurbished at the discretion of Cincinnati Bell. Customer will not make any modifications to the equipment used to provide service hereunder without the written permission of Cincinnati Bell and will pay the cost of any repairs necessitated by unauthorized work.

4. WARRANTY EXCLUSIONS.

4.1. The warranties provided under Section three (3) do not cover services required to repair damages, malfunctions or failures caused by: (a) Customer's failure to follow Cincinnati Bell's written operation or maintenance instructions provided to Customer; (b) Customer's unauthorized repair, modifications or relocation of equipment used to provide services hereunder, or attachment to such equipment of non-Cincinnati Bell equipment; and (c) abuse, misuse or negligent acts. Cincinnati Bell may perform services in such instances on a time and materials or contract basis.

4.2. Cincinnati Bell will not be liable to Customer or third parties for any claims, loss or expense of any kind or nature caused directly or indirectly by: (i) interruption or loss of use or loss of business; or (ii) any consequential, indirect, special or incidental damages suffered by Customer or third parties whatsoever.

4.3. Except as specified herein and any supplements, Cincinnati Bell, its subcontractors and suppliers (except as expressed in writing by them) make no warranties, express or implied, and specifically disclaim any warranty or merchantability of fitness for a particular purpose.

5. TITLE OR RISK OF LOSS OF EQUIPMENT.

5.1. For equipment sold to Customer and installed by Cincinnati Bell, title shall pass to Customer on the In-Service Date. Risk of loss shall pass at the time of delivery.

5.2. For all other equipment used in the provision of services under any of the Supplements, title shall remain solely with Cincinnati Bell, whether or not attached to or embedded in realty, unless otherwise agreed to in writing by the parties. Cincinnati Bell will bear the risk of loss or damage to the equipment used in the provision of service, except that Customer will be liable to Cincinnati Bell for the cost of repair or replacement of equipment lost or damaged as a result of Customer's negligence, intentional acts, unauthorized installation or maintenance or other causes within the control of Customer, its employees, agents or subcontractors.

6. GOVERNING LAW.

6.1. This Agreement shall be deemed to be a contract made under the laws of the State of Ohio, and the internal laws of such state shall govern the construction, interpretation and performance of this Agreement, without reference to conflicts of law provisions. Any legal action arising under this Agreement must be filed (and thereafter maintained) in a state or federal court located in Hamilton County, Ohio within two (2) years after the cause of action arises.

7. CONFIDENTIAL INFORMATION.

7.1. During the term of this Agreement and for two years thereafter, neither Party shall disclose any terms or pricing contained in this Agreement or any confidential information disclosed by the other Party. Confidential information shall remain the property of the disclosing Party and shall be labeled as either "Confidential" or "Proprietary".

8. RESOLUTION OF DISPUTES.

8.1. The Parties will attempt in good faith to resolve any controversy or claim arising out of or relating to this Agreement promptly through discussions between themselves at the operational level. In the event a resolution cannot be reached at the operational level, the disputing Party shall give the other Party written notice of the dispute and such controversy or claim shall be negotiated between appointed counsel or senior executives of the Parties who have authority to settle the controversy. If the Parties fail to resolve such controversy or claim within thirty (30) days of the disputing Party's notice, either Party may seek mediation as agreed upon by the parties or litigation.

9. TERMS OF PAYMENT.

9.1. Invoices for Services are due and payable in U.S. dollars within thirty (30) days of invoice date ("Invoice Due Date"). Customer shall allow for up to three (3) days for payment processing within such thirty (30) day period. Payments not received by Invoice Due Date are considered past due. In addition to Cincinnati Bell undertaking any of the actions set forth in this Agreement, Cincinnati Bell may apply late payment fees or take any action in connection with any other right or remedy Cincinnati Bell may have under this Agreement in law or in equity. Late payment fees will: (i) be assessed on any past due balance; (ii) be calculated as 2% of the past due balance if the past due balance includes regulated products or the greater of \$10.95 or 2% of the past due balance if the past due balance does not include regulated products; and (iii), will be added to the past due balance and included in future billing cycles. Customer shall be in default if Customer fails to make payment as required and such failure remains uncured for five (5) calendar days after the Invoice Due Date. If Customer in good faith disputes any portion of any Cincinnati Bell invoice, Customer shall submit to Cincinnati Bell by the Invoice Due Date, full payment of the undisputed portion of any Cincinnati Bell invoice and written documentation identifying and substantiating the disputed amount. If Customer does not report a dispute within sixty (60) days following the date on the applicable invoice, Customer shall have waived its right to dispute that invoice. Cincinnati Bell and Customer agree to use their respective best efforts to resolve any dispute within thirty (30) days after Cincinnati Bell receives written notice of the dispute from Customer. Any disputed amounts resolved in favor of Customer shall be credited to Customer's account on the next invoice following resolution of the dispute. Any disputed amounts determined to be payable to Cincinnati Bell shall be due within (10) days of resolution of the dispute.

9.2. Customer shall pay taxes levied upon any sale, transfer of ownership, installation, license or use of products or services, unless Customer provides a tax exemption certificate. Excluded are taxes on Cincinnati Bell's net income.

10. TERMINATION.

10.1. Notwithstanding the provisions regarding the Term and Termination Charges, of each Supplement, and in addition to the Parties' rights of termination specifically provided elsewhere in this Agreement, the following shall apply:

10.2. In the event Customer provides timely notice to Cincinnati Bell that it does not intend to renew an automatically renewing contract, Cincinnati Bell will continue to provide service to Customer after the expiration of the then current contract term on a month-to-month basis. The provision of such month-to-month service shall be subject to the terms and conditions and the month-to-month tariff / service agreement rates in effect at the time. Either Party may terminate the month-to-month service, without termination penalty, upon thirty (30) days advance written notice to the other Party.

10.3. In the event that one Party breaches any material obligation provided hereunder, excluding payment obligations, or in such Supplement (other than Customer's payment obligations), the other Party shall give the breaching Party written notice of the breach and request that the breach be cured ("Cure Notice"). If the breaching Party fails to cure the specified breach within thirty (30) days of receipt of the Cure Notice (or such other mutually agreed upon time), the other Party shall have the right to terminate the Supplement, effective upon five (5) days prior written notice to the breaching Party ("Termination Notice"). The right of Cincinnati Bell and the Customer to terminate in any such case shall be in addition to any other rights and remedies they may have hereunder or at law or in equity.

10.4. A Party may, at its option, terminate a Supplement effective immediately upon written notice upon the occurrence of an "Insolvency Event of Default" (as defined below) with respect to the other Party. The occurrence of any one or more of the following events shall constitute an "Insolvency Event of Default": the other Party admits in writing its inability to pay its debts generally or makes a general assignment for the benefit of creditors; any affirmative act of insolvency by the other Party or the filing by or against the other Party (which is not dismissed within ninety (90) days of any petition or action) under any bankruptcy, reorganization, insolvency arrangement, liquidation, dissolution or moratorium law, or any other law or laws for the relief of, or relating to, debtors; or the subjection of a material part of the other Party's property to any levy, seizure, assignment or sale for or by any creditor, third party or governmental agency.

10.5. If Customer cancels, in whole or in part, any requested addition, rearrangement, relocation or other modification to Services prior to completion thereof, Customer will reimburse Cincinnati Bell for the actual expenses incurred by Cincinnati Bell in connection with such modification prior to Cincinnati Bell's receipt of notice of cancellation; provided, however, the amount of such reimbursement will not exceed the service, construction, installation, termination and other charges for which Customer would have otherwise been responsible.

10.6. Customer shall have the right to terminate any Supplement for convenience at any time upon thirty (30) days prior written notice to Cincinnati Bell. The termination charge will be considered to be liquidated damages and will be Cincinnati Bell's sole remedy against Customer for early termination, except for outstanding charges. The termination liability language contained within the applicable Supplement is not intended to indicate that the Commissions have approved or sanctioned the specific termination charges contained herein. Signatories to the Agreement shall be free to pursue whatever legal remedies they may have should a dispute arise.

10.7. One or more Supplements may be terminated by the Parties without causing a termination of this Agreement or other Supplements.

11. INDEMNIFICATION.

Removed per Customer request

12. RESPONSIBILITIES OF EACH PARTY.

12.1. Each Party has and hereby retains the right to exercise full control of and supervision over its own performance of its obligations under this Agreement and retains full control over the employment, direction, compensation and discharge of their respective employees assisting in the performance of such obligations. Each Party will be solely responsible for all matters relating to payment of such employees, including compliance with social security taxes, withholding taxes and all other regulations governing such matters. Except as otherwise provided in this Agreement, each Party will be responsible for its own acts and those of its employees, agents, and contractors during the performance of such Party's obligations hereunder.

13. LIMITATIONS OF LIABILITY.

13.1. Cincinnati Bell's liability arising out of the provision of: (i) Services; (ii) delays in the restoration of Services; or (iii) arising out of mistakes, accidents, omissions, interruptions, errors or defects in transmission, or delays caused by judicial or regulatory authorities, shall be subject to the limitations set forth below and in the applicable Tariff. In no event shall Cincinnati Bell be liable to customer, customer's own customers, or any other third party with respect to the subject matter of this agreement under any contract, warranty, negligence, strict liability, or other theory for any type of indirect, consequential, incidental, reliance, special, or punitive damages, or for any lost profits, lost revenues, or lost savings of any kind, arising out of or relating to this agreement whether or not Cincinnati Bell or Customer was advised of the possibility of such damages and whether or not such damages were foreseeable. For purposes of this section, "Cincinnati Bell" is deemed to include Cincinnati Bell's parent company, and its respective affiliates and subsidiaries, and the directors, officers, employees, agents, representatives, subcontractors and suppliers of each of them.

13.2. The Parties hereto agree that the termination liabilities and the limitations on liability contained in this Agreement are fair and reasonable adjustments to the uncertain and difficult to ascertain damages which might arise under this Agreement and are intended to be reasonable allocations by the Parties of the business risks inherent in this Agreement.

14. SECURITY AND ACCESS.

14.1. Employees and agents of Cincinnati Bell and its subsidiaries, while on the premises of Customer, will comply with all reasonable rules, regulations and security requirements of Customer.

15. WORK ON CUSTOMER'S PREMISES.

15.1. In performance of its obligations hereunder, Cincinnati Bell shall comply with all applicable laws and will indemnify and hold Customer harmless from and against any claims, demands, suits, losses, damages, costs and expenses arising out of Cincinnati Bell's noncompliance with any such laws. If Cincinnati Bell's work related to this Agreement involves operations by Cincinnati Bell on the premises of Customer, Cincinnati Bell shall take reasonable precautions necessary to prevent the occurrence of any injury to person or property during the progress of such work. Except to the extent an injury to person or property is the result of Customer's negligence or willful misconduct, Cincinnati Bell shall defend, indemnify and hold harmless Customer against any claims, demands, suits, losses, damages, costs and expenses which are directly and proximately caused by negligent or willful conduct of Cincinnati Bell's employees, agents or subcontractors.

16. CUSTOMER OBLIGATIONS.

16.1. Prior to requesting repair service from Cincinnati Bell, Customer will use its best efforts, including but not limited to performing reasonable diagnostic tests, to verify whether any trouble with the Service is a result of the Customer's equipment or facilities. Customer shall be responsible for any such trouble resulting from the Customer's equipment or facilities. Customer will cooperate with any joint testing of the Service reasonably requested by Cincinnati Bell.

17. SYSTEM MAINTENANCE.

17.1. In the event Cincinnati Bell determines that it is necessary to interrupt Services or that there is a potential for Services to be interrupted for the performance of system maintenance, Cincinnati Bell will use good faith efforts to notify Customer prior to the performance of such maintenance and will schedule such maintenance during non-peak hours (midnight to 6:00 am. local time). In no event shall interruption for system maintenance constitute a failure of performance by Cincinnati Bell.

18. SUBCONTRACTING.

18.1. Cincinnati Bell may subcontract work to be performed under this Agreement, but shall retain responsibility for the work.

19. CHANGES IN LAWS.

19.1. This Agreement is predicated upon current state and federal laws and regulations. If new laws or regulations or new applications of current law and regulations affect this Agreement, either Party may request on thirty (30) days' written notice that one or more provisions be renegotiated consistent with the changed circumstances.

20. FORCE MAJEURE.

20.1. No Party shall be held liable for any delay or failure in performance of any part of this Agreement, including any Supplement, caused by a force majeure condition, including fires, pandemics, embargoes, explosions, power blackouts, earthquakes, volcanic action, floods, wars, water, the elements, labor disputes (such as a work stoppage), civil disturbances, government requirements, civil or military authorities, acts of God or a public enemy, inability to secure raw materials, inability to secure product of manufacturers or outside vendors, inability to obtain transportation facilities, acts or omissions of transportation common carriers, or other causes beyond its reasonable control whether or not similar to the foregoing conditions. If any force majeure condition occurs, the Party whose performance fails or is delayed because of such force majeure condition ("Delayed Party") shall promptly give written notice thereof to the other Party. The Delayed Party shall use all best efforts to avoid or mitigate performance delays despite a force majeure condition, and shall restore performance as soon as the force majeure condition is removed.

21. GOOD FAITH PERFORMANCE.

21.1. Each Party shall act in good faith in its performance under this Agreement and, in each case in which a Party's consent or agreement is required or requested hereunder, such Party shall not unreasonably withhold or delay such consent or agreement, as the case may be.

22. NO LICENSE.

22.1. Except as expressly provided in this Agreement or a Supplement, no license under patents, copyrights, trademarks, service marks, trade names or other indicia of origins, or any other intellectual property right (other than the limited license to use consistent with the terms, conditions and restrictions of this Agreement) is granted by either Party or shall be implied or arise by estoppel with respect to any transactions contemplated under this Agreement.

23. AMENDMENTS; WAIVERS.

23.1. Except as otherwise provided in this Agreement, no amendment or waiver of any provision of this Agreement, and no consent to any default under this Agreement, shall be effective unless the same shall be in writing and signed by an authorized official of the Party against whom such amendment, waiver or consent is claimed. In addition, no course of dealing or failure of any Party to strictly enforce any term, right or condition of this Agreement shall be construed as a waiver of such term, right or condition.

24. NOTICES.

24.1. All notices, demands, requests, elections, or other communications provided under this Agreement or which may be given by one Party to the other Party under this Agreement and to the extent a notice relates to an alleged breach, termination, or other claim under a Supplement, such notice shall be made in writing (unless specifically provided otherwise herein) and unless otherwise specifically required by this Agreement to be delivered to another representative or point of contact, shall be (a) delivered personally, (b) delivered by express delivery service, (c) mailed, first class, certified mail postage prepaid, return receipt requested or (d) delivered by telecopy and shall be deemed effective upon receipt; provided that a confirmation copy is sent by the method described in (a), (b) or (c) of this Section. Notices shall be addressed to the parties at the addresses set forth on the Services Agreement sheet.

24.2. Changes in notice designation shall be made in writing and shall be deemed effective upon receipt. Notices will be deemed given as of the earlier of (i) the date of actual receipt, (ii) the next business day when notice is sent via express mail or personal delivery, (iii) four (4) business days after mailing in the case of first class, certified U.S. mail or (iv) on the date set forth on the confirmation in the case of telecopy.

25. NO RIGHTS TO THIRD PARTIES.

25.1. This Agreement shall not be deemed to provide third parties with any remedy, claim, right of action or other right.

26. SEVERABILITY.

26.1. If any term, condition, or provision of this Agreement shall be invalid or unenforceable for any reason, such invalidity or unenforceability shall not invalidate or render unenforceable the remainder of this Agreement; and, unless such construction would be unreasonable, this Agreement shall be construed as if not containing the invalid or unenforceable provision or provisions and the rights and obligations of each Party shall be construed and enforced accordingly. If necessary to affect the intent of the Parties, the Parties shall negotiate in good faith to amend this Agreement to replace the unenforceable language with enforceable language that reflects such intent as closely as possible.

27. ASSIGNMENT.

27.1. Customer will not resell or permit any third party to use any of the services provided by Cincinnati Bell hereunder. Neither Customer nor Cincinnati Bell may assign this Agreement without the prior written consent of the other Party, which shall not be unreasonably withheld or delayed. Cincinnati Bell shall not be required to obtain consent in the case of a sale of all or substantially all the assets of Cincinnati Bell or an assignment to an entity directly or indirectly owning or controlling, owned or controlled by, or under common control with the assigning Party. Notwithstanding the foregoing, Cincinnati Bell shall retain the right to terminate this Agreement without further obligation or liability to Customer, its successors or assigns, if, in its sole and exclusive judgment any assignment or purported assignment by Customer is to be made to a competitor of Cincinnati Bell.

28. ENTIRE AGREEMENT; CONTINUING OBLIGATIONS.

28.1. The Agreement, which includes the Services Agreement, Terms & Conditions and Supplements, constitutes the entire Agreement between the Parties concerning the subject matter hereof. All prior agreements, representations, statements, negotiations, understandings, proposals, and undertakings, oral or written, with respect to the subject matter thereof are superseded and replaced by the provisions of this Agreement.

28.2. Irrespective of any provision contained in this Agreement or in any Supplement to the contrary, Articles 6 through 9 and Articles 11 through 30 of this Agreement shall take precedence over, supersede and control any conflicting provision (or the absence of a provision) heretofore or hereinafter executed by the Parties unless such Article, including any subsection thereof, is expressly identified as the subject of an amendment that is in writing and agreed upon by a representative of each Party having authority to agree to such amendment.

28.3. Any liability or obligation of any Party to the other Party for acts or omissions prior to the cancellation or termination of this Agreement, any obligation of any Party to make payments, any obligation of any Party under the provisions of Article 7 hereof regarding Confidential Information, Article 8 hereof regarding resolution of disputes, Articles 11 and 15 hereof regarding indemnification, and Article 13 regarding limitations on liability, and any provisions that, by their terms, are contemplated to survive (or be performed after) termination of this Agreement, shall, in each case, survive cancellation or termination of this Agreement.

28.4. The rights and obligations under this Agreement shall survive any merger or sale of either Party and shall be binding upon the successors and permitted assigns of each Party.

28.5. Under federal law, Customer has a right, and Cincinnati Bell has a duty, to protect the confidentiality of information regarding the telecommunications services Customer buys from Cincinnati Bell, including the amount, type, and destination of Customer's service usage; the way Cincinnati Bell provides services to Customer; and Customer's calling and billing records. Together, this confidential information is described as Customer Proprietary Network Information ("CPNI"). Customer hereby consents to Cincinnati Bell sharing its CPNI with Cincinnati Bell affiliates, subsidiaries and any other current or future direct or indirect subsidiaries of the Cincinnati Bell parent company as well as Cincinnati Bell agents and authorized sales representatives, to develop or bring to new products or services to Customer's attention. This consent survives the termination of Customer's service and is valid until Customer affirmatively revokes or limits such consent.

29. REGULATORY APPROVAL; TARIFFS.

29.1. This Agreement is subject to applicable regulatory requirements. In the event of any conflict between the terms of this Agreement and applicable regulatory requirements, such regulatory requirements will take precedence and be controlling. The obligations of Cincinnati Bell and Customer under this Agreement may be contingent upon approval of this Agreement by applicable regulatory agencies, including the Public Utilities Commission of Ohio and Public Services Commission of Kentucky. The regulations and rates specified herein are in addition to applicable regulations and rates set forth in Cincinnati Bell's tariffs on file with regulatory agencies.

30. EXECUTED IN COUNTERPARTS.

30.1. This Agreement may be executed in any number of counterparts, each of which shall be an original, but such counterparts shall together constitute but one and the same instrument.

31. HEADINGS.

31.1. The titles and headings of Articles and Sections of this Agreement have been inserted for convenience of reference only and are not to be considered a part hereof and shall in no way define, modify, or restrict the meaning or interpretation of the terms or provisions of this Agreement.

Resolution

Number 19-1068

Adopted Date August 20, 2019

AUTHORIZE THE WARREN COUNTY TELECOMMUNICATIONS DEPARTMENT TO INITIATE CONTRACT NEGOTIATIONS FOR INTERNET SERVICE BANDWIDTH AND BGP UPGRADE AT 500 JUSTICE DRIVE AND LYTLE

WHEREAS, the Board of County Commissioners (the "Board") on July 09, 2019 by Resolution Number 19-0859, authorized a request for proposals for an Internet Service Bandwidth and BGP upgrade; and

WHEREAS, after advertising the request for proposals for 30 days, the Warren County Telecommunications Department received and reviewed proposals from several companies; and

WHEREAS, the Warren County Telecommunications Department thoroughly reviewed each proposal, researched and investigated the various products and evaluated and ranked the proposals based on criteria and qualifications in the published Request for Proposals; and

WHEREAS, in accordance with Revised Code Section 307.862, and the procedures set forth in the published request for proposals, Warren County Telecommunications has ranked Level 3/Century Link for Internet Service Bandwidth and BGP upgrade at 500 Justice Drive and Crown Castle for Internet Service Bandwidth and BGP upgrade at Lytle as the Companies that are the most advantageous to Warren County Telecommunications to provide Internet Service Bandwidth and BGP upgrade; and

NOW THEREFORE BE IT RESOLVED, to authorize Warren County Telecommunications to initiate negotiations for an Internet Service Bandwidth & BGP upgrade with Level 3/Century Link at 500 Justice Drive and Crown Castle at Lytle. Should there be a failure to successfully negotiate a contract, then Warren County Telecommunications should report the same to the Board and shall enter into negotiations with the firm ranked next most advantageous.

Mr. Young moved for adoption of the foregoing resolution being seconded by Mr. Grossmann. Upon call of the roll, the following vote resulted:

Mrs. Jones – yea
Mr. Grossmann – yea
Mr. Young – yea

Resolution adopted this 20th day of August 2019.

BOARD OF COUNTY COMMISSIONERS



Tina Osborne, Clerk

cc: Telecom (file)
OMB Bid file

Resolution

Number 19-1069

Adopted Date August 20, 2019

APPROVE AGREEMENT AND ADDENDUM WITH FUTUREPROMISE AS A CHILD PLACEMENT AND RELATED SERVICE PROVIDER FOR THE WARREN COUNTY BOARD OF COUNTY COMMISSIONERS ON BEHALF OF WARREN COUNTY CHILDREN SERVICES

BE IT RESOLVED, to approve and authorize the Warren County Board of Commissioners to enter into the agreement and addendum with FuturePromise, on behalf of Warren County Children Services, for calendar year 2019, for the services of a child placement and related services provider. Copy of agreement attached hereto and made a part hereof.

Mr. Young moved for adoption of the foregoing resolution being seconded by Mr. Grossmann. Upon call of the roll, the following vote resulted:

Mrs. Jones – yea
Mr. Grossmann – yea
Mr. Young – yea

Resolution adopted this 20th day of August 2019.

BOARD OF COUNTY COMMISSIONERS


Tina Osborne, Clerk

jc/

cc: c/a—FuturePromise
Children Services (file)

AFFIDAVIT OF NON COLLUSION

STATE OF Ohio
COUNTY OF Hamilton

I, LINDONIA WUCHE, holding the title and position of EXECUTIVE DIRECTOR at the firm FUTURE PROMISE, affirm that I am authorized to speak on behalf of the company, board directors and owners in setting the price on the contract, bid or proposal. I understand that any misstatements in the following information will be treated as fraudulent concealment of true facts on the submission of the contract, bid or proposal.

I hereby swear and depose that the following statements are true and factual to the best of my knowledge:

The contract, bid or proposal is genuine and not made on the behalf of any other person, company or client, INCLUDING ANY MEMBER OF THE WARREN COUNTY BOARD OF COMMISSIONERS.

The price of the contract, bid or proposal was determined independent of outside consultation and was not influenced by other companies, clients or contractors, INCLUDING ANY MEMBER OF THE WARREN COUNTY BOARD OF COMMISSIONERS.

No companies, clients or contractors, INCLUDING ANY MEMBER OF THE WARREN COUNTY BOARD OF COMMISSIONERS have been solicited to propose a fake contract, bid or proposal for comparative purposes.

No companies, clients or contractors, INCLUDING ANY MEMBER OF THE WARREN COUNTY BOARD OF COMMISSIONERS have been solicited to refrain from bidding or to submit any form of noncompetitive bidding.

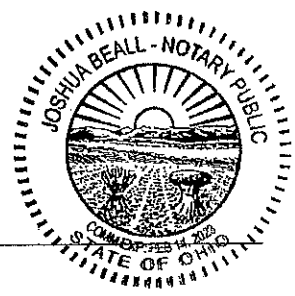
Relative to sealed bids, the price of the bid or proposal has not been disclosed to any client, company or contractor, INCLUDING ANY MEMBER OF THE WARREN COUNTY BOARD OF COMMISSIONERS, and will not be disclosed until the formal bid/proposal opening date.

[Signature]
AFFIANT

Subscribed and sworn to before me this 13th day of July 2019

[Signature]
(Notary Public),
Hamilton County.

My commission expires Feb 14 2023



Ohio Department of Job and Family Services

AGREEMENT FOR TITLE IV-E AGENCIES AND PROVIDERS FOR THE PROVISION OF CHILD PLACEMENT

This Agreement sets forth the terms and conditions between the parties for placement services for children who are in the care and custody of the Agency named below.

This Agreement is between Warren County Children Services, a Title IV-E Agency, hereinafter "Agency," whose address is:

Warren County Children Services
416 S East St
Lebanon, OH 45036

and FuturePromise, hereinafter "Provider," whose address is:

FuturePromise
1701 Kinney Ave
Cincinnati, OH 45207

Collectively the "Parties."

Table of Contents

ARTICLE I.	SCOPE OF PLACEMENT SERVICES	3
Section 1.01	FOR AGREEMENTS COMPETITIVELY PROCURED	3
Section 1.02	FOR AGREEMENTS NOT COMPETITIVELY PROCURED	3
Section 1.03	EXHIBITS	3
ARTICLE II.	TERM OF AGREEMENT	4
ARTICLE III.	ORDER OF PRECEDENCE	4
ARTICLE IV.	DEFINITIONS GOVERNING THIS AGREEMENT	4
ARTICLE V.	PROVIDER RESPONSIBILITIES	5
ARTICLE VI.	AGENCY RESPONSIBILITIES	6
ARTICLE VII.	INVOICING FOR PLACEMENT SERVICES	7
ARTICLE VIII.	REIMBURSEMENT FOR PLACEMENT SERVICES	7
ARTICLE IX.	TERMINATION; BREACH AND DEFAULT	8
ARTICLE X.	RECORDS RETENTION AND CONFIDENTIALITY	9
ARTICLE XI.	PROVIDER ASSURANCES AND CERTIFICATIONS	9
ARTICLE XII.	INDEPENDENT CONTRACTOR	10
ARTICLE XIII.	AUDITS AND OTHER FINANCIAL MATTERS	11
ARTICLE XIV.	GRIEVANCE /DISPUTE RESOLUTION PROCESS	11
ARTICLE XV.	AMENDMENTS	11
ARTICLE XVI.	NOTICE	12
ARTICLE XVII.	CONSTRUCTION	12
ARTICLE XVIII.	NO ASSURANCES	12
ARTICLE XIX.	CONFLICT OF INTEREST	12
ARTICLE XX.	INSURANCE	13
ARTICLE XXI.	INDEMNIFICATION & HOLD HARMLESS	14
ARTICLE XXII.	SCREENING AND SELECTION	14
ARTICLE XXIII.	PROHIBITION OF CORPORAL & DEGRADING PUNISHMENT	15
ARTICLE XXIV.	EXCLUDED PARTIES LIST	15
ARTICLE XXV.	PUBLIC RECORDS	15
ARTICLE XXVI.	CHILD SUPPORT ENFORCEMENT	15
ARTICLE XXVII.	DECLARATION OF PROPERTY TAX DELINQUENCY	16
ARTICLE XXVIII.	SUBCONTRACTING AND DELEGATION	16
ARTICLE XXIX.	PROPERTY OF AGENCY	16
ARTICLE XXX.	WAIVER	16
ARTICLE XXXI.	NO ADDITIONAL WAIVER IMPLIED	16
ARTICLE XXXII.	COUNTERPARTS	16
ARTICLE XXXIII.	APPLICABLE LAW AND VENUE	16
ADDENDA TO THIS AGREEMENT		18

RECITALS

WHEREAS, the Agency is responsible under Ohio Revised Code (ORC) Title 51, Chapter 5153 for the provision of protective services for dependent, neglected, and abused children; and,

WHEREAS, the Agency is authorized under ORC Title 51, Chapter 5153.16 to provide care and services which it deems to be in the best interest of any child who needs or is likely to need public care and services; and,

WHEREAS, the Provider is an organization duly organized and validly existing and is qualified to do business under the laws of the State of Ohio or in the state where the placement facility or foster home is located and has all requisite legal power and authority to execute this Agreement and to carry out its terms, conditions and provisions, and is licensed, certified or approved to provide placement and related services to children in accordance with Ohio law or the state where the placement facility or foster home is located.

NOW, THEREFORE, in consideration of the mutual promises and responsibilities set forth herein, the Agency and Provider agree as follows:

Article I. SCOPE OF PLACEMENT SERVICES

In addition to the services described in Exhibit I-Scope of Work, Provider agrees to provide and shall provide the placement and related services specified in each Individual Child Care Agreement (ICCA) for children in the care and custody of the Title IV-E Agency. The ICCA shall be consistent with current federal, state and local laws, rules and regulations applicable to the Provider's license or certified functions and services. If an Agreement and ICCA both exist, the Agreement supersedes.

Section 1.01 FOR CONTRACTS COMPETITIVELY PROCURED

Without limiting the services set forth herein, Provider will provide the Services pursuant to and consistent with the Requests for Proposals (RFP) and the Provider's Proposal submitted in response to the RFP, the Provider agrees to provide and shall provide the placement and related services described in Exhibit I-Scope of Work.

Section 1.02 FOR CONTRACTS NOT COMPETITIVELY PROCURED

The Provider agrees to provide and shall provide the placement and related services described in the Exhibit I-Scope of Work.

Section 1.03 EXHIBITS

The following exhibits are deemed to be a part of this Agreement as if fully set forth herein:

- A. Exhibit I – Scope of Work;
- B. Exhibit II – Request for Proposals (if applicable);
- C. Exhibit III – Provider's Response to the Request for Proposals (if applicable); and
- D. Exhibit IV – Schedule A Rate Information.

Article II. TERM OF AGREEMENT

This Agreement is in effect from **06/01/2019** through **03/31/2020**, unless this Agreement is suspended or terminated pursuant to Article IX prior to the termination date.

In addition to the initial term described above, this Agreement may be extended at the option of the Agency and upon written agreement of the Provider. Notice of Agency's intention to extend the Agreement shall be provided in writing to Provider no less than 90 calendar days before the expiration of any Agreement term then in effect. (If a previous Request for Proposal [RFP] allows, the Agreement may be extended for a period of time to ensure adequate completion of the Agency's competitive procurement process at the rates existing for the term then in effect.)

Article III. ORDER OF PRECEDENCE

This Agreement and all Exhibits are intended to supplement and complement each other and shall, where possible, be so interpreted. However, if any provision of this Agreement irreconcilably conflicts with an Exhibit, this Agreement takes precedence over the Exhibit(s).

In the event there is an inconsistency between the Exhibit(s), the inconsistency shall be resolved in the following order:

- A. Exhibit I – Scope of Work; then
- B. Exhibit II – Request for Proposals (if applicable); then
- C. Exhibit III – Provider's Proposals (if applicable); then
- D. Exhibit IV – Title IV-E Schedule A Rate Information.

Article IV. DEFINITIONS GOVERNING THIS AGREEMENT

The following definitions govern this Agreement:

- A. Agreement means this Agreement, addenda and exhibits thereto.
- B. Material Breach shall mean an act or omission that violates or contravenes an obligation required under the Agreement and which, by itself or together with one or more other breaches, has a negative effect on, or thwarts the purpose of the Agreement as stated herein. A Material Breach shall not include an act or omission, which has a trivial or negligible effect on the quality, quantity, or delivery of the goods and services to be provided under the Agreement.
- C. Child(ren) means any person under eighteen years of age or a mentally or physically handicapped person under twenty-one years of age in the Agency's custody and under the care of the Provider for the provision of placement services.
- D. All other definitions to be resolved through Federal Regulations, Ohio Administrative Code (OAC) 5101:2-1-01 and any related cross-references.

Article V. PROVIDER RESPONSIBILITIES

- A. Provider agrees to participate with Agency in the development and implementation of the Case Plan and ICCA including participation in case reviews and / or semi-annual administrative reviews, and the completion of reunification assessments for the children in placement with the Provider. Parties shall make best efforts to share information timely regarding participants and contact information involved with planning efforts related to children and families.
- B. Provider agrees to provide services agreed to in the Case Plan and ICCA (i.e., transportation of children for routine services, including, but not limited to, court hearings, medical appointments, school therapy, recreational activities, visitations/family visits) unless otherwise negotiated in writing as an attachment to this Agreement. Any disputes involving services or placement will be resolved through mutual-agreement and modification to the ICCA. Provider agrees the Agency is the final authority in the process. The cost of providing these services is to be included in the Agency approved per diem.
- C. Provider agrees to ensure that any and all persons who may act as alternative caregivers or who have contact with the children are suitable for interaction pursuant to all applicable federal, state and local laws and regulations.
- D. Provider agrees that all caregivers must be approved by the Agency.
- E. Provider agrees to submit a progress report as negotiated by the parties for each child. The progress report will be based on the agreed upon services to be delivered to the child and/or family and will include documentation of services provided to the child and/or discharge summary. If Monthly Progress Reports are not received within 90 calendar days following the month of service provision, payment may be withheld at the Agency's discretion.
 - 1. Monthly Progress Reports shall be submitted by the 20th of the month following the month of service.
 - 2. The Monthly Progress Report will include the following medical related information:
 - a. Service type (i.e. medical, dental, vision, etc.);
 - b. Date(s) of service;
 - c. Reason for visit (i.e. routine, injury, etc.);
 - d. Practitioner name, address and contact number;
 - e. Name of hospital, practice, urgent care, etc.;
 - f. Prescribed medications and dosages;
 - g. Date(s) medication(s) were prescribed or changed; and
 - h. Changes to medications.
- F. Placement changes, emergency or non-emergency, shall occur only with the approval of the Agency. The following information shall be provided to the Agency for all placement changes: Name, address and phone number of the new foster home or other out-of-home care setting, the license/home study of the new care provider within 24 hours, excluding weekends and holidays.
- G. Provider agrees to notify all Agencies who have children placed in the same caregiver's home/group home/CRC when any child residing in the placement is critically injured or dies in that location. Notification will be made to the Agencies' Child Abuse/Neglect Hotline number or assigned Caseworker immediately.
- H. Notification to the Agency of Emergency Critical Incidents shall occur ASAP but no later than one hour of the Incident becoming known. Notification will be made to the Agency via the Agency's Child Abuse/Neglect Hotline or

assigned Caseworker or by other established system. Critical incidents are those incidents defined in the Ohio Administrative Code that are applicable to the licensed or certified programs(ODJFS 5101:2-7-14, 5101:2-9-23 ODMHAS 5122-30-16, 5122-26-13, DODD 5123:2-17-02).

Emergency situations include but are not limited to the following:

1. Absent Without Leave (AWOL);
 2. Child Alleging Physical or Sexual Abuse/Neglect;
 3. Death of Child;
 4. Illicit drug/alcohol use, Abuse of medication or toxic substance;
 5. Sudden injury or illness requiring an unplanned medical treatment or visit to the hospital;
 6. Perpetrator of Delinquent/Criminal Act (Assault, Dangerous Behaviors, Homicidal Behaviors);
 7. School Expulsion/Suspension (formal action by school);
 8. Self-Injury (Suicidal Behaviors, Self-Harm Requiring external Medical Treatment, Hospital or ER);
 9. Victim of assault, neglect, physical or sexual abuse;
 10. The filing of any law enforcement report involving the child.
- I. The Provider also agrees to notify the Agency within Twenty-four (24) hours, of any non-emergency situations. Non-emergency situations include but are not limited to the following:
1. When physical restraint is used/applied; and
 2. Medication lapses or errors.
- Notification will be made to the Agency via the Agency's Child Abuse/Neglect Hotline/assigned Caseworker or by other established notification system.
- J. Documentation of the emergency and non-emergency incidents as identified in "H and I" above shall be provided to the Agency via email, fax or other established notification system within 24 hours excluding weekends and holidays.
- K. The Provider agrees to submit each child's assessment and treatment plans as completed but no later than the 30th day of placement. Provider further agrees to provide treatment planning that will include, but is not limited to, education on or off site, preparation for integration into community-based school or vocational/job skills training, community service activities, independent living skills if age 14 or older, monitoring and supporting community adjustment.
- L. The Provider agrees to participate in joint planning with the Agency regarding modification to case plan services. Provider agrees that while the Provider may have input into the development of the child's case plan services and the ICCA, any disputes involving services or placement will be resolved through mutual agreement and modification to the ICCA. Provider agrees the Agency is the final authority in the process.
- M. The Provider shall participate in a Placement Preservation meeting if requested by the Agency prior to issuing a notice of removal of a child. A placement Preservation meeting shall be held within seven (7) business days of said request. Unless otherwise mutually agreed upon a minimum of thirty (30) calendar days' notice shall be given if placement preservation is unable to be achieved. A Discharge Plan Summary shall be provided no later than fifteen (15) calendar days after the date of discharge in accordance with the applicable licensed or certified program. (OAC 5101:2-5-17, OAC 5122-30-22, OAC 5122-30-04, OAC 5123:2-3-05).
- N. The Provider shall work in cooperation and collaboration with the Agency to provide information for each child's Lifebook and will fully comply with the provision of OAC 5101:2-42-67 as applicable to private Providers. Provider's contribution to the Agency Lifebook for a child shall be for the episode of care with the Provider.
- O. The Provider agrees to provide Independent Living Services as set forth in accordance with OAC 5101:2-42-19 for all children age 14 and above.
- P. When applicable, due to the Provider being part of a managed care agreement as defined in OAC 5101:2-1-01, the Provider agrees to visit with the child face-to-face in the foster home, speak privately with the child and to meet with the caregiver at least monthly in accordance with rule OAC 5101:2-42-65 of the Ohio Administrative Code.
- Q. The Provider agrees to maintain its licenses and certifications from any source in good standing. The Provider agrees to report to Agency in writing any change in licensure or certification that negatively impacts such standing immediately if the negative action results in a temporary license, suspension of license or termination of license.
- R. Provider agrees that the reasonable and prudent parent standard training required by SEC. 471, [42 U.S.C. 671] of the Social Security Act and in accordance to OAC 5101:2-5-33, OAC 5101:2-9-02 or OAC 5101:2-9-03 has been

completed.

- S. The Provider shall notify Agency of any changes in its status, such as intent to merge with another business or to close no later than forty-five (45) business days prior to the occurrence.
- T. The Provider agrees that the Agency shall have access to foster parent home studies and re-certifications for foster parents caring for children in placement, subject to confidentiality considerations. The Provider shall submit to Agency a copy of the current foster home license at the time of placement and recertification. Provider also agrees to notify Agency within twenty-four (24) hours of any change in the status of the foster home license.
- U. When there is a rule violation of a caregiver, a copy of the corrective action plan, if applicable, must be submitted to the Agency when the investigation is complete.
- V. The Provider agrees to notify the Agency of scheduling no less than fourteen (14) calendar days prior to all formal meetings (i.e. FTMs, Treatment Team Meetings, IEPs, etc.).
- W. The Provider agrees to adhere to the following Medical/Medication guidelines:
 - 1. To provide over-the-counter medications and/or supplies as part of the per diem of care;
 - 2. To comply with the medical consent process as identified by Agency;
 - 3. Only the Agency can give permission for the administering or change (addition or elimination) of psychotropic medication and its ongoing management; and
 - 4. Provide an initial placement medical screening within 72 hours of child's placement into a placement resource under the Provider's operation and/or oversight.
- X. To arrange for required health care/medical examinations within time frames required by OAC 5101:2-42-66.1 and provide reports from the health care providers to the agency within 30 days of occurrence if the appropriate releases of information have been obtained by the Provider.
- Y. The Network Provider agrees to notify the Agency if placement resource is currently under investigation for license violations or misconduct toward children or other third-party investigation.
- Z. The Provider will immediately notify the Agency:
 - 1. If the Provider is out of compliance with any licensing authority rules or the placement resource is under investigation for license violations or misconduct toward children. Immediately is defined as within one hour of knowledge of the non-compliance issue.
 - 2. Child Abuse/Neglect Hotline or assigned Caseworker of any allegations of abuse or neglect made against the Caregiver within one hour of gaining knowledge of the allegation.
 - 3. Of any corrective action and the result of the correction action plan. The Provider will submit a comprehensive written report to the agency within sixty (60) days of the rules violation.
 - 4. Within twenty-four (24) hours any time there is an event which would impact the placement resource license.

Article VI. AGENCY RESPONSIBILITIES

- A. Agency certifies that it will comply with the Multiethnic Placement Act, 108 STAT. 3518, as amended by Section 1808 of the Small Business Jobs Protection Act of 1996, 110 STAT. 1755, which prohibits any Agency from denying any person the opportunity to become an adoptive or foster parent on the basis of race, color, national origin, or delaying or denying the placement of a child for adoption or into foster care on the basis of race, color, or national origin of the adoptive or foster parent or of the child involved.
- B. The Agency shall provide to the Provider within thirty (30) calendar days of placement or within a reasonable time thereafter as agreed to by the parties, a copy of each child's social history, medical history, and Medicaid card once obtained by the Agency for new cases, or at time of placement for existing cases. Agency shall make best efforts to share information timely regarding participants and contact information involved with planning efforts related to children and families.
- C. Agency agrees to participate in the development of the treatment plan of each child placed with the Provider. The Agency acknowledges that clinical treatment decisions must be recommended by licensed clinical professionals. Agency and Provider acknowledge that disagreement with a treatment decision may be taken through the dispute resolution process contained in Article XIV of this Agreement.
- D. Agency agrees to visit with the child in accordance with rule OAC 5101:2-42-65 of the Ohio Administrative Code.
- E. Agency agrees to participate in periodic meetings with each child's treatment team for case treatment plan development, review, and revision. The Agency agrees to participate in the development of the treatment plan of each child placed with the Provider by the Agency.

- F. Agency certifies that it will comply with Every Student Succeeds Act (34 CFR part 200) and will work with local school districts in developing individualized plans to address the transportation needed for a child to remain in the school of origin. Agency agrees to arrange for the transfer of each child's school records to the child's new school upon placement but not later than ten (10) business days. The Agency agrees to work with the Provider for the timely enrollment of the child in the receiving school district. The Agency has the final responsibility to obtain the child's school records and to enroll the child in the receiving school district.
- G. The Agency shall provide an opportunity for the Provider to give input in the development, substantive amendment or modification of case plans. The Agency agrees to notify the Provider of scheduling no less than seven (7) calendar days prior to of all formal meetings (e.g. SARs, court hearings, family team conferences, etc.).
- H. The Agency shall participate in a Placement Preservation meeting if requested by the Provider prior to issuing a notice of removal of a child. The Agency shall provide a minimum of thirty (30) calendar days' notice for planned removals, to the Provider for each child who is being terminated from placement with the Provider, unless so ordered by a court of competent jurisdiction.
- I. Agency agrees to provide the Provider with an emergency contact on a twenty-four (24) hour, seven (7) day per week basis.
- J. The Agency represents:
 - 1. It has adequate funds to meet its obligations under this Agreement; subject to the availability of funds as referenced in Article VIII (I);
 - 2. It intends to maintain this Agreement for the full period set forth herein and has no reason to believe that it will not have sufficient funds to enable it to make all payments due hereunder during such period; and
 - 3. It will make its best effort to obtain the appropriation of any necessary funds during the term of this Agreement.
- K. The Agency will provide information about the child being referred for placement in accordance with OAC 5101:2-42-90. Prior to a child's placement in alternative care or respite, OAC 5101:2-42-90 (D) requires the Agency to share with care givers information that could impact the health, safety, or well-being of the child or others in the home.

Article VII. INVOICING FOR PLACEMENT SERVICES

- A. The Provider agrees to submit a monthly invoice following the end of the month in which services were provided. The invoice shall be for services delivered in accordance with Article I of this Agreement and shall include:
 - 1. Provider's name, address, telephone number, fax number, federal tax identification number, Title IV-E Provider number, if applicable and Medicaid Provider number, if applicable.
 - 2. Billing date and the billing period.
 - 3. Name of child, date of birth of child, and the child's Statewide Automated Child Welfare Information System (SACWIS) person I.D. number.
 - 4. Admission date and discharge date, if available.
 - 5. Agreed upon per diem for maintenance and the agreed per diem administration; and
 - 6. Invoicing procedures may also include the per diems associated with the following if applicable and agreeable to the Agency and Provider:
 - a. Case Management; allowable administration cost.
 - b. Transportation, allowable maintenance cost.
 - c. Transportation; allowable administration cost.
 - d. Other Direct Services; allowable maintenance cost.
 - e. Behavioral health care; non-reimbursable cost.
 - f. Other costs - (any other cost the Title IV-E Agency has agreed to participate in); non-allowable/non-reimbursable cost.
- B. Provider warrants and represents claims made for payment for services provided are for actual services rendered and do not duplicate claims made by Provider to other sources of public funds for the same service.

Article VIII. REIMBURSEMENT FOR PLACEMENT SERVICES

- A. The maximum amount payable pursuant to this contract is **\$100,000.00**.
- B. In accordance with Schedule A of this Agreement, the per diem for maintenance and the per diem for

administration will be paid for each day the child was in placement. The first day of placement will be paid regardless of the time the child was placed. The last day of placement will not be paid regardless of the time the child left the placement.

- C. In accordance with Schedule A of this Agreement and in addition to Maintenance and Administration, the Agency may agree to pay a per diem for Case Management, Other Direct Services, Transportation Administration, Transportation Maintenance, Behavioral Health Care and Other. All other services and/or fees to be paid for shall be contained in the Addendum of this Agreement.
- D. To the extent that the Provider maintains a foster care network, the agreed upon per diem for maintenance shall be the amount paid directly to the foster parent. Maintenance includes the provision of food, clothing, shelter, daily supervision, graduation expenses, a child's personal incidentals, and liability insurance with respect to the child, reasonable cost of travel to the child's home for visitation and reasonable cost of travel for the child to remain in the school the child was enrolled in at the time of placement. Payment for private Agency staff transporting a child to a home visit or keeping the child in their home school will be paid in accordance with Schedule A (Transportation Maintenance) of this Agreement.
- E. If the plan as determined by the Agency is to return the child to placement with the Provider, the Agency may agree to pay for the days that a child is temporarily absent from the direct care of the Provider, as agreed to by the parties in writing.
- F. The service provider is required to utilize Medicaid-approved healthcare providers in the appropriate managed care network for the provision of mental health, dental and/or medical services (hereafter referred to collectively as "medical services") to children in the custody of Agency. The Service Provider will report applicable Medicaid/insurance information to the healthcare providers and instruct healthcare providers to seek payment from Medicaid or any other available third-party payer for medical services rendered to children in agency custody. Agency will not pay for the provision of any medical services to children in agency custody unless the agency Executive Director or authorized designee has provided specific prior written authorization for such medical services and associated costs.
- G. The Agency agrees to pay the Provider for all services agreed to on Schedule A and in the Addendum to this Agreement, where applicable, that have been provided and documented in the child's case file. Agency shall make best efforts to make payment of undisputed charges within thirty (30) business days of receipt.
- H. In the event of a disagreement regarding payment, Agency shall withhold payment only for that portion of the placement with which it disagrees. Agency will use best efforts to notify the Provider of any invoice discrepancies. Agency and Provider will make every effort to resolve payment discrepancies within 60 calendar days. Payment discrepancies brought to the Agency after 60 days will be reviewed on a case by case basis.
- I. This Agreement is conditioned upon the availability of federal, state, or local funds appropriated or allocated for payment for services provided under the terms and conditions of this Agreement. By sole determination of the Agency, if funds are not sufficiently allocated or available for the provision of the services performed by the Provider hereunder, the Agency reserves the right to exercise one of the following alternatives:
 1. Reduce the utilization of the services provided under this Agreement, without change to the terms and conditions of the Agreement; or
 2. Issue a notice of intent to terminate the Agreement.

The Agency will notify the Provider at the earliest possible time of such decision. No penalty shall accrue to the Agency in the event either of these provisions is exercised. The Agency shall not be obligated or liable for any future payments due or for any damages as a result of termination under this section.

Any denial of payment for service(s) rendered may be appealed in writing and will be part of the dispute resolution process contained in Article XIV.

Article IX. TERMINATION; BREACH AND DEFAULT

- A. This Agreement may be terminated for convenience prior to the expiration of the term then in effect by either the Agency or the Provider upon written notification given no less than sixty (60) calendar days in advance by certified mail, return receipt requested, to the last known address of the terminated party shown hereinabove or at such other address as may hereinafter be specified in writing.
- B. If Provider fails to provide the Services as provided in this Agreement for any reason other than Force Majeure, or if Provider otherwise Materially Breaches this Agreement, Agency may consider Provider in default. Agency agrees to give Provider thirty (30) days written notice specifying the nature of the default and its intention to terminate. Provider shall have seven (7) calendar days from receipt of such notice to provide a written plan of action to Agency to cure such default. Agency is required to approve or disapprove such plan within five (5)

calendar days of receipt. In the event Provider fails to submit such plan or Agency disapproves such plan, Agency has the option to immediately terminate this Agreement upon written notice to Provider. If Provider fails to cure the default in accordance with an approved plan, then Agency may terminate this Agreement at the end of the thirty (30) day notice period.

- C. Upon the effective date of the termination, the Provider agrees that it shall cease work on the terminated activities under this Agreement, take all necessary or appropriate steps to limit disbursements and minimize costs, and furnish a report as of the date of discharge of the last child describing the status of all work under this Agreement, including without limitation, results accomplished, conclusions resulting therefrom, and such other matters as the Agency may require. The Agency agrees to remove all children in placement immediately with the Provider, consistent with the effective termination date. In all instances of termination, the Provider and Agency agree that they shall work in the best interests of children placed with the Provider to secure alternative placements for all children affected by the termination.
- D. In the event of termination, the Provider shall be entitled to reimbursement, upon submission of an invoice, for the agreed upon per diem incurred prior to the effective termination date. The reimbursement will be calculated by the Agency based on the per diem set forth in Article VIII. The Agency shall receive credit for reimbursement already made when determining the amount owed to the Provider. The Agency is not liable for costs incurred by the Provider after the effective termination date of the discharge of the last child.
- E. Notwithstanding the above, Agency may immediately terminate this Agreement upon delivery of a written notice of termination to the Provider under the following circumstances:
 - 1. Improper or inappropriate activities;
 - 2. Loss of required licenses;
 - 3. Actions, inactions or behaviors that may result in harm, injury or neglect of a child;
 - 4. Unethical business practices or procedures; and
 - 5. Any other event that Agency deems harmful to the well-being of a child; or
 - 6. Loss of funding as set forth in Article VIII.
- F. If the Agreement is terminated by Agency due to breach or default of any of the provisions, obligations, or duties embodied contained therein by the Provider, Agency may exercise any administrative, agreement, equitable, or legal remedies available, without limitation. Any extension of the time periods set forth above shall not be construed as a waiver of any rights or remedies the Agency may have under this Agreement.
- G. In the event of termination under this ARTICLE, both the Provider and the placing Agency shall make good faith efforts to minimize adverse effect on children resulting from the termination of the Agreement.

Article X. RECORDS RETENTION ,CONFIDENTIALITY AND DATA SECURITY REQUIREMENTS

- A. The Provider agrees that all records, documents, writings or other information, including, but not limited to, financial records, census records, client records and documentation of legal compliance with Ohio Administrative Code rules, produced by the Provider under this Agreement, and all records, documents, writings or other information, including but not limited to financial, census and client used by the Provider in the performance of this Agreement are treated according to the following terms:
 - 1. All records relating to costs, work performed and supporting documentation for invoices submitted to the Agency by the Provider along with copies of all Deliverables, as defined in Article XXIX, submitted to the Agency pursuant to this Agreement will be retained for a minimum of three (3) years after reimbursement for services rendered under this Agreement.
 - 2. If an audit, litigation, or other action is initiated during the time period of the Agreement, the Provider shall retain such records until the action is concluded and all issues resolved or three (3) years have expired, whichever is later.
 - 3. All records referred to in Section A 1) of this Article shall be available for inspection and audit by the Agency or other relevant agents of the State of Ohio (including, but not limited to, the County Prosecutor, the Ohio Department of Job and Family Services (ODJFS), the Auditor of the State of Ohio, the Inspector General of Ohio, or any duly authorized law enforcement officials), and the United States Department of Health and Human Services within a reasonable period of time.
- B. The Provider agrees to keep all financial records in a manner consistent with Generally Accepted Accounting Principles.
- C. The Provider agrees to comply with all federal and state laws applicable to the Agency and the confidentiality of children and families. Provider understands access to the identities of any Agency's child and families shall only be

as necessary for the purpose of performing its responsibilities under this Agreement. No identifying information on child(ren) served will be released for research or other publication without the express written consent of the Agency. Provider agrees that the use or disclosure of information concerning the child for any purpose not directly related to the administration of this Agreement is prohibited. Provider shall ensure all the children's and families' documentation is protected and maintained in a secure and safe manner.

- D. The Provider agrees to comply with all applicable state and federal laws related to the confidentiality and transmission of medical records, including, but not limited to the Health Insurance Portability and Accountability Act of 1996 (HIPAA).
- E. Although information about, and generated under, this Agreement may fall within the public domain, the Provider shall not release information about, or related to, this Agreement to the general public or media verbally, in writing, or by any electronic means without prior approval from the Agency, unless the Provider is required to release requested information by law. Agency reserves the right to announce to the general public and media: award of the Agreement, Agreement terms and conditions, scope of work under the Agreement, Deliverables, as defined in Article XXIX, and results obtained under the Agreement. Except where Agency approval has been granted in advance, the Provider shall not seek to publicize and will not respond to unsolicited media queries requesting: announcement of Agreement award, Agreement terms and conditions, Agreement scope of work, government-furnished documents the Agency may provide to the Provider to fulfill the Agreement scope of work, Deliverables required under the Agreement, results obtained under the Agreement, and impact of Agreement activities.
- F. If contacted by the media about this Agreement, the Provider agrees to notify the Agency in lieu of responding immediately to media queries. Nothing in this section is meant to restrict the Provider from using Agreement information and results to market to specific business prospects.
- G. Client data must be protected and maintained in a secure and safe manner whether located in Provider's facilities, stored in the Cloud, or used on mobile devices outside Provider's facility. Security of Provider's network, data storage, and mobile devices must conform to generally recognized industry standards and best practices. Maintenance of a secure processing environment includes, but is not limited to, network firewall provisioning, intrusion detection, antivirus protection, regular third-party vulnerability assessments, and the timely application of patches, fixes and updates to operating systems and applications.
- H. Provider agrees that it has implemented and shall maintain during the term of this Agreement the highest standard of administrative, technical, and physical safeguards and controls to:
 - 1. Ensure the security and confidentiality of data;
 - 2. Protect against any anticipated security threats or hazards to the security or integrity of data; and
 - 3. Protect against unauthorized access to or use of data. Such measures shall include at a minimum:
 - a. Access controls on information systems, including controls to authenticate and permit access to data only to authorized individuals and controls to prevent Provider employees from providing data to unauthorized individuals who may seek to obtain this information (whether through fraudulent means or otherwise);
 - b. Firewall protection;
 - c. Encryption of electronic data while in transit from Provider networks to external networks;
 - d. Measures to store in a secure fashion all data which shall include multiple levels of authentication;
 - e. Measures to ensure that data shall not be altered or corrupted without the prior written consent of the Agency;
 - f. Measures to protect against destruction, loss or damage of data due to potential environmental hazards, such as fire and water damage.
- I. Immediately upon discovery of a confirmed or suspected breach involving data, Provider will notify Agency no later than twenty-four (24) hours after Provider knows or reasonably suspects a breach has or may have occurred. Provider shall promptly take all appropriate or legally required corrective actions and shall cooperate fully with the Agency in all reasonable and lawful efforts to prevent, mitigate or rectify such data breach. In the event of a suspected breach, Provider shall keep the Agency informed of the progress of its investigation until the uncertainty is resolved.
- J. In the event the Provider does not carry the appropriate cyber security insurance to cover a security breach, the Provider shall reimburse the Agency for actual costs incurred, including, but not limited to, providing clients affected by a security breach with notice of the breach, and/or complimentary access for credit monitoring services, which the Agency deems necessary to protect such affected client.
- K. In the event the Agency discontinues operation, all child records for residential or any other placement settings shall be provided to the custodial agency. If the setting is licensed by ODJFS, licensing records shall be sent to:

ODJFS
ATTN: Licensing
P.O. Box 183204
Columbus, OH 43218-3204

Article XI. PROVIDER ASSURANCES AND CERTIFICATIONS

- A. As applicable to the Provider's license and/or certification, the Provider certifies compliance with ORC 2151.86, ORC 5103.0328, ORC 5103.0319 and applicable OAC Sections as defined in Article XXII of this Agreement concerning criminal record checks, arrests, convictions and guilty pleas relative to foster caregivers, employees, volunteers and interns who are involved in the care for a child. Provider is responsible for any penalties, financial or otherwise, that may accrue because of noncompliance with this provision.
- B. To the extent that the Provider maintains a residential center or group home, the Provider agrees to comply with the provisions of their licensing Agency that relates to the operation, safety and maintenance of residential facilities. Specifically, Provider agrees that no firearm or other projectile weapon and no ammunition for such weapons will be kept on the premises.
- C. Provider certifies compliance with Drug Free Work Place Requirements as outlined in 45 C.F.R. Part 76, Subpart F.
- D. Provider certifies compliance with 45 C.F.R. Part 80, Non-Discrimination under programs receiving Federal assistance through the Department of Health and Human Services effectuation of Title VI of the Civil Rights Act of 1964.
- E. Provider certifies compliance with 45 C.F.R. Part 84, Non-Discrimination on the Basis of Handicap in Programs or Activities Receiving Federal Assistance.
- F. Provider certifies compliance 45 C.F.R. Part 90, Non-Discrimination on the Basis of Age in Programs or Activities Receiving Federal Assistance.
- G. Provider certifies compliance with the American with Disabilities Act, Public Law 101-336.
- H. Provider certifies that it will:
 - 1. Provide a copy of its license(s), certification, accreditation or a letter extending an expiring license, certification, or accreditation from the issuer to the Agency prior to the signing of the Agreement.
 - 2. Maintain its license(s), certification, accreditation and that upon receipt of the renewal of its license, certification, and/or accreditation or upon receipt of a letter extending an expiring license, certification, and/or accreditation from the issuer, a copy of the license, certification and/or accreditation will be provided to the Agency within five (5) business days.
 - 3. Provider shall immediately notify the Agency of any action, modification or issue relating to said licensure, accreditation or certification.
- I. Provider certifies that it will not deny or delay services to eligible persons because of the person's race, color, religion, national origin, gender, orientation, disability, or age.
- J. The Provider shall comply with Executive Order 11246, entitled Equal Employment Opportunity, as amended by Executive Order 11375, and as supplemented in Department of Labor regulation 41 CFR part 60.
- K. Provider further agrees to comply with OAC 5101:9-2-01 and OAC 5101:9-2-05(A)(4), as applicable, which require that assure that persons with limited English proficiency (LEP) can meaningfully access services. To the extent Provider provides assistance to an LEP Child through the use of an oral or written translator or interpretation services in compliance with this requirement, the LEP Child shall not be required to pay for such assistance.
- L. To the extent applicable, the Provider certifies compliance with all applicable standards, orders, or requirements issued under Section 306 of the Clean Air Act (42 U.S.C. 1857 (h) Section 508 of the Clean Water Act (33 U.S.C. 1368), Executive Order 11738, and Environmental Protection Agency Regulations (40 C.F.R. Part 15).
- M. The Provider certifies compliance, where applicable, with mandatory standards and policies relating to energy efficiency which are contained in the state energy conservation plan issued in compliance with the Energy Policy and Conservation Act (Pub. L. 94-163, 89 Stat. 871).
- N. The Provider certifies that all approvals, licenses, or other qualifications necessary to conduct business in Ohio have been obtained and are current.
- O. Provider shall comply with the Small Business Job Protection Act (Public Law ("P.L.") 104-188), the Multiethnic

Placement Act of 1994 (P.L. 103-382), Titles IV-B (42 U.S.C. 620 et seq.) and IV-E (42 U.S.C. 670 et seq.) of the Social Security Act ("the Act"), the Personal Responsibility and Work Opportunity Reconciliation Act of 1996 (P.L. 104-193), Section 471(a) of Title IV-E of the Act (42 U.S.C. 671(a)), and 45 C.F.R. 1356, including all rules, regulations and guidelines issued by federal and state authorities, OAC 5101:9-4-07 and OAC 5101:2-47-23.1.

Article XII. INDEPENDENT CONTRACTOR

- A. The Provider and the Agency agree that no employment, joint venture, or partnership has been or will be created between the parties hereto pursuant to the terms and conditions of this Agreement.
- B. The Provider and the Agency agree that the Provider is an independent contractor and assumes all responsibility for any federal, state, municipal, or other tax liabilities along with workers' compensation, unemployment compensation, and insurance premiums which may accrue as a result of compensation received for services or Deliverables rendered hereunder.
- C. The Provider and the Agency agree that no person and/or entities entering into this Agreement, nor any individual employed by any person or entity entering in to this Agreement, are public employees for purposes of contributions to Ohio Public Employees Retirement system by virtue of any work performed or services rendered in accordance with this Agreement.

Article XIII. AUDITS AND OTHER FINANCIAL MATTERS

- A. Provider agrees to submit to Agency a copy of the independent audit it receives in accordance with ORC 5103.0323.
- B. Upon request from the Agency, Provider shall submit a copy of the most recent Federal income tax return and related schedules filed with the Internal Revenue Service (IRS).
- C. If Provider participates in the Title IV-E program, Provider agrees to timely file its Title IV-E cost report with all required items as outlined in OAC 5101:2-47-26.2 to ODJFS. Provider agrees that in the event a cost report cannot be timely filed, an extension shall be requested prior to the December 31st filing deadline.
- D. If a Provider participates in the Title IV-E program, an Agreed Upon Procedures engagement must be conducted by a certified public accountant for the Provider's cost report in accordance with OAC 5101:2-47-26.2. The procedures are conducted to verify the accuracy of costs used to establish reimbursement ceilings for maintenance and administration costs of child in care. Any overpayments or underpayment of federal funds to the Title IV-E Agency due to adjustments of cost report reimbursement ceiling amounts as a result of an audit, shall be resolved in accordance with ORC 5101.11, ORC 5101.14, and OAC 5101:2-47-01.
- E. Upon request from the Agency, the Provider shall submit a copy of the JFS 02911 and Agreed Upon Procedures.
- F. For financial reporting purposes and for Title IV-E cost reporting purposes, Provider agrees to follow the cost principles set forth in the following OAC Sections and publications:
 - 1. OAC 5101:2-47-11: "Reimbursement for foster care maintenance costs for child's residential centers, group homes, maternity homes, residential parenting facilities, and purchased family foster care facilities".
 - 2. OAC 5101:2-47-26.1: "Public child services agencies (PCSA), private child placing agencies (PCPA), private noncustodial agencies (PNA), residential care facilities, substance use disorder (SUD) residential facilities: Title IV-E cost report filing requirements, record retention requirements, and related party disclosure requirements";
 - 3. OAC 5101:2-47-26.2: "Cost Report Agreed Upon Procedures Engagement".
 - 4. JFS 02911 Single Cost Report Instructions.
 - 5. For Private Agencies: 2 CFR part 225, Cost Principles for State, Local and Indian Tribal Government.
 - 6. For Public Agencies: 2 CFR part 230, Cost Principles for Non-Profit Organizations.
 - 7. 2 CFR part 200:501, Audit Requirements.

Article XIV. GRIEVANCE /DISPUTE RESOLUTION PROCESS

In the event that a dispute arises under the provisions of this Agreement, the parties shall follow the procedures set forth below:

- 1. The party complaining of a dispute shall provide written notice of the nature of the dispute to the other party to this Agreement. A copy of the notice shall be sent to the Director or designee of the Agency and to the Executive Director or designee of the Provider. Within ten (10) business days of receiving the notice of a dispute, the parties involved in the dispute between the Agency and the Provider shall attempt to resolve the dispute.
- 2. If the parties are unable to resolve the dispute in (1 business day), the highest official or designee of the Agency

shall make the final determination within twenty (20) business days, which will be non-binding.

3. Neither party will be deemed to have waived any other rights or remedies available to them by initiating, participating in or completing this process.

Article XV. AMENDMENTS

This Agreement, Addenda, and all Exhibits hereto constitutes the entire Agreement and may be amended only with a written amendment signed by both parties; however, it is agreed by the parties that any amendments to laws or regulations cited herein will result in the correlative modification of this Agreement, without the necessity for executing written amendments. The impact of any applicable law, statute, or regulation not cited herein and enacted after the date of execution of this Agreement will be incorporated into this Agreement by written amendment signed by both parties and effective as of the date of enactment of the law, statute, or regulation. Any other written amendment to this Agreement is prospective in nature.

Article XVI. NOTICE

Unless otherwise set forth herein, all notices, requests, demands and other communications pertaining to this Agreement shall be in writing and shall be deemed to have been duly given if delivered or mailed by certified or registered mail, postage pre-paid:

if to Agency, to	Warren County Children Services 416 S East St Lebanon, OH 45036
if to Provider, to	FuturePromise 1701 Kinney Ave Cincinnati, OH 45207

Article XVII. CONSTRUCTION

This Agreement shall be governed, construed, and enforced in accordance with the laws of the State of Ohio. Should any portion of this Agreement be found to be unenforceable by operation of statute or by administrative or judicial decision, the operation of the balance of this Agreement is not affected thereby; provided, however, the absence of the illegal provision does not render the performance of the remainder of the Agreement impossible.

Article XVIII. NO ASSURANCES

- A. Provider acknowledges that, by entering into this Agreement, Agency is not making any guarantees or other assurances as to the extent, if any, that Agency shall utilize Provider's services or purchase its goods. In this same regard, this Agreement in no way precludes, prevents, or restricts Provider from obtaining and working under additional arrangement(s) with other parties, assuming the work in no way impedes Provider's ability to perform the services required under this Agreement. Provider warrants that at the time of entering into this Agreement, it has no interest in nor shall it acquire any interest, direct or indirect, in any Agreement that will impede its ability to provide the goods or perform the services under this Agreement.
- B. This Agreement, Addenda, and all Exhibits embodies the entire agreement of the Parties. There are no promises, terms, conditions or obligations other than those contained herein; and this Agreement shall supersede all previous communications, representations or Agreements, either written or oral, between the parties to this Agreement. Also, this Agreement shall not be modified in any manner except by an instrument, in writing, executed by both the parties.

Article XIX. CONFLICT OF INTEREST

- A. Provider agrees that the Provider, its officers, members and employees currently have no, nor will they acquire any interest, whether personal, professional, direct or indirect, which is incompatible, in conflict with or which would compromise the discharge and fulfillment of Provider's functions, duties and responsibilities hereunder. If the Provider, or any of its officers, members or employees acquire any incompatible, conflicting, or compromising personal or professional interest, the Provider shall immediately disclose, in writing, such interest to the Agency. If any such conflict of interest develops, the Provider agrees that the person with the incompatible, conflicting, or compromising personal or professional interest will not participate in any activities related to this Agreement.
- B. Provider agrees: (1) to refrain from promising or giving to Agency employees anything of value to manifest improper influence upon the employee; (2) to refrain from conflicts of interest; and, (3) to certify that Provider complies with ORC 102.03, ORC 102.04, ORC 2921.42, ORC 2921.43.

- C. The Provider further agrees that there is no financial interest involved on the part of the Agency or the respective county authority(ies) governing the agency. The Provider has no knowledge of any situation which would be a conflict of interest. It is understood that a conflict of interest occurs when an Agency employee or county official will gain financially or receive personal favors as a result of signing or implementation of this agreement. The Provider will report the discovery of any potential conflict of interest to the Agency. Should a conflict of interest be discovered during the term of this agreement, the Agency may exercise any right under the agreement, including termination of the agreement.

Article XX. INSURANCE

The Provider shall purchase and maintain for the term of this Agreement insurance of the types and amounts identified herein. Maintenance of the proper insurance for the duration of the Agreement is a material element of the Agreement.

Provider agrees to procure and maintain for the term of this Agreement the insurance set forth herein. The cost of all insurance shall be borne by Provider. Insurance shall be purchased from a company licensed to provide insurance in Ohio. Insurance is to be placed with an insurer provided an A.M. Best rating of no less than A-. Provider shall purchase the following coverage and minimum limits:

- A. Commercial general liability insurance policy with coverage contained in the most current Insurance Services Office Occurrence Form CG 00 01 or equivalent with limits of at least One Million Dollars (\$1,000,000.00) per occurrence and One Million Dollars (\$1,000,000.00) in the aggregate and at least One Hundred Thousand Dollars (\$100,000.00) coverage in legal liability fire damage. Coverage will include:
1. Additional insured endorsement;
 2. Product liability;
 3. Blanket contractual liability;
 4. Broad form property damage;
 5. Severability of interests;
 6. Personal injury; and
 7. Joint venture as named insured (if applicable).
- Endorsements for physical abuse claims and for sexual molestation claims must be a minimum of Three Hundred Thousand Dollars (\$300,000.00) per occurrence and Three Hundred Thousand Dollars (\$300,000.00) in the aggregate.
- B. Business auto liability insurance of at least One Million Dollars (\$1,000,000.00) combined single limit, on all owned, non-owned, leased and hired automobiles. If the Agreement contemplates the transportation of the users of County services (such as but not limited to Agency consumers), "Consumers" and Provider provides this service through the use of its employees' privately owned vehicles "POV", then the Provider's Business Auto Liability insurance shall sit excess to the employees "POV" insurance and provide coverage above its employee's "POV" coverage. Provider agrees the business auto liability policy will be endorsed to provide this coverage.
- C. Professional liability (errors and omission) insurance of at least One Million Dollars (\$1,000,000.00) per claim and in the aggregate.
- D. Umbrella and excess liability insurance policy with limits of at least One Million Dollars (\$1,000,000.00) per occurrence and in the aggregate, above the commercial general and business auto primary policies and containing the following coverage:
1. Additional insured endorsement;
 2. Pay on behalf of wording;
 3. Concurrence of effective dates with primary;
 4. Blanket contractual liability;
 5. Punitive damages coverage (where not prohibited by law);
 6. Aggregates: apply where applicable in primary;
 7. Care, custody and control – follow form primary; and
 8. Drop down feature.

The amounts of insurance required in this section for General Liability, Business Auto Liability and Umbrella/Excess Liability may be satisfied by Provider purchasing coverage for the limits specified or by any combination of underlying and umbrella limits, so long as the total amount of insurance is not less than the limits specified in General Liability, Business Auto Liability and Umbrella/Excess Liability when added together.

E. Workers' Compensation insurance at the statutory limits required by Ohio Revised code.

F. The Provider further agrees with the following provisions:

1. All policies, except workers' compensation and professional liability, will endorse as additional insured the Board of County Commissioners, and Agency and their respective officials, employees, agents, and volunteers, including their Board of Trustees if applicable. The additional insured endorsement shall be on an ACORD or ISO form.
2. The insurance endorsement forms and the certificate of insurance forms will be sent to the Agency Director or Designee. The forms must state the following: "Board of County Commissioners, and Agency and their respective officials, employees, agents, and volunteers are endorsed as additional insured as required by agreement on the commercial general, business auto and umbrella/excess liability policies."
3. Each policy required by this clause shall be endorsed to state that coverage shall not be canceled or materially changed except after thirty (30) calendar days prior written notice given to the Agency Director or Designee.
4. Provider shall furnish the Agency with original certificates and amendatory endorsements effecting coverage required by this clause. All certificates and endorsements are to be received by the Agency before the Agreement commences. The Agency reserves the right at any time to require complete, certified copies of all required insurance policies, including endorsements affecting the coverage required by these specifications.
5. Failure of the Agency to demand such certificate or other evidence of full compliance with these insurance requirements or failure of the Agency to identify a deficiency from evidence provided shall not be construed as a waiver of Provider's obligation to maintain such insurance.
6. Provider shall declare any self-insured retention to the Agency pertaining to liability insurance. Provider shall provide a financial guarantee satisfactory to the Agency guaranteeing payment of losses and related investigations, claims administration and defense expenses for any self-insured retention.
7. If Provider provides insurance coverage under a "claims-made" basis, Provider shall provide evidence of either of the following for each type of insurance which is provided on a claims-made basis: unlimited extended reporting period coverage, which allows for an unlimited period of time to report claims from incidents that occurred after the policy's retroactive date and before the end of the policy period (tail coverage), or; continuous coverage from the original retroactive date of coverage. The original retroactive date of coverage means original effective date of the first claim-made policy issued for a similar coverage while Provider was under Agreement with the County on behalf of the Agency.
8. Provider will require all insurance policies in any way related to the work and secured and maintained by Provider to include endorsements stating each underwriter will waive all rights of recovery, under subrogation or otherwise, against the County and the Agency. Provider will require of subcontractors, by appropriate written agreements, similar waivers each in favor of all parties enumerated in this section.
9. Provider, the County, and the Agency agree to fully cooperate, participate, and comply with all reasonable requirements and recommendations of the insurers and insurance brokers issuing or arranging for issuance of the policies required here, in all areas of safety, insurance program administration, claim reporting and investigating and audit procedures.
10. Provider's insurance coverage shall be primary insurance with respect to the County, the Agency, their respective officials, employees, agents, and volunteers. Any insurance maintained by the County or the Agency shall be excess of Provider's insurance and shall not contribute to it.
11. If any of the work or Services contemplated by this Agreement is subcontractors, Provider will ensure that any subcontractors comply with all insurance requirements contained herein.
12. If the Agreement provider is a government entity, insurance requirements will be fulfilled under the County Risk Sharing Authority (CORSAs).

Article XXI. INDEMNIFICATION & HOLD HARMLESS

- A. To the fullest extent permitted by, and in compliance with, applicable law, Provider agrees to protect, defend, indemnify and hold harmless the Agency and the Board of County Commissioners, their respective members, officials, employees, agents, and volunteers (the "Indemnified Parties") from and against all damages, liability, losses, claims, suits, actions, administrative proceedings, regulatory proceedings/hearings, judgments and expenses, subrogation (of any party involved in the subject of this Agreement), attorneys' fees, court costs, defense costs or other injury or damage (collectively "Damages"), whether actual, alleged or threatened, resulting from injury or damages of any kind whatsoever to any business, entity or person (including death), or damage to property (including destruction, loss of, loss of use of resulting without injury damage or destruction) of whatsoever nature, arising out of or incident to in any way, the performance of the terms of this Agreement including, without limitation, by Provider, its subcontractor(s), Provider's or its subcontractor(s) employees,

agents, assigns, and those designated by Provider to perform the work or services encompassed by the Agreement. Provider agrees to pay all damages, costs and expenses of the Indemnified Parties in defending any action arising out of the aforementioned acts or omissions.

- B. Each Party agrees to be responsible for any personal injury or property damage caused solely by its negligent acts or omissions as determined by a court of competent jurisdiction, or as the parties may otherwise mutually agree in writing.
- C. This Article is not applicable to Agreements between governmental entities.

Article XXII. SCREENING AND SELECTION

A. Criminal Record Check

- 1. Provider warrants and represents it will comply with Article X as it relates to criminal record checks. Provider shall insure that every individual subject to a BCII check will sign a release of information to allow inspection and audit of the above criminal records transcripts or reports by the Agency or a private vendor hired by the Agency to conduct compliance reviews on their behalf.
- 2. Provider shall not assign any individual to work with or transport children until a BCII report and a criminal record transcript has been obtained.
- 3. Except as provided in Section C below, Provider shall not utilize any individual who has been convicted or plead guilty to any violations contained in ORC 5153.111(B)(1), ORC 2919.24, and OAC Chapters 5101:2-5, 5101:2-7, 5101:2-48.
- 4. Provider agrees to be financially responsible for any audit findings resulting in financial penalty due to lack of compliance with the criminal records checks requirements in OAC Chapters 5101:2-5, 5101:2-7, 5101:2-48.

B. Transportation of Child

- 1. The caregiver shall ensure the transportation of children in care will be reliable, legal and safe transportation with safety restraints, as appropriate for the child, and must be in compliance with applicable local, state and Federal transportation laws:
 - a. Maintenance of a current valid driver's license and vehicle insurance.
 - b. All children being transported by Provider must follow Ohio's Child Passenger Safety Law as defined in ORC 4511.81.
 - c. No child that is a passenger and is required to have a seat restraint can be transported by said provider until these requirements are met.
- 2. In addition to the requirements set forth above, Provider shall not permit any individual to transport a Child if:
 - a. The individual has a condition which would affect safe operation of a motor vehicle;
 - b. The individual has six (6) or more points on his/her driver's license; or
 - c. The individual has been convicted of, or pleaded guilty to, a violation of section 4511.19 (Operating vehicle under the influence of alcohol or drugs – OVI or OVUAC) of the Revised Code if the individual previously was convicted of, or plead guilty to two or more violations within the three years immediately preceding the current violation.

C. Rehabilitation

- 1. Notwithstanding the above, Provider may make a request to the Agency to utilize an individual if Provider believes the individual has met the rehabilitative standards of OAC 5101:2-07-02(I) as follows:
 - a. If the Provider is seeking rehabilitation for a foster caregiver, a foster care applicant or other resident of the foster caregiver's household, Provider must provide written verification that the rehabilitative standards of OAC 5101:2-7-02 have been met.
 - b. If the Provider is seeking rehabilitation for any other individual serving Agency children, Provider must provide written verification from the individual that the rehabilitative conditions in accordance with OAC 5101:2-5-09 have been met.
- 2. The Agency shall review the facts presented and may allow the individual to work with, volunteer with or transport Agency children on a case-by-case basis. It is the Agency's sole discretion to permit a rehabilitated individual to work with, volunteer with or transport children.

D. Verification of Job or Volunteer Application:

Provider shall check and document each applicant's personal and employment references, general work history, relevant experience, and training information. Provider further agrees it will not employ an individual in relation to this Agreement unless it has received satisfactory employment references, work history, relevant experience, and training information.

Article XXIII. PROHIBITION OF CORPORAL & DEGRADING PUNISHMENT

Agency prohibits the use of corporal or degrading punishment against children served by Agency and must comply with requirements in OAC 5101:2-7-09, OAC 5101:2-9-21, and OAC 5101:2-9-22

Article XXIV. FINDING FOR RECORDS

ORC 9.24 prohibits public agencies from awarding an Agreement for goods, services, or construction paid for in whole or in part from federal, state and local funds, to an entity against whom a finding for recovery has been issued if the finding is unresolved. By entering into this Agreement, Provider warrants and represents that they do not have an unresolved finding for recovery. Provider shall notify the Agency within ten (10) business days of its notification should the Provider be issued such finding by the Auditor of the State.

Article XXV. PUBLIC RECORDS

This Agreement is a matter of public record under the Ohio public records law. By entering into this Agreement, Provider acknowledges and understands that records maintained by Provider pursuant to this Agreement may also be deemed public records and subject to disclosure under Ohio law. Upon request made pursuant to Ohio law, the Agency shall make available the Agreement and all public records generated as a result of this Agreement.

Article XXVI. CHILD SUPPORT ENFORCEMENT

Provider agrees to cooperate with ODJFS and any Ohio Child Support Enforcement Agency ("CSEA") in ensuring Provider and Provider's employees meet child support obligations established under state or federal law. Further, by executing this Agreement, Provider certifies present and future compliance with any court or valid administrative order for the withholding of support which is issued pursuant to the applicable sections in ORC Chapters 3119, 3121, 3123, and 3125.

Article XXVII. DECLARATION OF PROPERTY TAX DELINQUENCY

After award of an Agreement, and prior to the time the Agreement is entered into, the successful Provider shall submit a statement in accordance with ORC 5719.042. Such statement shall affirm under oath that the person with whom the Agreement is to be made was not charged at the time the bid was submitted with any delinquent personal property taxes on the general tax list of personal property of any county in which the taxing district has territory, or that such person was charged with delinquent personal property taxes on any such tax list, in which case the statement shall also set forth the amount of such due and unpaid delinquent taxes any due and unpaid penalties and interest thereon. If the statement indicates that the taxpayer was charged with any such taxes, a copy of the statement shall be transmitted by the fiscal officer to the county treasurer within thirty days of the date it is submitted.

A copy of the statement shall also be incorporated into the Agreement, and no payment shall be made with respect to any contract to which this section applies unless such statement has been so incorporated as a part thereof.

Article XXVIII. SUBCONTRACTING AND DELEGATION

The performance of any duty, responsibility or function which is the obligation of the Provider under this Agreement may be delegated or subcontracted to any agent or subcontractor of Provider if Provider has obtained the prior written consent of the Agency for that delegation subcontract. Provider is responsible for ensuring that the duties, responsibilities or functions so delegated or subcontracted are performed in accordance with the provisions and standards of this Agreement, and the actions and omissions of any such agent or subcontractor shall be deemed to be the actions and omissions of Provider for purposes of this Agreement.

Article XXIX. PROPERTY OF AGENCY

The Deliverable(s) and any item(s) provided or produced pursuant to this Agreement (collectively called "Deliverables") will be considered "works made for hire" within the meaning of copyright laws of the United States of America and the State of Ohio. The Agency is the sole author of the Deliverables and the sole owner of all rights therein. If any portion of the Deliverables are deemed not to be a "work made for hire", or if there are any rights in the Deliverables not so conveyed to the Agency, then Provider agrees to, and by executing this Agreement hereby does, assign to the Agency all worldwide rights, title, and interest in and to the Deliverables. The Agency acknowledges that its sole ownership of the Deliverables under this Agreement does not affect Provider's right to use general concepts, algorithms, programming techniques, methodologies, or technology that have been developed by Provider prior to this Agreement or that are generally known and available. Any Deliverable provided or produced by Provider under this Agreement or with funds hereunder, including any documents, data, photographs and negatives, electronic reports/records, or other media, are the property of the Agency, which has an unrestricted right to reproduce, distribute, modify, maintain, and use the Deliverables. Provider shall not obtain copyright, patent, or other proprietary protection for the Deliverables. Provider shall not include in any Deliverable any copyrighted material, unless the copyright owner gives prior written approval for the Agency and Provider to use such copyrighted material. Provider agrees that all Deliverables will be made freely available to the general public unless the Agency determines that, pursuant to state or federal law, such materials are confidential or otherwise exempt from disclosure.

Article XXX. SEVERABILITY

If any term of this Agreement or its application thereof to any person or circumstance shall to any extent be held invalid or unenforceable, the remainder of this Agreement, or the application of such term or provision to persons or circumstances other than those as to which it is held invalid or unenforceable, shall not be affected thereby. Each term and provision of this Agreement shall be valid and enforced to the fullest extent permitted by law.

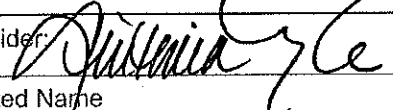
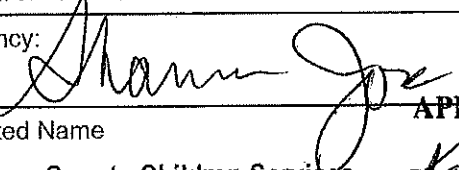

Article XXXI. NO ADDITIONAL WAIVER IMPLIED

If the Agency or Provider fails to perform any obligations under this Agreement and thereafter such failure is waived by the other party, such waiver shall be limited to the particular matter waived and shall not be deemed to waive any other failure hereunder, nor a waiver of a subsequent breach of the same provision or condition. Waivers shall not be effective unless in writing.

Article XXXII. APPLICABLE LAW AND VENUE

This Agreement and any modifications, amendments, or alterations, shall be governed, construed, and enforced under the laws of Ohio. Any legal action brought pursuant to this agreement will be filed in the Ohio courts, and Ohio law as well as Federal law will apply. IN WITNESS WHEREOF, the parties have executed this Agreement as of the date of the signature of the parties.

SIGNATURES OF PARTIES:

Provider: 	07/04/2019
Printed Name	Date
Future Promise	
Agency: 	8-20-19
Printed Name	Date
Warren County Children Services 	

APPROVED AS TO FORM

**Kathryn M. Horvath
Asst. Prosecuting Attorney**

Ohio Department of Job and Family Services
**AGREEMENT FOR TITLE IV-E AGENCIES AND PROVIDERS FOR THE PROVISION
OF
CHILD PLACEMENT**

ADDENDA TO AGREEMENT

This Addenda sets forth the terms and conditions between the parties for placement services for children who are in the care and custody of the Agency named below.

This Agreement is between

a Title IV-E Agency, hereinafter "Agency," whose address is

hereinafter "Provider," whose address is:

IV-E Agency Name Warren County Children Services		
Street/Mailing Address 416 S East St		
City Lebanon	State OH	Zip Code 45036

and

Provider FuturePromise		
Street/Mailing Address 1701 Kinney Ave		
City Cincinnati	State OH	Zip Code 45207

Contract ID : 19141959

Originally Dated :06/01/2019 to 03/31/2020

Ohio Department of Job and Family Services
**AGREEMENT FOR TITLE IV-E AGENCIES AND PROVIDERS FOR
THE PROVISION
OF
CHILD PLACEMENT**

Amendment Number 1 :

Amendment Reason:

OTHER

Amendment Begin Date:

06/01/2019

Amendment End Date :

03/31/2020

Increased Amount:

\$0.00

Article Name:

Article I. Scope of Placement Services

Amendment Reason Narrative:

Addendum #1 attached. See Addendum #1 for details.

Title IV-E Schedule A Rate Information

Title IV-E Schedule A Rate Information
 Agency : Warren County Children Services
 Run Date: 06/19/2019
 Provider / ID : FuturePromise/ 22501187
 Contract Period : 06/01/2019 - 03/31/2020

Service Description	Service ID	Person ID	Person ID	Maintenance Per Diem	Administration Per Diem	Case Management Per Diem	Transportation / Administration Per Diem	Transportation / Maintenance Per Diem	Other Direct Services Per Diem	Behavioral Healthcare Per Diem	Other Per Diem Cost	Total Per Diem	Cost Begin Date	Cost End Date
Group : 7233664 Home				\$237.98	\$16.22							\$254.20	06/01/2019	03/31/2020

**ADDENDUM 1 TO AGREEMENT FOR TITLE IV-E AGENCIES AND PROVIDERS
FOR THE PROVISION OF CHILD PLACEMENT**

WHEREAS, the parties to the Agreement seek to amend certain terms and conditions of the Ohio Department of Job and Family Services standard Agreement for Title IV-E Agencies and Providers for the Provision of Child Placement;

NOW, WHEREFORE, the parties agree that the Agreement shall include the following Amendments, additional terms, and conditions that address Provider and Agency responsibilities.

AMENDMENT #1:

The following provision shall be added to Article V of the Agreement:

“Any notification required pursuant to subsections (G), (H), or (I) of Article V shall require verbal contact with an Agency representative. Leaving a voicemail shall not constitute notification under these sections.”

AMENDMENT #2:


Article VI, subsection (H) of the Agreement shall be amended as follows:

The language that states “thirty (30) calendar days” shall be replaced with “twenty-four (24) hours, not to exceed thirty (30) calendar days.”

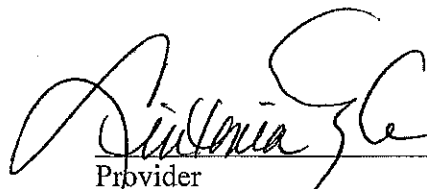
ALL TERMS AND CONDITIONS OF THE STANDARD AGREEMENT NOT SPECIFICALLY AMENDED, MODIFIED, ADDED, OR DELETED HEREBY SHALL REMAIN IN FULL FORCE AND EFFECT.

IN WITNESS WHEREOF, the parties hereto have executed this Addendum to the Agreement by the President of the Warren County Board of Commissioners, pursuant to Resolution Number 19-1069, dated 8-20-19, and by the duly authorized _____ of _____ [Provider].

SIGNATURES OF PARTIES:

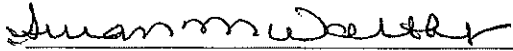


President
Warren County Board of Commissioners
Date 8-20-19



Provider
Date 07132019

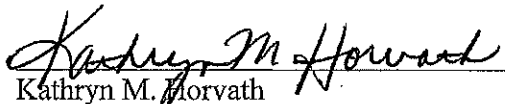
Reviewed by:



Director

Warren County Children's Services

Approved as to Form:



Kathryn M. Howard

Assistant Prosecuting Attorney

**State of Ohio
Department of Job and Family Services**

**John R. Kasich
Governor**

This is to Certify that

**FUTUREPROMISE
1019 HOLDERNESS LANE
CINCINNATI, OHIO 45240
(CERTIFICATION- STUDY# 82103)**

Has been inspected pursuant to Chapter 5103, of the Ohio Revised Code and applicable Ohio Administrative Code rules.

The specific functions which the agency is certified to perform are listed below and explained in detail in the accompanying letter.

To operate a Group Home(s)

To operate or provide Independent Living arrangements

This certificate is effective From October 31, 2018 To October 30, 2020

Temporary certificate expiration date To _____

Unless sooner revoked or amended by the Ohio Department of Job and Family Services



Ohio

**Bureau of Workers'
Compensation**

30 W. Spring St.
Columbus, OH 43215

Certificate of Ohio Workers' Compensation

This certifies that the employer listed below participates in the Ohio State Insurance Fund as required by law. Therefore, the employer is entitled to the rights and benefits of the fund for the period specified. This certificate is only valid if premiums and assessments, including installments, are paid by the applicable due date. To verify coverage, visit www.bwc.ohio.gov, or call 1-800-644-6292.

This certificate must be conspicuously posted.

Policy number and employer
80048068

Period Specified Below
07/01/2019 to 07/01/2020

Future Promise
PO BOX 40599
CINCINNATI, OH 45240-0599



www.bwc.ohio.gov
Issued by: BWC

Stephanie B. McCloud
Administrator/CEO

You can reproduce this certificate as needed.

Ohio Bureau of Workers' Compensation

Required Posting

Section 4123.54 of the Ohio Revised Code requires notice of rebuttable presumption. Rebuttable presumption means an employee may dispute or prove untrue the presumption (or belief) that alcohol, marihuana or a controlled substance not prescribed by the employee's physician is the proximate cause (main reason) of the work-related injury.

The burden of proof is on the employee to prove the presence of alcohol, marihuana or a controlled substance was not the proximate cause of the work-related injury. An employee who tests positive or refuses to submit to chemical testing may be disqualified for compensation and benefits under the Workers' Compensation Act.

Ohio

**Bureau of Workers'
Compensation**

You must post this language with the Certificate of Ohio Workers' Compensation.



FUTUPRO-02

GBONNER

CERTIFICATE OF LIABILITY INSURANCE

 DATE (MM/DD/YYYY)
 07/10/2019

THIS CERTIFICATE IS ISSUED AS A MATTER OF INFORMATION ONLY AND CONFERS NO RIGHTS UPON THE CERTIFICATE HOLDER. THIS CERTIFICATE DOES NOT AFFIRMATIVELY OR NEGATIVELY AMEND, EXTEND OR ALTER THE COVERAGE AFFORDED BY THE POLICIES BELOW. THIS CERTIFICATE OF INSURANCE DOES NOT CONSTITUTE A CONTRACT BETWEEN THE ISSUING INSURER(S), AUTHORIZED REPRESENTATIVE OR PRODUCER, AND THE CERTIFICATE HOLDER.

IMPORTANT: If the certificate holder is an **ADDITIONAL INSURED**, the policy(ies) must have **ADDITIONAL INSURED** provisions or be endorsed. If **SUBROGATION IS WAIVED**, subject to the terms and conditions of the policy, certain policies may require an endorsement. A statement on this certificate does not confer rights to the certificate holder in lieu of such endorsement(s).

PRODUCER Cincinnati/ AssuredPartners NL 5905 E. Galbraith Rd., Suite 5000 Cincinnati, OH 45236	CONTACT NAME: Gwen Bonner PHONE (A/C, No, Ext): (513) 624-1773 FAX (A/C, No): (513) 333-0735 E-MAIL ADDRESS: gwen.bonner@assuredpartners.com														
INSURED FuturePromise 1019 Holderness LN Cincinnati, OH 45240	<table border="1" style="width: 100%; border-collapse: collapse;"> <thead> <tr> <th style="width: 80%;">INSURER(S) AFFORDING COVERAGE</th> <th style="width: 20%;">NAIC #</th> </tr> </thead> <tbody> <tr> <td>INSURER A: Nova Casualty Company</td> <td>42552</td> </tr> <tr> <td>INSURER B:</td> <td></td> </tr> <tr> <td>INSURER C:</td> <td></td> </tr> <tr> <td>INSURER D:</td> <td></td> </tr> <tr> <td>INSURER E:</td> <td></td> </tr> <tr> <td>INSURER F:</td> <td></td> </tr> </tbody> </table>	INSURER(S) AFFORDING COVERAGE	NAIC #	INSURER A: Nova Casualty Company	42552	INSURER B:		INSURER C:		INSURER D:		INSURER E:		INSURER F:	
INSURER(S) AFFORDING COVERAGE	NAIC #														
INSURER A: Nova Casualty Company	42552														
INSURER B:															
INSURER C:															
INSURER D:															
INSURER E:															
INSURER F:															

COVERAGES **CERTIFICATE NUMBER:** **REVISION NUMBER:**

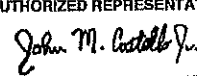
THIS IS TO CERTIFY THAT THE POLICIES OF INSURANCE LISTED BELOW HAVE BEEN ISSUED TO THE INSURED NAMED ABOVE FOR THE POLICY PERIOD INDICATED. NOTWITHSTANDING ANY REQUIREMENT, TERM OR CONDITION OF ANY CONTRACT OR OTHER DOCUMENT WITH RESPECT TO WHICH THIS CERTIFICATE MAY BE ISSUED OR MAY PERTAIN, THE INSURANCE AFFORDED BY THE POLICIES DESCRIBED HEREIN IS SUBJECT TO ALL THE TERMS, EXCLUSIONS AND CONDITIONS OF SUCH POLICIES. LIMITS SHOWN MAY HAVE BEEN REDUCED BY PAID CLAIMS.

INSR LTR	TYPE OF INSURANCE	ADDL INSD	SUBR WVD	POLICY NUMBER	POLICY EFF (MM/DD/YYYY)	POLICY EXP (MM/DD/YYYY)	LIMITS		
A	<input checked="" type="checkbox"/> COMMERCIAL GENERAL LIABILITY	X		CF1-ML-10002559-00	02/01/2019	02/01/2020	EACH OCCURRENCE	\$ 1,000,000	
	<input type="checkbox"/> CLAIMS-MADE <input checked="" type="checkbox"/> OCCUR						DAMAGE TO RENTED PREMISES (Ea occurrence)	\$ 100,000	
	<input checked="" type="checkbox"/> Profess Liab						MED EXP (Any one person)	\$ 5,000	
	<input checked="" type="checkbox"/> Abuse/Molestation						PERSONAL & ADV INJURY	\$ 1,000,000	
	GEN'L AGGREGATE LIMIT APPLIES PER:							GENERAL AGGREGATE	\$ 3,000,000
	<input checked="" type="checkbox"/> POLICY <input type="checkbox"/> PRO-JECT <input type="checkbox"/> LOC						PRODUCTS - COMP/OP AGG	\$ 3,000,000	
	<input checked="" type="checkbox"/> OTHER: Employee Benefits							\$	
	AUTOMOBILE LIABILITY						COMBINED SINGLE LIMIT (Ea accident)	\$	
	<input type="checkbox"/> ANY AUTO OWNED AUTOS ONLY						BODILY INJURY (Per person)	\$	
	<input type="checkbox"/> HIRED AUTOS ONLY						BODILY INJURY (Per accident)	\$	
	<input type="checkbox"/> SCHEDULED AUTOS						PROPERTY DAMAGE (Per accident)	\$	
	<input type="checkbox"/> NON-OWNED AUTOS ONLY							\$	
A	<input checked="" type="checkbox"/> UMBRELLA LIAB	X		CF1-UM-10000617-00	02/01/2019	02/01/2020	EACH OCCURRENCE	\$ 1,000,000	
	<input type="checkbox"/> EXCESS LIAB						AGGREGATE	\$	
	<input checked="" type="checkbox"/> RETENTION \$ 10,000						Aggregate	\$ 1,000,000	
	WORKERS COMPENSATION AND EMPLOYERS' LIABILITY						PER STATUTE	OTH-ER	
	ANY PROPRIETOR/PARTNER/EXECUTIVE OFFICER/MEMBER EXCLUDED? (Mandatory in NH)		N/A				E.L. EACH ACCIDENT	\$	
	If yes, describe under DESCRIPTION OF OPERATIONS below						E.L. DISEASE - EA EMPLOYEE	\$	
							E.L. DISEASE - POLICY LIMIT	\$	
A	Hired/Non-Owned Auto	X		CF1-ML-10002559-00	02/01/2019	02/01/2020	Hired/Non-Owned Auto	1,000,000	

DESCRIPTION OF OPERATIONS / LOCATIONS / VEHICLES (ACORD 101, Additional Remarks Schedule, may be attached if more space is required)

Employers' Liability -
 Each Accident \$1,000,000
 Disease - Each Employee \$1,000,000
 Disease - Policy Limit \$1,000,000

Cyber Liability -
 Information/Security & Privacy \$1,000,000 claim/aggregate
 SEE ATTACHED ACORD 101

CERTIFICATE HOLDER Board of Warren County Commissioners Warren County Children Services 416 S East St Lebanon, OH 45036	CANCELLATION SHOULD ANY OF THE ABOVE DESCRIBED POLICIES BE CANCELLED BEFORE THE EXPIRATION DATE THEREOF, NOTICE WILL BE DELIVERED IN ACCORDANCE WITH THE POLICY PROVISIONS. AUTHORIZED REPRESENTATIVE 
--	--



ADDITIONAL REMARKS SCHEDULE

AGENCY Cincinnati/ AssuredPartners NL		NAMED INSURED FuturePromise 1019 Holderness LN Cincinnati, OH 45240	
POLICY NUMBER SEE PAGE 1			
CARRIER SEE PAGE 1	NAIC CODE SEE P 1	EFFECTIVE DATE: SEE PAGE 1	

ADDITIONAL REMARKS

THIS ADDITIONAL REMARKS FORM IS A SCHEDULE TO ACORD FORM,
 FORM NUMBER: ACORD 25 FORM TITLE: Certificate of Liability Insurance

Description of Operations/Locations/Vehicles:
 Regulatory Action (Defense & Penalties) \$1,000,000 claim/aggregate
 Website-Media Content \$1,000,000 claim/aggregate
 Privacy Breach Response \$1,000,000 claim/aggregate

Crime -
 Employee Theft \$100,000

The Certificate Holder is listed as additional insured as per written contract and Form AGL 09 27 07-17.

THIS ENDORSEMENT CHANGES THE POLICY. PLEASE READ IT CAREFULLY.

SOCIAL SERVICES - GENERAL LIABILITY EXTRA ENDORSEMENT

This endorsement modifies insurance provided under the following:

COMMERCIAL GENERAL LIABILITY COVERAGE PART

A. SECTION I – COVERAGES, COVERAGE A - BODILY INJURY AND PROPERTY DAMAGE LIABILITY,

Paragraph 2. **Exclusions** is amended as follows:

1. EXPECTED OR INTENDED INJURY EXTENSION

Paragraph a. **Expected Or Intended Injury** is deleted and replaced by the following:

- a. "Bodily injury" or "property damage" expected or intended from the standpoint of the insured. This exclusion does not apply to "bodily injury" or "property damage" resulting from the use of reasonable force to protect persons or property.

2. NON OWNED AIRCRAFT CHARTERED WITH CREW EXTENSION

Paragraph g. **Aircraft, Auto Or Watercraft** is amended to add an exception provision to the exclusion as follows:

- a. This exclusion does not apply to aircraft chartered with crew to any insured.
- b. This exception provision does not apply if the chartered aircraft is owned by any insured.
- c. This insurance is excess over any other valid and collectible insurance available to the insured whether primary, excess, or contingent.

3. NON OWNED WATERCRAFT EXTENSION

Subparagraph (2) of g. **Aircraft, Auto Or Watercraft** is deleted and replaced by the following:

(2) A watercraft you do not own that is:

- (a) Less than 60 feet long; and
- (b) Not being used to carry persons or property for a charge;

This provision applies to any person who, with your consent, either uses or is responsible for the use of a watercraft.

This insurance is excess over any other valid and collectible insurance available to the insured for aircraft, auto or watercraft whether primary, excess, or contingent.

4. PROPERTY SOLD OR ABANDONED BY YOU

Subparagraph (2) of j. **Damage To Property** is deleted and replaced by the following:

- (2) Premises you sell, give away or abandon, if the "property damage" arises out of any part of those premises, and occurred from hazards that were known by you or should have reasonably been known by you at the time the property was sold, given away or abandoned.

5. DAMAGE TO PREMISES RENTED TO YOU

- a. The last Paragraph of 2. **Exclusions** is deleted and replaced by the following:

Exclusions c. through n. do not apply to damage to premises while rented to you, or temporarily occupied by you with the permission of the owner, when the damage is caused by fire, lightning, explosion, smoke, water or leaks from automatic fire protective systems. A separate limit of insurance applies to this coverage as described in **SECTION III – LIMITS OF INSURANCE**.

- b. Paragraph 6. of **SECTION III – LIMITS OF INSURANCE** is deleted and replaced by the following:

6. Subject to Paragraph 5. above, the Damage To Premises Rented To You Limit is the most we will pay under Coverage A for damages because of "property damage" to any one premises while rented to you, or temporarily occupied by you with permission of the owner, caused by fire, lightning, explosion, smoke, water or leaks from automatic fire protective systems. The Damage To Premises Rented To You limit will apply to all damage proximately caused by the same "occurrence", whether such damage results from fire, lightning, explosion, smoke, water or leaks from automatic fire protective systems, or any combination of any of these.

The Damage To Premises Rented To You Limit will be the higher of:

- (1) \$1,000,000; or
- (2) The amount shown on the Declarations for Damage To Premises Rented To You.

6. INVITEE PROPERTY DAMAGE LEGAL LIABILITY

- a. The following is added to subparagraph (4) of j. **Damage To Property**:

However, this exclusion does not apply to "property damage" to your "invitee's" personal property in your care, custody or control caused by fire, lightning, explosion, smoke, water, leaks from automatic fire protective systems; or vandalism or malicious mischief:

- (a) On premises you own or rent or on ways next to premises you own or rent; and
- (b) Arising out of your operations.

For the purposes of this endorsement, personal property does not include any of the following:

- (c) Accounts, bills, currency, food stamps or other evidences of debt; deeds, money, notes, or securities;
- (d) Contraband, or property in the course of illegal transportation or trade; or
- (e) Blueprints, documents, drawings, manuscripts, records or valuable papers.

b. The following is added to SECTION III – LIMITS OF INSURANCE:

Subject to Paragraph 5. above, the most we will pay under Coverage A for the sum of all damages sustained by all "invitees" because of "property damage" to personal property of such "invitees" in your care, custody or control is \$15,000.

7. Paragraph 2. Exclusions is amended to add the following exclusion:

Willful Violation Of A Penal Code Or Statute

"Bodily injury", "incidental medical malpractice liability" or "property damage" arising out of the willful violation of a penal code, statute or regulation relating to the sale or distribution of pharmaceuticals by or with the knowledge or consent of the insured.

B. SECTION I – COVERAGES, COVERAGE B – PERSONAL AND ADVERTISING INJURY LIABILITY,

Paragraph 2. Exclusions is amended as follows:

1. Subparagraph a. **Knowing Violation Of Rights Of Another** is amended to add the following:
This exclusion does not apply to "personal and advertising injury" caused by malicious prosecution.
2. Subparagraph e. **Contractual Liability** is deleted and replaced by the following:
 - e. Advertising injury for which the insured has assumed liability in a contract or agreement. This exclusion does not apply to liability for damages that the insured would have in the absence of the contract or agreement.

This provision does not apply if **COVERAGE B - PERSONAL AND ADVERTISING INJURY LIABILITY** is excluded by endorsement.

C. SUPPLEMENTARY PAYMENTS – COVERAGES A AND B, Paragraph 1. is amended as follows:

1. The limit in subparagraph b. is increased to \$2,500.
2. The limit in subparagraph d. is increased to \$500 a day.

D. ADDITIONAL INSURED

1. **SECTION II - WHO IS AN INSURED** is amended to include, as an additional insured, any person(s) or organization(s) for whom a written contract or written agreement between you and such person(s) or organization(s) exists and requires such person(s) or organizations(s) to be added as an additional insured to your Policy, but only for liability arising out of "bodily injury," "property damage" or "personal and advertising injury".
 - a. This endorsement applies only if the written contract or written agreement is:
 - (1) Currently in effect or becomes effective during the term of this Policy; and
 - (2) Executed prior to the "bodily injury", "property damage", or "personal and advertising injury".
 - b. The insurance afforded to such additional insured only:
 - (1) Applies to the extent permitted by law; and
 - (2) Will not be broader than that which you are required by the written contract or written agreement to provide for such additional insured.
2. The insurance provided to the additional insured by this endorsement applies as follows:
 - a. The person(s) or organization(s) is an additional insured but only for liability caused in whole or in part by your acts or omissions or the acts or omissions of those acting on your behalf:
 - (1) In connection with your premises owned by or rented to you; or
 - (2) In the performance of your ongoing operations.
 - b. If the additional insured is an architect, engineer or surveyor, this insurance does not apply to "bodily injury", "property damage" or "personal and advertising injury" arising out of the rendering of or failure to render any professional services including:

COMMERCIAL GENERAL LIABILITY

- (1) The preparing, approving, or failing to prepare or approve maps, drawings, opinions, reports, surveys, change orders, designs or specifications; or
- (2) Supervisory, inspection or engineering services.

This exclusion applies even if the claims against any insured allege negligence or other wrongdoing in the supervision, hiring, employment, training or monitoring of others by that insured if the "occurrence" which caused the "bodily injury" or "property damage" or the offense which caused the "personal and advertising injury" involved the rendering of or the failure to render any professional services by or for you.

- c. If the additional insured is a lessor of equipment, this insurance only applies to liability caused, in whole or in part, by your maintenance, operation or use of equipment leased to you by such additional insured and does not apply to any "occurrence" which takes place after the equipment lease expires.
- d. If the additional insured is a state or governmental agency or political subdivision and has issued a permit in connection with premises you own, rent or control, this insurance applies only with respect to the following hazards for which the state or political subdivision has issued such permit:
 - (1) The existence, maintenance, repair, construction, erection, or removal of advertising signs, awnings, canopies, cellar entrances, coal holes, driveways, manholes, marquees, hoist away openings, sidewalk vaults, street banners or decoration and similar exposures;
 - (2) The construction, erection or removal of elevators; or
 - (3) The ownership, maintenance, or use of any elevators covered by this insurance.
- e. If the additional insured is a state or governmental agency or political subdivision that has issued a permit or authorization with respect to operations performed by you or on your behalf, then this insurance does not apply to:
 - (1) "Bodily injury", "property damage" or "personal and advertising injury" arising out of operations performed for the federal government, state or municipality; or
 - (2) "Bodily injury" or "property damage" included within the "products-completed operations hazard".
- f. If the additional insured is a manager or lessor of insured premises, that person or organization is an additional insured only with respect to liability arising out of the ownership, maintenance or use of that part of the premises leased to you.

This insurance does not apply to:

 - (1) Any "occurrence" that takes place after you cease to be a tenant in that premises; or
 - (2) Structural alterations, new construction or demolition operations performed by or on behalf of the manager or lessor of insured premises.
- g. If the additional insured is grantor of franchise, that person(s) or organization(s) is only an additional insured with respect to liability as grantor of a franchise to you.
- h. If the additional insured is an owner or other interest from whom land has been leased, that person(s) or organization(s) is only an additional insured with respect to liability arising out of the ownership, maintenance or use of that part of the land leased to you.

This insurance does not apply to:

 - (1) Any "occurrence" that takes place after you cease to lease that land; or
 - (2) Structural alterations, new construction or demolition operations performed by or on behalf of the owner or other interest from whom land has been leased.
- i. If the additional insured is a mortgagee, assignee, or receiver, that person(s) or organization(s) is only an additional insured with respect to their liability as such and arising out of the ownership, maintenance or use of the premises by you.

This insurance does not apply to structural alterations, new construction or demolition operations performed by or for that mortgagee, assignee or receiver.
- j. If the additional insured is a controlling interest, that person(s) or organization(s) is an additional insured but only for their liability arising out of:
 - (1) Their financial control of you; or
 - (2) Premises they own, maintain or control while you lease or occupy those premises.
 - (3) Their requirements for certain performance placed upon you, as a non-profit organization, in consideration for funding or financial contributions you receive from them; or

As respects Paragraph j.(2) above, this insurance does not apply to:

 - (4) Structural alterations, new construction or demolition operations performed by or on behalf of the person or organization; or
 - (5) Any "occurrence" which takes place after you cease to be a tenant in that premises.

- k. If the additional insured is a vendor, that person(s) or organization(s) is only an additional insured with respect to "bodily injury" or "property damage" arising out of "your products" which are distributed or sold in the regular course of the vendor's business, but only if this Policy provides coverage for "bodily injury" or "property damage" included within the "products-completed operations hazard".
 - (1) This insurance afforded to the vendor does not apply to:
 - (a) "Bodily injury" or "property damage" for which the vendor is obligated to pay damages by reason of the assumption of liability in a contract or agreement. This exclusion does not apply to liability for damages that the vendor would have in the absence of the contract or agreement;
 - (b) Any express warranty unauthorized by you;
 - (c) Any physical or chemical change in the product made intentionally by the vendor;
 - (d) Repackaging, except when unpacked under the instructions of the manufacturer for the sole purpose of inspection, demonstration, testing or the substitution of parts and then repackaged in the original container;
 - (e) Any failure by the vendor to make inspections, adjustments, tests or servicing as the vendor has agreed to make or normally undertakes to make in the usual course of business, in connection with the distribution or sale of "your products";
 - (f) Demonstration, installation, servicing or repair operations, except such operations performed at the vendor's premises in connection with the sale of "your products";
 - (g) Products which, after distribution or sale by you, have been labeled or relabeled or used as a container, part or ingredient of any other thing or substance by or for the vendor; or
 - (h) "Bodily injury" or "property damage" arising out of the sole negligence of the vendor for its own acts or omissions or those of its employees or anyone else acting on its behalf. However, this exclusion does not apply to:
 - (i) The exceptions contained in subparagraphs k.(d) or k.(f); or
 - (ii) Such inspections, adjustments, tests or servicing as the vendor has agreed to make or normally undertakes to make in the usual course of business, in connection with the distribution or sale of "your products".
 - (2) This insurance does not apply to any insured person or organization, from whom you have acquired such products, or any ingredient, part or container, entering into, accompanying or containing such products.
 - l. If the additional insured is a member or volunteer this insurance only applies with respect to their liability for your activities or activities they perform on your behalf.
 - m. If the additional insured is a trustee or member of the Board of Governors this insurance only applies with respect to their duties as such.
3. With respect to the insurance afforded to an additional insured as provided in Paragraphs D.1. and D.2. above, the most we will pay on behalf of the additional insured is the amount of insurance:
 - a. Required by the contract or agreement; or
 - b. Available under the applicable Limits of Insurance shown in the Declarations; whichever is less.
 4. With respect to the insurance afforded to an additional insured as provided in Paragraphs D.1. and D.2. above, this insurance shall not increase the applicable Limits of Insurance shown in the Declarations.
 5. If an Additional Insured endorsement is attached to this Policy that specifically names a person or organization as an insured, then the above subsection D. **ADDITIONAL INSURED**s does not apply to such person(s) or organization(s).
 6. Paragraph 4. **Other Insurance** of **SECTION IV – COMMERCIAL GENERAL LIABILITY CONDITIONS** is amended to include:
 For the purposes of the coverage provided by this endorsement, regardless of whether other insurance is available to an additional insured on a primary basis, this insurance will be primary and noncontributory if a written contract between you and the additional insured specifically requires that this insurance be primary and noncontributory.

E. SECTION II - WHO IS AN INSURED is amended as follows:

1. BROADENED NAMED INSURED

Paragraph 3. is deleted and replaced by the following:

3. Any business entity organized under the laws of the United States of America (including any state thereof, its territories or possessions), or Canada (including any province thereof) will qualify as a

Named Insured if there is no similar insurance available to that business entity, provided that one or more Named Insureds shown in the Declarations have, at the inception of the policy period, an ownership interest in such business entity of more than 50%. However, if a Named Insured has an ownership interest in a business entity of more than 50%, the business entity will not be a Named Insured if such business entity is an insured under any other liability policy or would be an insured under such policy but for its termination or the exhaustion of its Limit of Insurance.

2. CO-EMPLOYEE COVERAGE AND CO-VOLUNTEER WORKERS

Subparagraphs (a), (b) and (c) under Paragraph 2.a.(1) do not apply to "bodily injury" for which insurance is provided as follows:

- a. Your "employees" are insureds with respect to "bodily injury" to a co-"employee" in the course of the co-"employee's" employment by you, or to your "volunteer workers" while performing duties related to the conduct of your business, provided that this coverage for your "employees" does not apply to acts outside the scope of their employment by you or while performing duties unrelated to the conduct of your business.
- b. Your "volunteer workers" are insureds with respect to "bodily injury" to a co-"volunteer worker" while performing duties related to the conduct of your business, or to your "employees" in the course of the "employees" employment by you, provided that this coverage for your "volunteer workers" does not apply while performing duties unrelated to the conduct of your business.

3. INCIDENTAL MEDICAL MALPRACTICE – EMPLOYED NURSES, EMT'S AND PARAMEDICS

- a. Paragraph 2.a.(1)(d) does not apply to any registered nurse, licensed practical nurse, emergency medical technician or paramedic employed by you, but only:

(1) While performing the services described in the definition of "incidental medical malpractice injury"; and

(2) When acting within the scope of their employment by you.

Any "employees" rendering "Good Samaritan Services" will be deemed to be acting within the scope of their employment by you.

- b. For the purposes of determining the applicable Limits of Insurance, any act or omission, together with all related acts or omissions in the furnishing of services for an "incidental medical malpractice injury" to any one person, will be considered one "occurrence".
- c. This provision as provided in Paragraph 3.a. and 3.b. does not apply if:
 - (1) You are in the business or occupation of providing any of the services described in "incidental medical malpractice injury"; or
 - (2) An endorsement is attached to this Policy that specifically provides liability coverage for registered or licensed practical nurses.
- d. The insurance provided by Paragraph 3.a. and 3.b. shall be excess over any other valid and collectible insurance available to the insured, whether primary, excess, contingent or on any other basis, except for insurance purchased specifically by you to be excess of this Policy.

4. LIABILITY FOR CONDUCT OF UNNAMED PARTNERSHIP OR JOINT VENTURE

- a. The last Paragraph of SECTION II – WHO IS AN INSURED is deleted and replaced by the following: No person or organization is an insured with respect to the conduct of any current or past partnership, joint venture, limited liability company or trust that is not shown as a Named Insured in the Declarations. This subparagraph does not apply to your liability with respect to your conduct of the business of any current or past partnership or joint venture that is not shown as a Named Insured in the Declarations.

- b. SECTION IV – COMMERCIAL GENERAL LIABILITY CONDITIONS, Paragraph 4.b. Excess Insurance is amended to add the following:

This insurance is excess over any valid and collectible other insurance, whether primary, excess, contingent or on any other basis, which is available to you for your liability with respect to your conduct of the business of any current or past partnership or joint venture that is not shown as a Named Insured in the Declarations and which is issued to such partnership or joint venture.

F. SECTION IV – COMMERCIAL GENERAL LIABILITY CONDITIONS is amended as follows:

1. KNOWLEDGE AND NOTICE OF OCCURRENCE, OFFENSE, CLAIM OR SUIT

The notification requirements of Paragraphs 2.a. and 2.b. Duties In The Event Of Occurrence, Offense, Claim Or Suit apply only when the "occurrence", offense, claim or "suit" is known to:

- a. You, if you are an individual;
- b. A partner or member, if you are a partnership or joint venture;

- c. An officer or director, if you are an entity other than a partnership, joint venture or limited liability company;
- d. A member or manager, if you are a limited liability company; or
- e. An insurance manager, risk manager or other "employee" you designate prior to loss to give notice to us.

Knowledge of an "occurrence", offense, claim, or "suit" by your agent, servant or "employee" shall not in and of itself constitute knowledge by you unless an individual in one of the positions listed above has actual knowledge.

2. FAILURE TO DISCLOSE HAZARDS

The following is added to Paragraph **6. Representations**:

If you unintentionally failed to disclose all hazards or prior "occurrences" existing at the inception of this Policy, but reported such error or omission to us as soon as practicable after discovery, we will not deny coverage under this Coverage Part because of such failure.

This provision does not affect our right to collect any additional premium or exercise our right of cancellation or non-renewal.

3. SPECIAL EVENT PREMIUM RATING

The following is added:

Special Event Premium Rating

a. The rating for this endorsement includes the following special events:

- (1) All indoor special events with less than 2,500 attendees that are less than 24 hours in duration; and
- (2) All outdoor special events with less than 2,500 attendees that are less than 24 hours in duration.

b. The following special events shall be separately rated for additional premium:

- (1) Any special event that exceeds the number or attendees or duration as shown in 3.a.(1) or 3.a.(2) above;
- (2) Any parade, fair or carnival; or
- (3) Any athletic, sporting or motor vehicle event including walks, runs, tournaments, demonstrations, rallies or competitive activities.

4. WAIVER OF TRANSFER OF RIGHTS OF RECOVERY AGAINST OTHERS TO US

The following is added to Paragraph **8. Transfer Of Rights of Recovery Against Others To Us**:

We waive any right of recovery we may have against any person or organization when such waiver is required by a written contract that you have agreed to prior to any "occurrence", "suit" or the offense which caused the "bodily injury", "property damage" or "personal and advertising injury", provided that the "occurrence", "suit" or the offense which caused the "bodily injury", "property damage" or "personal and advertising injury" arises out of operations contemplated by such contract. The waiver applies only to the person or organization designated in such contract.

G. SECTION V – DEFINITIONS is amended as follows:

1. BODILY INJURY

The definition of "bodily injury" in Paragraph **3.** is deleted and replaced by the following:

"Bodily injury" means bodily injury, "incidental medical malpractice injury", mental anguish, mental injury, shock, fright, disability, humiliation, sickness or disease sustained by a person, including death resulting from any of these at any time.

2. PERSONAL AND ADVERTISING INJURY

If **COVERAGE B – PERSONAL AND ADVERTISING INJURY LIABILITY** is not otherwise excluded from this Policy, the definition in Paragraph **14.b.** is deleted and replaced by the following:

- b. Malicious prosecution or abuse of process;

The following is added:

"Personal and advertising injury" also means "discrimination" or humiliation that results in injury to a natural person or their reputation, but only if such discrimination or humiliation is:

- (a) Not done intentionally by or at the direction of, or with the knowledge or consent of:
 - i. Any insured; or
 - ii. Any executive officer, director, stockholder, partner or member of any insured organization;
- (b) Not directly or indirectly related to the employment, former or prospective employment, termination of employment, or application for employment, of any person or persons by any insured;
- (c) Not prohibited by or held in violation of law, public policy, legislation, court decision or administrative

ruling;
 (d) Not arising out of any "advertisement" by the insured.

3. INSURED CONTRACT

- a. Subparagraph a. of the definition of "insured contract" is deleted and replaced by the following:
 - a. A contract for a lease of premises.
- b. Subparagraph f. of the definition of "insured contract" is deleted and replaced by the following:
 - f. That part of any other contract or agreement pertaining to your business (including an indemnification of a municipality in connection with work performed for a municipality) under which you assume the tort liability of another party to pay for "bodily injury" "property damage" or "personal and advertising injury" to a third party or organization. Tort liability means a liability that would be imposed by law in the absence of any contract or agreement.

4. PRODUCTS-COMPLETED OPERATIONS HAZARD

The definition of "products-completed operations hazard" in Paragraph 16. is amended to add the following:

Includes all "bodily injury" and "property damage" arising out of your "designated products" on premises you own or rent; on premises used by you for a special event related to your business; or on connecting lots, or premises whose connection is interrupted only by a street, roadway, waterway or right-of-way of a railroad, next to any such premises you own or rent, or use for a special event.

For the purpose of this definition, "designated products" means apparel, buttons, CD's, DVD's, posters, stickers, tapes and other similar products used to promote a special event related to your business.

The following definitions are added:

- 5. "Discrimination" means:
 - a. Unfair treatment of a natural person or organization including but not limited to discrimination based upon race, color, ethnic or national origin, religion, age, gender, marital status, sexual orientation or preference, pregnancy, physical disability or impairment, or mental disability or impairment; or
 - b. Any act or conduct that would be considered "discrimination" under any applicable federal, state, or local statute, ordinance or law.
- 6. "Good Samaritan services" means those medical services rendered or provided in an emergency and for which no remuneration is requested or paid.
- 7. "Incidental medical malpractice injury" means "bodily injury", mental anguish, sickness or disease sustained by a person, including death resulting from any of these at any time, arising out of the rendering of, or failure to render, the following services:
 - a. Medical, surgical, dental, laboratory, x-ray or nursing service or treatment, advice or instruction, or the related furnishing of food or beverages;
 - b. The furnishing or dispensing of drugs or medical, dental, or surgical supplies or appliances; or
 - c. First aid.
- 8. "Invitee" means any of your clients, customers, guests, members, patrons, supporters, and "volunteer workers"; however, it does not include any person who is your "employee", "temporary worker" or independent contractor.

All other terms and conditions of the policy remain unchanged.

Resolution

Number 19-1070

Adopted Date August 20, 2019

APPROVE THE DESTRUCTION OF THE FOLLOWING WARREN COUNTY SHERIFF'S OFFICE EQUIPMENT.

WHEREAS, the Warren County Sheriff's Office has determined there is no longer any service left in the following;

- Canon PowerShot A520 Camera, ID 19322, has internal memory that can't be destroyed
- Canon PowerShot A590 Camera, ID 6622374149, has internal memory that can't be destroyed
- Canon PowerShot A300 Camera, ID 7226423961, has internal memory that can't be destroyed
- Canon PowerShot A630 Camera, ID 3126259794, has internal memory that can't be destroyed
- Canon PowerShot ELPH180 Camera, ID 462063020488, has internal memory that can't be destroyed
- Fujifilm FinePix S1500 Camera, ID 23103, has internal memory that can't be destroyed
- Apple Ipad , ID 25489, has internal memory that can't be destroyed
- Cisco Adaptive Security Appliance, ID 23130, has internal memory that can't be destroyed
- Destroyed TV from Jail Lobby, ID 26064, already destroyed by inmate

WHEREAS, the Warren County Sheriff's Office plans to dispose of the items properly; and

NOW THEREFORE BE IT RESOLVED, to dispose of the above listed property.

Mr. Young moved for adoption of the foregoing resolution being seconded by Mr. Grossmann. Upon call of the roll, the following vote resulted:

Mrs. Jones – yea
Mr. Grossmann – yea
Mr. Young – yea

Resolution adopted this 20th day of August 2019.

BOARD OF COUNTY COMMISSIONERS



Tina Osborne, Clerk

cc: Sheriff (file)
Auditor- B. Quillen

Resolution

Number 19-1071

Adopted Date August 20, 2019

REJECT BIDS RECEIVED FOR THE LILY DRIVE BRIDGE #1023-0.17 REPLACEMENT PROJECT

WHEREAS, bids were received by the Board of Commissioners for the Lily Drive Bridge #1023-0.17 Replacement Project on Tuesday, August 6, 2019 @ 9:30 a.m.; and

WHEREAS, the bids received were 10% over the engineer's estimate, so all the bids submitted for this project have been rejected; and

NOW THEREFORE BE IT RESOLVED, to reject all bids received for the Lily Drive Bridge #1023-0.17 Replacement Project, and to re-advertise for said project at a later date.

Mr. Young moved for adoption of the foregoing resolution being seconded by Mr. Grossmann. Upon call of the roll, the following vote resulted:

Mrs. Jones – yea
Mr. Grossmann – yea
Mr. Young – yea

Resolution adopted this 20th day of August 2019.

BOARD OF COUNTY COMMISSIONERS



Tina Osborne, Clerk

KH/

cc: Engineer (file)
OMB Bid file

*BOARD OF COUNTY COMMISSIONERS
WARREN COUNTY, OHIO*

Resolution

Number 19-1072

Adopted Date August 20, 2019

APPROVE AND ENTER INTO AGREEMENT WITH OHIO-KENTUCKY-INDIANA
REGIONAL COUNCIL OF GOVERNMENTS

BE IT RESOLVED, to approve and enter into contract with Ohio-Kentucky-Indiana Regional
Council of Governments for 2019 funding; said agreement attached hereto and made a part hereof.

Mr. Young moved for adoption of the foregoing resolution being seconded by Mr. Grossmann.
Upon call of the roll, the following vote resulted:

Mrs. Jones – yea
Mr. Grossmann – yea
Mr. Young – yea

Resolution adopted this 20th day of August 2019.

BOARD OF COUNTY COMMISSIONERS



Tina Osborne, Clerk

/to

cc: c/a—OKI Regional Council of Government
Commissioners' file
OMB

AGREEMENT

THIS AGREEMENT is effective on the 1st day of July 2019, by and between the OHIO-KENTUCKY-INDIANA REGIONAL COUNCIL OF GOVERNMENTS, herein called the "Council" and WARREN COUNTY, OHIO herein called the "Funding Agency".

WHEREAS, the Funding Agency has determined that it has a need for regional planning operations and that such regional planning operations can be most advantageously pursued through Federally-assisted comprehensive regional planning services; and

WHEREAS, the Council has been organized to and does provide continuing comprehensive regional planning services through Federally-assisted projects in the regional area composed of Boone, Campbell and Kenton Counties in the Commonwealth of Kentucky; Butler, Clermont, Hamilton and Warren Counties in the State of Ohio; and Dearborn County in the State of Indiana, herein called the "OKI Region"; and

WHEREAS, the Council requires financial support from the Funding Agency in order to continue its regional planning activities and

WHEREAS, the Funding Agency, upon due consideration, has determined that the continued operation of council is necessary and vital function for the metropolitan region of which this funding Agency is part.

IT IS NOW, THEREFORE, AGREED AS FOLLOWS:

1. The Funding Agency shall pay the Council the sum of \$76,617.00. Said amount shall be paid in two installments; the first installment in an amount of \$38,308.50 to be due at contract execution and the second installment of \$38,308.50 to be due December 1, 2019.

2. In consideration of such payments, the Council or assignee shall render regional

planning services to the Funding Agency and to the OKI Region. Said services may include, but are not limited to, the following items specified in the Fiscal Year 2020 Operating Budget of the council: Transportation Planning, Mass Transit Planning, Regional Planning, Economic Development Activities, Air Quality Planning, Water Quality Planning and Ridesharing Activities, as more specifically described in applicable contracts between the Council and agencies of the United States government, which have been executed and which may be from time to time executed, all of which are on file with the Council and available upon request to the Funding Agency.

3. The term of this Agreement shall be from the date first written above through the end of the Council's fiscal year, June 30, 2020, and until all payments contracted for hereunder have been made.

4. It is understood and agreed by the parties hereto that the Council may assign its rights hereunder to a lending institution. Upon written notification by Council and such institution of such assignment, the Funding Agency agrees to make payments pursuant to Paragraph 1 hereof as directed in such writing and the Council agrees that payments made pursuant to such an assignment shall discharge the Funding Agency's obligation to the Council hereunder the same as if such payments were made directly to the Council. This Agreement shall not be assignable otherwise than as set forth herein.

5. The funding Agency represents to the Council that:

- a) The Funding Agency has the power to enter into this agreement;
- b) The Funding Agency has taken all such actions as may be necessary to lawfully appropriate funds sufficient to make the payments called for in this Agreement;
- c) The Funding Agency has taken all action as may be necessary to lawfully

execute this agreement;


- d) When executed, this Agreement shall be a legal, enforceable and binding obligation upon The Funding Agency in accord with its terms.

6. This Agreement contains all the terms agreed upon between the parties with respect to the subject matter thereof. This Agreement may be amended or modified only by a written instrument executed by both parties.

IN WITNESS THEREOF, this Agreement to have been executed by authorized officers or agents, on this 20th day of August, 2019.

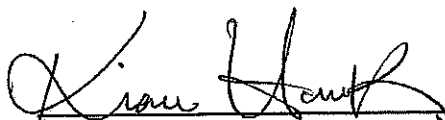
**OHIO-KENTUCKY-INDIANA REGIONAL
COUNCIL OF GOVERNMENTS**


BY: _____
MARK R. POLICINSKI, EXECUTIVE DIRECTOR



ATTEST

WARREN COUNTY, OHIO


BY: _____
**WARREN COUNTY BOARD OF
COMMISSIONERS**


ATTEST

APPROVED AS TO FORM


Adam M. Nice
Asst. Prosecuting Attorney

Resolution

Number 19-1073

Adopted Date August 20, 2019

AUTHORIZE COUNTY ADMINISTRATOR TO EXECUTE CHANGE ORDER #3 WITH HGC CONSTRUCTION RELATIVE TO THE WARREN COUNTY PROBATE/JUVENILE COURT ADDITION AND RENOVATION PROJECT

WHEREAS, pursuant to Resolution #18-1294, ADOPTED August 14, 2018 this Board entered into contract with HGC Construction relative to the Warren County Probate/Juvenile Court Addition and Renovation Project; and

WHEREAS, the Judge had requested to add VCT flooring at the Secure Corridor in the new addition as well as a concrete patio at the rear entrance of the new addition; and

WHEREAS, the HGC Construction has advised that there is "buy out savings" on the project to accommodate the cost associated with this change order and will not affect the current Guaranteed Maximum Price;

NOW THEREFORE BE IT RESOLVED, to authorize the County Administrator, to execute change order #3 with HGC Construction, in the amount zero dollars resulting in no change to the current contract price of \$4,323,705.57;

Mr. Young moved for adoption of the foregoing resolution being seconded by Mr. Grossmann. Upon call of the roll, the following vote resulted:

Mrs. Jones – yea
Mr. Grossmann – yea
Mr. Young – yea

Resolution adopted this 20th day of August 2019.

BOARD OF COUNTY COMMISSIONERS



Tina Osborne, Clerk

Tz/

cc: c/a—HGC Construction
Probate/Juvenile Ct (file)
Commissioners file
Facilities Management



Design-Build Change Order Form

For Use with DBIA Document No. 525, *Standard Form of Agreement Between Owner and Design-Builder – Lump Sum* (2010 Edition) and DBIA Document No. 530, *Standard Form of Agreement Between Owner and Design-Builder – Cost Plus Fee with an Option for A Guaranteed Maximum Price* (2010 Edition)

Change Order Number: 003	Change Order Effective Date: 8/6/2019 <small>(date when executed by both parties)</small>
Project: Warren County Probate Juvenile Court Expansion	Design Builder's Project No: 118017
Owner: Warren County Board of Commissioners	Date of Agreement: 8/6/2018
	Design Builder: HGC Construction

Scope of the Change:

Proposed Change Order: Owner Requested Change Order (ORC) #3 for the following changes in the contract:

<u>Description</u>	<u>Amount</u>
Add VCT Flooring at Secure Corridor	1,593.24
Add Concrete Patio	8,918.00
Buyout Savings	<u>-10,511.24</u>
Total For Change Order:	0.00

Original Contract Price:	<u>\$ 350,000.00</u>
Net Change by Previous Change Order No(s): 1 to 2	<u>\$ 3,973,705.57</u>
This Change Order Increase/Decrease (attach breakdown):	<u>\$ 0.00</u>
New Contract Price:	<u>\$ 4,323,705.57</u>

Original Contract Completion Date:	November 5, 2019
Adjustments by Change Order No(s): 1 to 2	<u>0</u> (Calendar days)
This Change Order Contract Time Increase/Decrease:	<u>0</u> (Calendar days)
Revised Substantial Completion Date:	November 5, 2019

By executing this Change Order, Owner and Design-Builder agree to modify the Agreement's Scope of Work, Contract Price and Contract Time as stated above. Upon execution, this Change Order becomes a Contract Document issued in accordance with DBIA Document No. 535, *Standard Form of General Conditions of Contract Between Owner and Design-Builder*, (2010 Edition).

OWNER: Warren County Board of Commissioners

DESIGN-BUILDER: HGC Construction

By: Tiffany Zindel
Printed Name: Tiffany Zindel
Title: County Administrator
Date: 8-20-19

By: Adam Kuehne
Printed Name: Adam Kuehne
Title: VP of Operations
Date: 8/6/19

OWNER:

DESIGN-BUILDER:

By: _____
Printed Name: _____
Title: _____
Date: _____

By: _____
Printed Name: _____
Title: _____
Date: _____

OWNER:

DESIGN-BUILDER:

By: _____
Printed Name: _____
Title: _____
Date: _____

By: _____
Printed Name: _____
Title: _____
Date: _____

**BOARD OF COUNTY COMMISSIONERS
WARREN COUNTY, OHIO**

Resolution

Number 19-1074

Adopted Date August 20, 2019

DECLARE VARIOUS ITEMS WITHIN BOARD OF ELECTION, BUILDING & ZONING, COMMON PLEAS COURT- DOMESTIC RELATIONS, DRUG TASK FORCE, FACILITIES MANAGEMENT, JUVENILE COURT, AND SHERIFF'S OFFICE, WATER & SEWER - WATER DEPARTMENT AS SURPLUS AND AUTHORIZE THE DISPOSAL OF SAID ITEMS

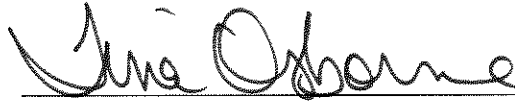
BE IT RESOLVED, to authorize disposal of various items from Board of Election, Building & Zoning, Common Pleas Court- Domestic Relations, Drug Task Force, Facilities Management, Juvenile Court, Sheriff's Office and Water & Sewer- Water Department in accordance with the Ohio Revised Code; list of said items attached hereto and made a part hereof.

Mr. Young moved for adoption of the foregoing resolution being seconded by Mr. Grossmann. Upon call of the roll, the following vote resulted:

Mrs. Jones – yea
Mr. Grossmann – yea
Mr. Young – yea

Resolution adopted this 20th day of August 2019.

BOARD OF COUNTY COMMISSIONERS



Tina Osborne, Clerk

/sr

cc: 2019 Auction file
Facilities Management (file)
Brenda Quillen, Auditor's Office

Warren County Facilities Management

GovDeals #

B&Z19004

430 South East Street
513-695-1463

Michael D. Shadoan
Director

GovDeals Item Inspection Form

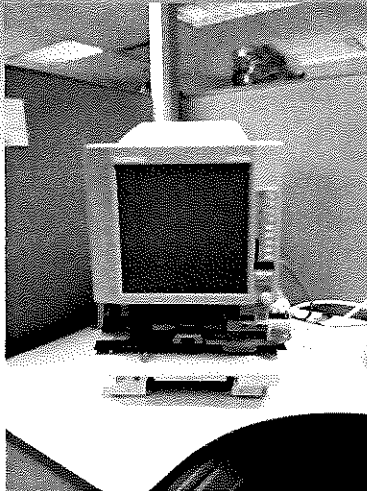
Building & Zoning

Date:

Aug 8, 2019

004

Micro film, printers, chairs

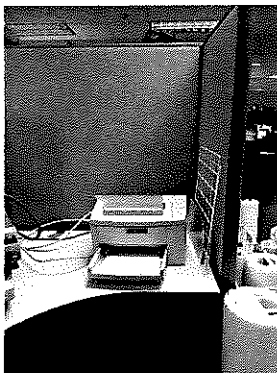


Select Item Type

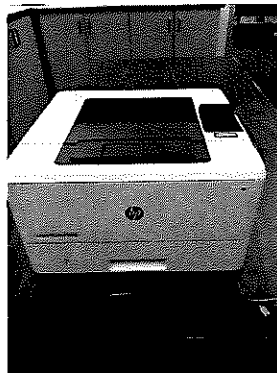
Lot of Multiple Items

Qty	Brand	Model	Working Condition Y/N	Description
1	Bell & Howell	ABR2400	N	MICRO-FILM
1	Bell & Howell	ABR2400	Y	MICRO-FILM PRINTER
1	HP	Laser Jet	Y	LASER JET PRO M402n
2			y	CHAIRS

Additional Comments



(Click above to add additional picture)



(Click above to add additional picture)



(Click above to add additional picture)

Name: ANNA HELTON

Title: OFFICE ADMIN

Phone Number 513-695-1295

Location of Item: BUILDING/ZONING DEPARTMENT

IMPORTANT: Please print this form off and tape it to the item(s) you are listing (excluding vehicles).
Check your listing for accuracy, click the button below to submit by email. *Note: This is the only way auction items will be accepted.*

Warren County Facilities Management

GovDeals #

BOE19011

430 South East Street
513-695-1463

Michael D. Shadoan
Director

GovDeals Item Inspection Form

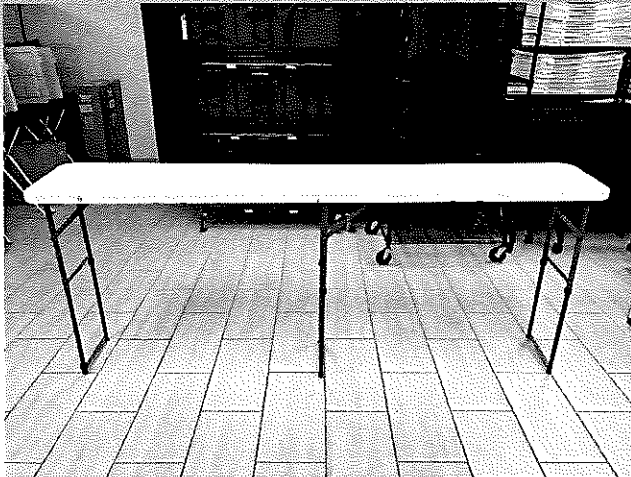
Board of Elections

Date:

Aug 5, 2019

011

40- 8 Foot Folding Tables



Select Item Type

Single Item

Category

Office Equipment/Supplies

Brand

Model #

Serial #

Date Removed From Service

8/5/19

Did Item Work When Removed?

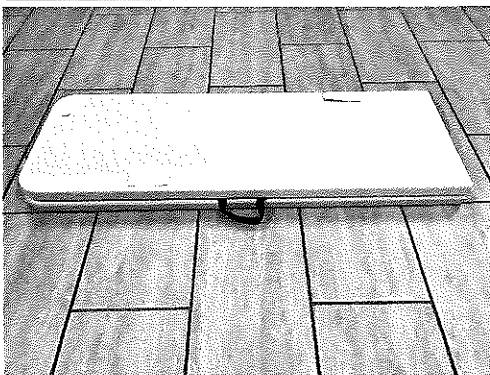
Yes

No

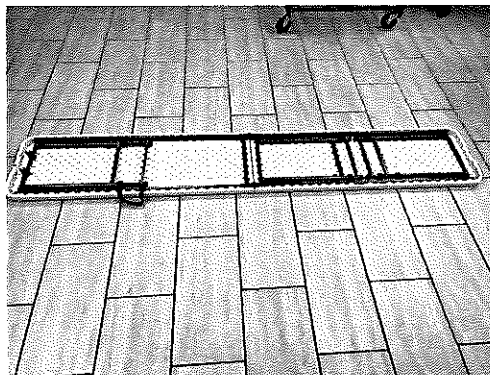
Unknown

Additional Comments

Lot of 40- 8 foot folding tables with extendable legs. Most tables have several pieces of Velcro Strips on the tops. Tables have been used for years and some have small dents and scratches. All tables are usable.



(Click above to add additional picture)



(Click above to add additional picture)

(Click above to add additional picture)

Name: Brian Sleeth

Title: Director

Phone Number x2682

Location of Item: Board of Elections

IMPORTANT: Please print this form off and tape it to the item(s) you are listing (excluding vehicles).
Check your listing for accuracy, click the button below to submit by email. Note: This is the only way auction items will be accepted.

Warren County Facilities Management

GovDeals #

DOM19015

430 South East Street
513-695-1463

Michael D. Shadoan
Director

GovDeals Item Inspection Form

Common Pleas Court - Domestic Relations

Date:

Aug 1, 2019

015

Chairs



Select Item Type

Lot of Multiple Items

Qty	Brand	Model	Working Condition Y/N	Description
12				Green Chairs

Additional Comments

(Click above to add additional picture)

(Click above to add additional picture)

(Click above to add additional picture)

Name: Deborah Grubb

Title: Judicial Assistant

Phone Number 513-695-2487

Location of Item: Common Pleas Building

IMPORTANT: Please print this form off and tape it to the item(s) you are listing (excluding vehicles).
Check your listing for accuracy, click the button below to submit by email. *Note: This is the only way auction items will be accepted.*

Warren County Facilities Management

GovDeals #

DTF19001

430 South East Street
513-695-1463

Michael D. Shadoan
Director

GovDeals Item Inspection Form

Drug Task Force

Date:

Aug 7, 2019

001

Monitor, Computer, & Scanner

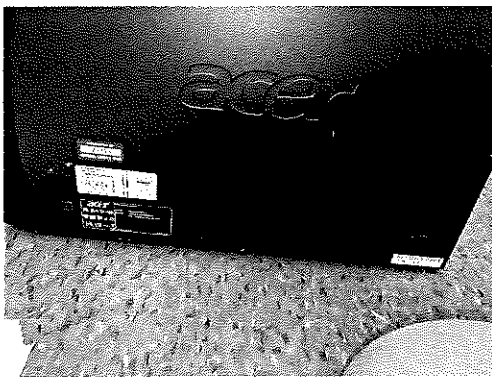


Select Item Type

Lot of Multiple Items

Qty	Brand	Model	Working Condition Y/N	Description
1	Cannon	DR-7580	N	Scanner, unknown condition, missing parts or accessories.
1	Asus		N	Monitor, unknown condition, missing parts or accessories.
1	Acer	M421G	N	Computer, unknown condition, missing parts or accessories.

Additional Comments



(Click above to add additional picture)



(Click above to add additional picture)

(Click above to add additional picture)

Name: Kathleen Farmer

Title: Computer Technician

Phone Number 513-695-1749

Location of Item: Warren County Sheriff's Office IT Hallway.

IMPORTANT: Please print this form off and tape it to the item(s) you are listing (excluding vehicles).
Check your listing for accuracy, click the button below to submit by email. *Note: This is the only way auction items will be accepted.*

Warren County Facilities Management

GovDeals #

FAC19041

430 South East Street
513-695-1463

Michael D. Shadoan
Director

GovDeals Item Inspection Form

Facilities Management

Date:

Aug 13, 2019

041

UPHOLSTERY CLOTH MATERIAL

Select Item Type

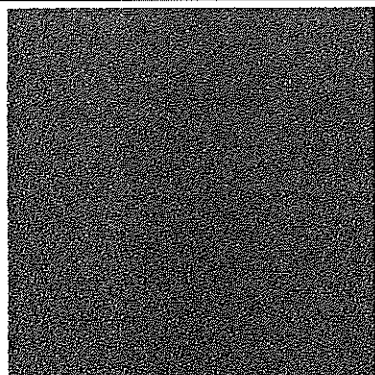
Lot of Multiple Items

Qty	Brand	Model	Working Condition Y/N	Description
1	MOMENTUM			LATTE HUE
1	MOMENTUM			ORIGIN CARAWAY

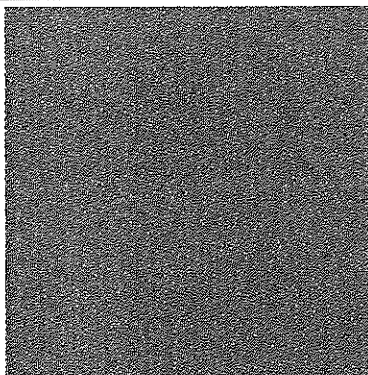
Additional Comments

MOMENTUM TEXTILES

PATTERN: HUE, COLOR: LATTE, BACKING: TEFLON, DURABILITY: 1,000,000 D.R., APPLICATION: UPHOLSTERY CLOTH. APPROXIMENT 2 YARDS OF MATERIALS.
PATTERN: ORIGIN, COLOR: CARAWAY, CONTENT: 100% POLYESTER, BACKING: ACRYLIC, DURABILITY: 282,000 D.R., APPLICATION: UPHOLSTERY. APPROXIMENT 1 YARD OF MATERIAL



(Click above to add additional picture)



(Click above to add additional picture)

(Click above to add additional picture)

Name: SAM ROBERTS

Title: ASSOCIATE ARCHITECT

Phone Number 695-3125

Location of Item: OFFICE 430 JUSTICE DRIVE, LEBANON, OHIO 457036

IMPORTANT: Please print this form off and tape it to the item(s) you are listing (excluding vehicles).
Check your listing for accuracy, click the button below to submit by email. Note: This is the only way auction items will be accepted.

430 South East Street
513-695-1463

Michael D. Shadoan
Director

GovDeals Item Inspection Form

Juvenile

Date:

Aug 4, 2019

007

Printer Stand and Typewriter Stand



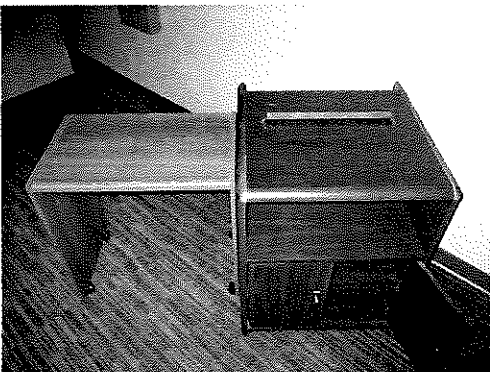
Select Item Type

Lot of Multiple Items

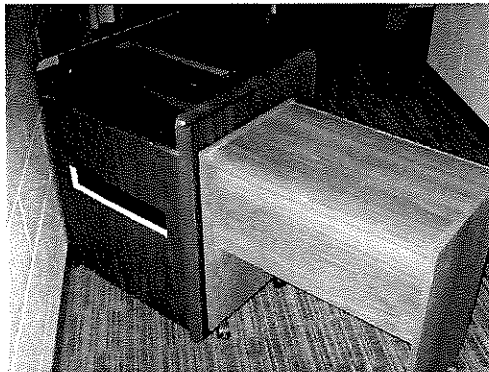
Qty	Brand	Model	Working Condition Y/N	Description
1			Y	Printer Stand
1			Y	Typewriter Stand

Additional Comments

Printer Stand 24" X 24" X 32" Lower section has two door closure with one shelf inside / Typewriter Stand 25" X 16" X 26" and on wheels / Both items show signs of wear



(Click above to add additional picture)



(Click above to add additional picture)

(Click above to add additional picture)

Name: Stephen Johnson

Title: Corrections Officer

Phone Number (513) 695-1392

Location of Item: Juvenile Storage - Silver Street Annex

IMPORTANT: Please print this form off and tape it to the item(s) you are listing (excluding vehicles).
Check your listing for accuracy, click the button below to submit by email. Note: This is the only way auction items will be accepted.

Warren County Facilities Management

GovDeals #

JUV19008

430 South East Street
513-695-1463

Michael D. Shadoan
Director

GovDeals Item Inspection Form

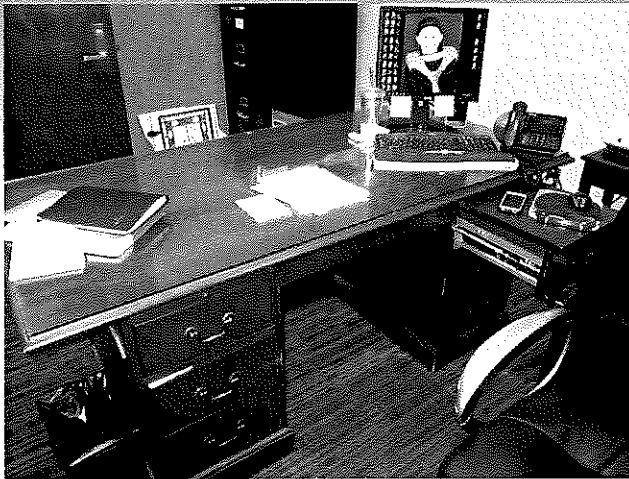
Juvenile

Date:

Aug 6, 2019

008

Office Desk



Select Item Type

Single Item

Category

Office Equipment/Supplies

Brand

Model #

Serial #

Date Removed From Service

8/6/19

Did Item Work When Removed?

Yes

No

Unknown

Additional Comments

Desk Only - Walnut Colored 70" X 36" - Very heavy and solid



(Click above to add additional picture)

(Click above to add additional picture)

(Click above to add additional picture)

Name: Stephen Johnson

Title: Corrections Officer

Phone Number (513) 695-1392

Location of Item: Administration Building Storage

IMPORTANT: Please print this form off and tape it to the item(s) you are listing (excluding vehicles).
Check your listing for accuracy, click the button below to submit by email. *Note: This is the only way auction items will be accepted.*

430 South East Street
513-695-1463

Michael D. Shadoan
Director

GovDeals Item Inspection Form

Juvenile

Date:

Aug 6, 2019

009

(2) Blue Leather? Chairs



Select Item Type

Single Item

Category

Office Equipment/Supplies

Brand

Model #

Serial #

Date Removed From Service

8/6/19

Did Item Work When Removed?

Yes

No

Unknown

Additional Comments

(2) Blue Office Chairs - Leather (not positive) - Some wear and marks, but usable



(Click above to add additional picture)



(Click above to add additional picture)

(Click above to add additional picture)

Name: Stephen Johnson

Title: Corrections Officer

Phone Number (513) 695-1392

Location of Item: Juvenile Storage - Silver Street Annex

IMPORTANT: Please print this form off and tape it to the item(s) you are listing (excluding vehicles).
Check your listing for accuracy, click the button below to submit by email. *Note: This is the only way auction items will be accepted.*

Warren County Facilities Management

GovDeals #

JUV19010

430 South East Street
513-695-1463

Michael D. Shadoan
Director

GovDeals Item Inspection Form

Juvenile

Date:

Aug 13, 2019

010

Intoxilyzer



Select Item Type

Single Item

Category

Laboratory Equipment

Brand

CMI

Model #

500

Serial #

74320

Date Removed From Service

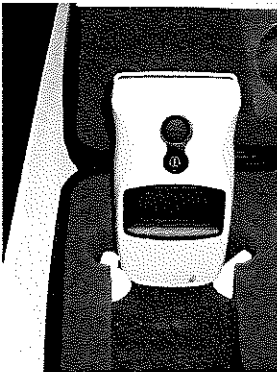
8/12/19

Did Item Work When Removed?

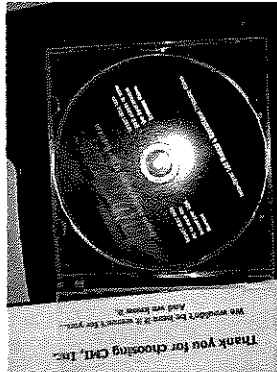
 Yes No Unknown

Additional Comments

The machine is difficult to calibrate and needs the fuel cell replaced according to the manufacturer. All paperwork and training DVD included.



(Click above to add additional picture)



(Click above to add additional picture)



(Click above to add additional picture)

Name: Stephen Johnson

Title: Corrections Officer

Phone Number (513) 695-1392

Location of Item: Juvenile Storage - Silver Street Annex

IMPORTANT: Please print this form off and tape it to the item(s) you are listing (excluding vehicles).
Check your listing for accuracy, click the button below to submit by email. *Note: This is the only way auction items will be accepted.*

Warren County Facilities Management

GovDeals #

SHF19001

430 South East Street
513-695-1463

Michael D. Shadoan
Director

GovDeals Item Inspection Form

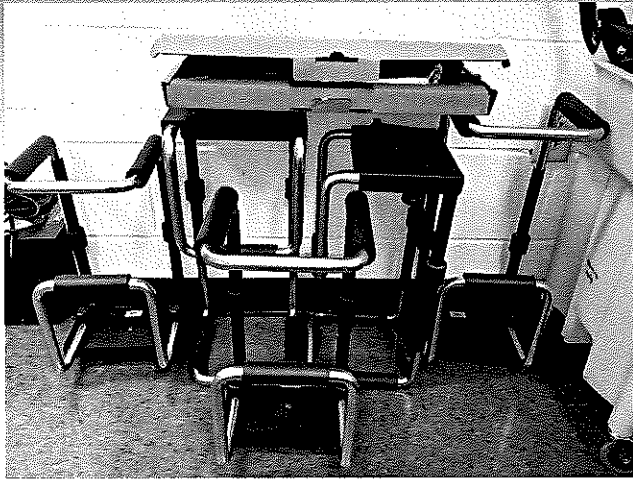
Sheriff

Date:

Aug 7, 2019

001

5 Computer Tower Mounts

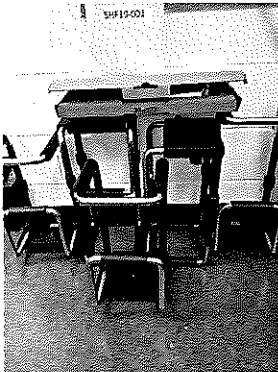


Select Item Type

Lot of Multiple Items

Qty	Brand	Model	Working Condition Y/N	Description
5			N	Computer Tower Mounts, unknown condition, missing parts or accessories.

Additional Comments



(Click above to add additional picture)



(Click above to add additional picture)

(Click above to add additional picture)

Name: Kathleen Farmer

Title: Computer Technician

Phone Number 513-695-1749

Location of Item: Warren County Sheriff's Office IT Hallway.

IMPORTANT: Please print this form off and tape it to the item(s) you are listing (excluding vehicles).
Check your listing for accuracy, click the button below to submit by email. *Note: This is the only way auction items will be accepted.*

Warren County Facilities Management

GovDeals #

SHF19002

430 South East Street
513-695-1463

Michael D. Shadoan
Director

GovDeals Item Inspection Form

Sheriff

Date:

Aug 7, 2019

002

5 Printers

Select Item Type

Lot of Multiple Items



Qty	Brand	Model	Working Condition Y/N	Description
2	HP	CP2025	N	Printers, unknown condition, missing parts or accessories.
3	HP	M451DN	N	Printers, unknown condition, missing parts or accessories.

Additional Comments



(Click above to add additional picture)



(Click above to add additional picture)

(Click above to add additional picture)

Name: Kathleen Farmer

Title: Computer Technician

Phone Number 513-695-1749

Location of Item: Warren County Sheriff's Office IT Hallway.

IMPORTANT: Please print this form off and tape it to the item(s) you are listing (excluding vehicles).
Check your listing for accuracy, click the button below to submit by email. *Note: This is the only way auction items will be accepted.*

Warren County Facilities Management

GovDeals #

SHF19003

430 South East Street
513-695-1463

Michael D. Shadoan
Director

GovDeals Item Inspection Form

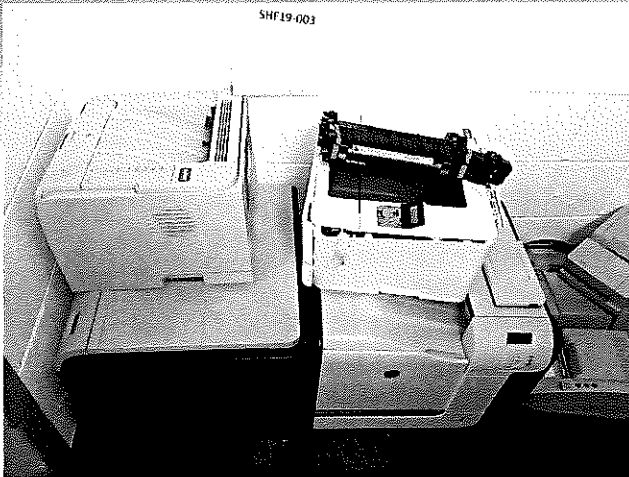
Sheriff

Date:

Aug 7, 2019

003

4 Printers

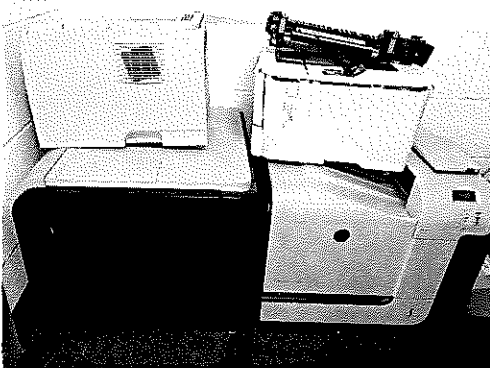


Select Item Type

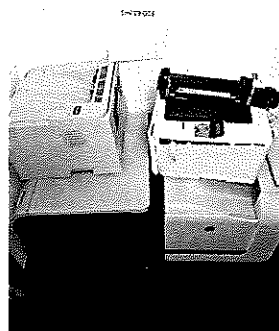
Lot of Multiple Items

Qty	Brand	Model	Working Condition Y/N	Description
2	HP	M551	N	Printers, unknown condition, missing parts or accessories.
1	HP	M402DN	N	Printers, unknown condition, missing parts or accessories.
1	HP	P2035	N	Printers, unknown condition, missing parts or accessories.

Additional Comments



(Click above to add additional picture)



(Click above to add additional picture)

(Click above to add additional picture)

Name: Kathleen Farmer

Title: Computer Technician

Phone Number 513-695-1749

Location of Item: Warren County Sheriff's Office IT Hallway.

IMPORTANT: Please print this form off and tape it to the item(s) you are listing (excluding vehicles).
Check your listing for accuracy, click the button below to submit by email. *Note: This is the only way auction items will be accepted.*

430 South East Street
513-695-1463

Michael D. Shadoan
Director

GovDeals Item Inspection Form

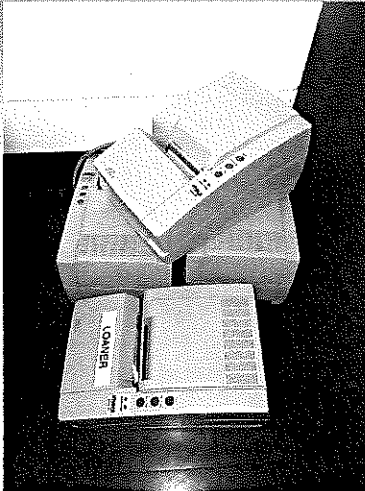
Sheriff

Date:

Aug 7, 2019

004

4 Receipt Printers

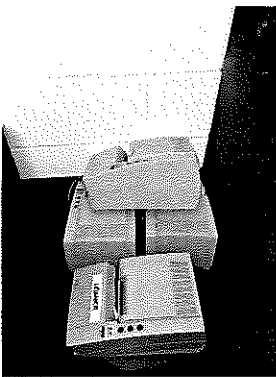


Select Item Type

Lot of Multiple Items

Qty	Brand	Model	Working Condition Y/N	Description
4	thica	90Plus	N	Receipt printers, unknown condition, missing parts or accessories.

Additional Comments



(Click above to add additional picture)



(Click above to add additional picture)

(Click above to add additional picture)

Name: Kathleen Farmer

Title: Computer Technician

Phone Number 513-695-1749

Location of Item: Warren County Sheriff's Office IT Hallway.

IMPORTANT: Please print this form off and tape it to the item(s) you are listing (excluding vehicles).
Check your listing for accuracy, click the button below to submit by email. *Note: This is the only way auction items will be accepted.*

430 South East Street
513-695-1463

Michael D. Shadoan
Director

GovDeals Item Inspection Form

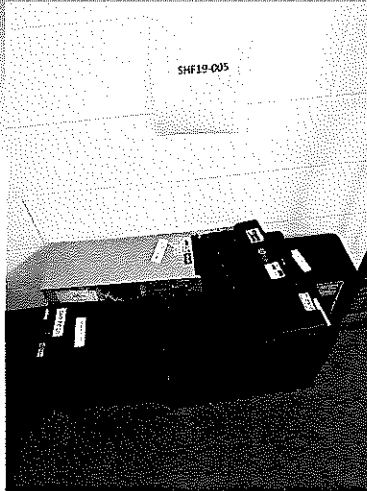
Sheriff

Date:

Aug 7, 2019

005

5 Computers and 1 Laptop Dock



Select Item Type

Lot of Multiple Items

Qty	Brand	Model	Working Condition Y/N	Description
1	HP	Pumba 1.0	N	Laptop Dock, unknown condition, missing parts or accessories.
1	HP	Probook	N	Laptop, unknown condition, missing parts or accessories.
1	HP	XW4600	N	Computer, unknown condition, missing parts or accessories
1	Dell		N	Computer, unknown condition, missing parts or accessories
1	Acer	M421G	N	Computer, unknown condition, missing parts or accessories
1	HP	400G3	N	Computer, unknown condition, missing parts or accessories

Additional Comments



(Click above to add additional picture)



(Click above to add additional picture)

(Click above to add additional picture)

Name: Kathleen Farmer

Title: Computer Technician

Phone Number 513-695-1749

Location of Item: Warren County Sheriff's Office IT Hallway.

IMPORTANT: Please print this form off and tape it to the item(s) you are listing (excluding vehicles).
Check your listing for accuracy, click the button below to submit by email. *Note: This is the only way auction items will be accepted.*

Warren County Facilities Management

GovDeals

WAT19010

430 South East Street
513-695-1463

Michael D. Shadoan
Director

GovDeals Item Inspection Form

Water & Sewer - Water

Date:

Aug 2, 2019

010

KUNDEL SHORELITE TRENCH BOX



Select Item Type

Single Item

Category

Public Utility Equipment

Brand

KUNDEL SHORELITE

Model #

Serial #

Date Removed From Service

JANUARY 1, 2019

Did Item Work When Removed?

Yes

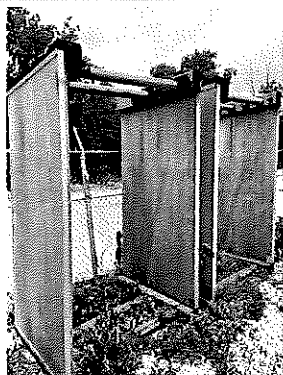
No

Unknown

Additional Comments

KUNDEL SHORELITE TRENCH BOX OSHA

(29CFR PART 926.650-652 SUBPART P) 4 FOOT TALL 8 FOOT LONG



(Click above to add additional picture)



(Click above to add additional picture)

(Click above to add additional picture)

Name: Amy Hensley

Title: Admin Asst

Phone Number 513 695 2307

Location of Item: 1200 Monroe Rd, Lebanon, Ohio 45036

IMPORTANT: Please print this form off and tape it to the item(s) you are listing (excluding vehicles).
Check your listing for accuracy, click the button below to submit by email. *Note: This is the only way auction items will be accepted.*

Warren County Facilities Management

GovDeals #

WAT19011

430 South East Street
513-695-1463

Michael D. Shadoan
Director

GovDeals Item Inspection Form

Water & Sewer - Water

Date:

Aug 2, 2019

011

2008 F-250 SUPER DUTY



Select Item Type

Vehicle

Vin #

1FTSX21548ED63605

Title restriction?

Yes No

Odometer Reading

165900

Yes

Accurate?

No Unknown

Year

2008

Make

FORD

Model

F-250

Does it Start?

Yes No With Boost

Does it run?

Yes No

Color

WHITE

Exterior Condition?

Good Minor Dents, Dings
Scratches or rust

Severe dents, Dings
Scratches or Rust

Interior

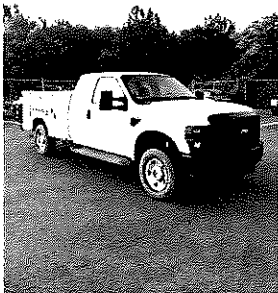
Cloth Leather Other

Interior Condition?

Good Fair Poor

Additional Comments

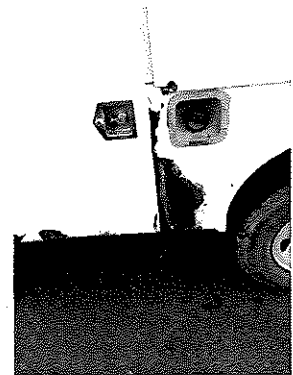
2008 F-250 SUPER DUTY. 5.4L V8 GASOLINE ENGINE AUTOMATIC TRANSMISSION. MANUAL LOCKS AND WINDOWS. SEVERE RUST ON CAB AND TRUCK SERVICE BODY. VEHICLE HAS NOT BEEN IN OUR DEPARTMENT FOR A WHILE SO CONDITION IS UNKNOWN. ONE KNOWN CONCERN IS THAT THE PARKING BRAKE FAILED.



(Click above to add additional picture)



(Click above to add additional picture)



(Click above to add additional picture)

Name: AMY HENSLEY

Title: ADMIN ASST

Phone Number 513 695 2307

Location of Item: 1433 WEST MAIN STREET LEBANON OHIO 45036. WARREN COUNTY GARAGE

IMPORTANT: Please print this form off and tape it to the item(s) you are listing (excluding vehicles).
Check your listing for accuracy, click the button below to submit by email. Note: This is the only way auction items will be accepted.

Warren County Facilities Management

GovDeals #

WAT19012

430 South East Street
513-695-1463

Michael D. Shadoan
Director

GovDeals Item Inspection Form

Water & Sewer - Water

Date:

Aug 2, 2019

012

2006 FORD F-550



Select Item Type

Vehicle

Vin #

1FDAF57Y27EA14020

Title restriction?

Yes No

Odometer Reading

128555

Yes

Accurate?

No Unknown

Year

2006

Make

FORD

Model

F-550

Does it Start?

Yes No With Boost

Does it run?

Yes No

Color

WHITE

Exterior Condition?

Good Minor Dents, Dings
Scratches or rust Sever dents, Dings
Scratches or Rust

Interior

Cloth Leather Other

Interior Condition?

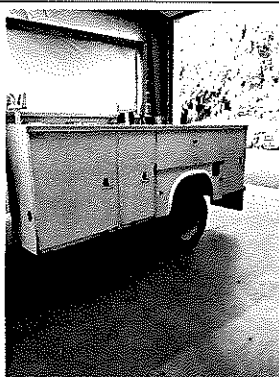
Good Fair Poor

Additional Comments

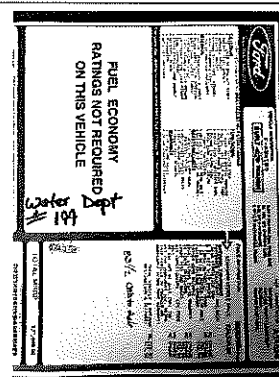
2006 FORD F-550 SUPER DUTY. 6.8L V10 GASOLINE ENGINE, AUTOMATIC TRANSMISSION. STARTS WITH A JUMP. A/C, STOCK AM/FM RADIO, POWER STEERING. NO POWER OPTIONS MANUAL WINDOWS, LOCKS, SEATS, MIRRORS. REMOVED FROM SERVICE DUE TO HIGH MILAGE AND OVERALL CONDITION.



(Click above to add additional picture)



(Click above to add additional picture)



(Click above to add additional picture)

Name: AMY HENSLEY

Title: ADMIN ASST

Phone Number 513 695 2307

Location of Item: 1433 WEST MAIN STREET LEBANON OHIO 45036. WARREN COUNTY GARAGE.

IMPORTANT: Please print this form off and tape it to the item(s) you are listing (excluding vehicles).
Check your listing for accuracy, click the button below to submit by email. Note: This is the only way auction items will be accepted.

Resolution

Number 19-1075

Adopted Date August 20, 2019

APPROVE AND AUTHORIZE THE COUNTY ADMINISTRATOR TO SIGN A GRANT AGREEMENT BY AND BETWEEN THE FEDERAL AVIATION ADMINISTRATION AND THE WARREN COUNTY BOARD OF COMMISSIONERS RELATIVE TO THE WARREN COUNTY/JOHN LANE FIELD AIRPORT

BE IT RESOLVED, to approve and authorize the President of the Board to sign a grant agreement with the Federal Aviation Administration for the replacement of 4-box PAPI on Runway 1 and 19 at the Warren County/John Lane Field Airport, as attached hereto and made a part hereof.

Mr. Young moved for adoption of the foregoing resolution being seconded by Mr. Grossmann. Upon call of the roll, the following vote resulted:

Mrs. Jones – yea
Mr. Grossmann – yea
Mr. Young – yea

Resolution adopted this 20th day of August 2019.

BOARD OF COUNTY COMMISSIONERS


Tina Osborne, Clerk

/to

cc: Airport Authority (file) (Al Wolfson)
Tiffany Zindel
C/A—FAA
FAA
OGA

This Offer is made on and **SUBJECT TO THE FOLLOWING TERMS AND CONDITIONS:**

CONDITIONS

1. **Maximum Obligation.** The maximum obligation of the United States payable under this Offer is \$126,544. The following amounts represent a breakdown of the maximum obligation for the purpose of establishing allowable amounts for any future grant amendment, which may increase the foregoing maximum obligation of the United States under the provisions of 49 U.S.C. § 47108(b):
 - \$0 for planning
 - \$126,544 airport development or noise program implementation; and,
 - \$0 for land acquisition.
2. **Period of Performance.** The period of performance begins on the date the Sponsor formally accepts this agreement. Unless explicitly stated otherwise in an amendment from the FAA, the end date of the period of performance is 4 years (1,460 calendar days) from the date of formal grant acceptance by the Sponsor. The Sponsor may only charge allowable costs for obligations incurred prior to the end date of the period of performance (2 CFR §200.309). Unless the FAA authorizes a written extension, the sponsor must submit all project closeout documentation and liquidate (pay off) all obligations incurred under this award no later than 90 calendar days after the end date of the period of performance (2 CFR §200.343). The period of performance end date does not relieve or reduce Sponsor obligations and assurances that extend beyond the closeout of a grant agreement.
3. **Ineligible or Unallowable Costs.** The Sponsor must not include any costs in the project that the FAA has determined to be ineligible or unallowable.
4. **Indirect Costs - Sponsor.** Sponsor may charge indirect costs under this award by applying the indirect cost rate identified in the project application as accepted by the FAA, to allowable costs for Sponsor direct salaries and wages.
5. **Determining the Final Federal Share of Costs.** The United States' share of allowable project costs will be made in accordance with the regulations, policies, and procedures of the Secretary. Final determination of the United States' share will be based upon the final audit of the total amount of allowable project costs and settlement will be made for any upward or downward adjustments to the Federal share of costs.
6. **Completing the Project Without Delay and in Conformance with Requirements.** The Sponsor must carry out and complete the project without undue delays and in accordance with this agreement, and the regulations, policies, and procedures of the Secretary. Per 2 CFR § 200.308, the Sponsor agrees to report to the FAA any disengagement from performing the project that exceeds three months. The report must include a reason for the project stoppage. The Sponsor also agrees to comply with the assurances which are part of this agreement.
7. **Amendments or Withdrawals before Grant Acceptance.** The FAA reserves the right to amend or withdraw this offer at any time prior to its acceptance by the Sponsor.
8. **Offer Expiration Date.** This offer will expire and the United States will not be obligated to pay any part of the costs of the project unless this offer has been accepted by the Sponsor on or before August 28, 2019, or such subsequent date as may be prescribed in writing by the FAA.
9. **Improper Use of Federal Funds.** The Sponsor must take all steps, including litigation if necessary, to recover Federal funds spent fraudulently, wastefully, or in violation of Federal antitrust statutes, or misused in any other manner for any project upon which Federal funds have been expended. For the purposes of this grant agreement, the term "Federal funds" means funds however used or dispersed by the Sponsor, that were originally paid pursuant to this or any other Federal grant agreement. The Sponsor must obtain the approval of the Secretary as to any determination of the amount of the Federal share of

United States to be used for any project for which funds are provided under this grant. The Sponsor will include a provision implementing Buy American in every contract.

- 17. Maximum Obligation Increase For Nonprimary Airports.** In accordance with 49 U.S.C. § 47108(b), as amended, the maximum obligation of the United States, as stated in Condition No. 1 of this Grant Offer:
- A. May not be increased for a planning project;
 - B. May be increased by not more than 15 percent for development projects;
 - C. May be increased by not more than 15 percent or by an amount not to exceed 25 percent of the total increase in allowable costs attributable to the acquisition of land or interests in land, whichever is greater, based on current credible appraisals or a court award in a condemnation proceeding.
- 18. Audits for Public Sponsors.** The Sponsor must provide for a Single Audit or program specific audit in accordance with 2 CFR part 200. The Sponsor must submit the audit reporting package to the Federal Audit Clearinghouse on the Federal Audit Clearinghouse's Internet Data Entry System at <http://harvester.census.gov/facweb/>. Provide one copy of the completed audit to the FAA if requested.
- 19. Suspension or Debarment.** When entering into a "covered transaction" as defined by 2 CFR §180.200, the Sponsor must:
- A. Verify the non-federal entity is eligible to participate in this Federal program by:
 1. Checking the excluded parties list system (EPLS) as maintained within the System for Award Management (SAM) to determine if the non-federal entity is excluded or disqualified; or
 2. Collecting a certification statement from the non-federal entity attesting they are not excluded or disqualified from participating; or
 3. Adding a clause or condition to covered transactions attesting individual or firm are not excluded or disqualified from participating.
 - B. Require prime contractors to comply with 2 CFR §180.330 when entering into lower-tier transactions (e.g. Sub-contracts).
 - C. Immediately disclose to the FAA whenever the Sponsor (1) learns they have entered into a covered transaction with an ineligible entity or (2) suspends or debar a contractor, person, or entity.
- 20. Ban on Texting While Driving.**
- A. In accordance with Executive Order 13513, Federal Leadership on Reducing Text Messaging While Driving, October 1, 2009, and DOT Order 3902.10, Text Messaging While Driving, December 30, 2009, the Sponsor is encouraged to:
 1. Adopt and enforce workplace safety policies to decrease crashes caused by distracted drivers including policies to ban text messaging while driving when performing any work for, or on behalf of, the Federal government, including work relating to a grant or subgrant.
 2. Conduct workplace safety initiatives in a manner commensurate with the size of the business, such as:
 - a. Establishment of new rules and programs or re-evaluation of existing programs to prohibit text messaging while driving; and
 - b. Education, awareness, and other outreach to employees about the safety risks associated with texting while driving.
 - B. The Sponsor must insert the substance of this clause on banning texting while driving in all subgrants, contracts and subcontracts.

offer of this grant, the existing assurances are attached herein; however, FAA shall interpret and apply these assurances consistent with the Reauthorization Act. To the extent there is a conflict between the assurances and Federal statutes, the statutes shall apply. The full text of the Act is at <https://www.congress.gov/bill/115th-congress/house-bill/302/text>.

25. **Co-Sponsor.** The Co-Sponsors understand and agree that they jointly and severally adopt and ratify the representations and assurances contained therein and that the word "Sponsor" as used in the application and other assurances is deemed to include all co-sponsors.

SPECIAL CONDITIONS

26. **Environmental.** The environmental approval for this project was issued on 2/15/2019.
27. **Plans and Specifications Approval Based Upon Certification.** The FAA and the Sponsor agree that the FAA approval of the Sponsor's Plans and Specification is based primarily upon the Sponsor's certification to carry out the project in accordance with policies, standards, and specifications approved by the FAA. The Sponsor understands that:
- A. The Sponsor's certification does not relieve the Sponsor of the requirement to obtain prior FAA approval for modifications to any AIP standards or to notify the FAA of any limitations to competition within the project;
 - B. The FAA's acceptance of a Sponsor's certification does not limit the FAA from reviewing appropriate project documentation for the purpose of validating the certification statements; and,
 - C. If the FAA determines that the Sponsor has not complied with their certification statements, the FAA will review the associated project costs to determine whether such costs are allowable under AIP.
28. **Airport - Owned Visual or Electronic Navigation Aids in Project.** The Sponsor agrees that it will:
- A. Provide for the continuous operation and maintenance of any navigational aid funded under this grant agreement during the useful life of the equipment;
 - B. Prior to commissioning, assure the equipment meets the FAA's standards; and
 - C. Remove, relocate, lower, mark, or light each obstruction to obtain a clear approach as indicated in the 14 CFR part 77 aeronautical survey.

PART II - ACCEPTANCE

The Sponsor does hereby ratify and adopt all assurances, statements, representations, warranties, covenants, and agreements contained in the Project Application and incorporated materials referred to in the foregoing Offer, and does hereby accept this Offer and by such acceptance agrees to comply with all of the terms and conditions in this Offer and in the Project Application.

I declare under penalty of perjury that the foregoing is true and correct.¹

Executed this 15 day of AUGUST, 2019.

[Handwritten signature]



**KIANA HAWK
NOTARY PUBLIC
STATE OF OHIO
Recorded in
Warren County
My Comm. Exp. 7/19/2023**

Warren County Airport Authority

[Handwritten signature]
(Name of Sponsor)

(Signature of Sponsor's Authorized Official)

By:

ALAN WOLFSON
(Typed Name of Sponsor's Authorized Official)

Title:

SECRETARY-TREASURER
(Title of Sponsor's Authorized Official)

CERTIFICATE OF SPONSOR'S ATTORNEY

I, Bruce A. McGary, Asst. Pros., acting as Attorney for the Sponsor do hereby certify:

That in my opinion the Sponsor is empowered to enter into the foregoing Grant Agreement under the laws of the State of Ohio. Further, I have examined the foregoing Grant Agreement and the actions taken by said Sponsor and Sponsor's official representative has been duly authorized and that the execution thereof is in all respects due and proper and in accordance with the laws of the said State and the Act. In addition, for grants involving projects to be carried out on property not owned by the Sponsor, there are no legal impediments that will prevent full performance by the Sponsor. Further, it is my opinion that the said Grant Agreement constitutes a legal and binding obligation of the Sponsor in accordance with the terms thereof.

Dated at Lebanon, OH (location) this 20th day of August, 2019

By: Bruce A. McGary, Asst. Pros.
(Signature of Sponsor's Attorney)

¹Knowingly and willfully providing false information to the Federal government is a violation of 18 U.S.C. Section 1001 (False Statements) and could subject you to fines, imprisonment, or both.

ASSURANCES

AIRPORT SPONSORS

A. General.

- a. These assurances shall be complied with in the performance of grant agreements for airport development, airport planning, and noise compatibility program grants for airport sponsors.
- b. These assurances are required to be submitted as part of the project application by sponsors requesting funds under the provisions of Title 49, U.S.C., subtitle VII, as amended. As used herein, the term "public agency sponsor" means a public agency with control of a public-use airport; the term "private sponsor" means a private owner of a public-use airport; and the term "sponsor" includes both public agency sponsors and private sponsors.
- c. Upon acceptance of this grant offer by the sponsor, these assurances are incorporated in and become part of this grant agreement.

B. Duration and Applicability.

1. Airport development or Noise Compatibility Program Projects Undertaken by a Public Agency Sponsor.

The terms, conditions and assurances of this grant agreement shall remain in full force and effect throughout the useful life of the facilities developed or equipment acquired for an airport development or noise compatibility program project, or throughout the useful life of the project items installed within a facility under a noise compatibility program project, but in any event not to exceed twenty (20) years from the date of acceptance of a grant offer of Federal funds for the project. However, there shall be no limit on the duration of the assurances regarding Exclusive Rights and Airport Revenue so long as the airport is used as an airport. There shall be no limit on the duration of the terms, conditions, and assurances with respect to real property acquired with federal funds. Furthermore, the duration of the Civil Rights assurance shall be specified in the assurances.

2. Airport Development or Noise Compatibility Projects Undertaken by a Private Sponsor.

The preceding paragraph 1 also applies to a private sponsor except that the useful life of project items installed within a facility or the useful life of the facilities developed or equipment acquired under an airport development or noise compatibility program project shall be no less than ten (10) years from the date of acceptance of Federal aid for the project.

3. Airport Planning Undertaken by a Sponsor.

Unless otherwise specified in this grant agreement, only Assurances 1, 2, 3, 5, 6, 13, 18, 25, 30, 32, 33, and 34 in Section C apply to planning projects. The terms, conditions, and assurances of this grant agreement shall remain in full force and effect during the life of the project; there shall be no limit on the duration of the assurances regarding Exclusive Rights and Airport Revenue so long as the airport is used as an airport.

C. Sponsor Certification.

The sponsor hereby assures and certifies, with respect to this grant that:

1. General Federal Requirements.

It will comply with all applicable Federal laws, regulations, executive orders, policies, guidelines, and requirements as they relate to the application, acceptance and use of Federal funds for this project including but not limited to the following:

- d. Executive Order 12372 - Intergovernmental Review of Federal Programs
- e. Executive Order 12699 - Seismic Safety of Federal and Federally Assisted New Building Construction¹
- f. Executive Order 12898 - Environmental Justice

FEDERAL REGULATIONS

- a. 2 CFR Part 180 - OMB Guidelines to Agencies on Governmentwide Debarment and Suspension (Nonprocurement).
- b. 2 CFR Part 200, Uniform Administrative Requirements, Cost Principles, and Audit Requirements for Federal Awards. [OMB Circular A-87 Cost Principles Applicable to Grants and Contracts with State and Local Governments, and OMB Circular A-133 - Audits of States, Local Governments, and Non-Profit Organizations].^{4,5,6}
- c. 2 CFR Part 1200 – Nonprocurement Suspension and Debarment
- d. 14 CFR Part 13 - Investigative and Enforcement Procedures 14 CFR Part 16 - Rules of Practice For Federally Assisted Airport Enforcement Proceedings.
- e. 14 CFR Part 150 - Airport noise compatibility planning.
- f. 28 CFR Part 35- Discrimination on the Basis of Disability in State and Local Government Services.
- g. 28 CFR § 50.3 - U.S. Department of Justice Guidelines for Enforcement of Title VI of the Civil Rights Act of 1964.
- h. 29 CFR Part 1 - Procedures for predetermination of wage rates.¹
- i. 29 CFR Part 3 - Contractors and subcontractors on public building or public work financed in whole or part by loans or grants from the United States.¹
- j. 29 CFR Part 5 - Labor standards provisions applicable to contracts covering federally financed and assisted construction (also labor standards provisions applicable to non-construction contracts subject to the Contract Work Hours and Safety Standards Act).¹
- k. 41 CFR Part 60 - Office of Federal Contract Compliance Programs, Equal Employment Opportunity, Department of Labor (Federal and federally assisted contracting requirements).¹
- l. 49 CFR Part 18 - Uniform administrative requirements for grants and cooperative agreements to state and local governments.³
- m. 49 CFR Part 20 - New restrictions on lobbying.
- n. 49 CFR Part 21 – Nondiscrimination in federally-assisted programs of the Department of Transportation - effectuation of Title VI of the Civil Rights Act of 1964.
- o. 49 CFR Part 23 - Participation by Disadvantage Business Enterprise in Airport Concessions.
- p. 49 CFR Part 24 – Uniform Relocation Assistance and Real Property Acquisition for Federal and Federally Assisted Programs.^{1,2}
- q. 49 CFR Part 26 – Participation by Disadvantaged Business Enterprises In Department of Transportation Programs.
- r. 49 CFR Part 27 – Nondiscrimination on the Basis of Handicap in Programs and Activities Receiving or Benefiting from Federal Financial Assistance.¹

It has legal authority to apply for this grant and to finance and carry out the proposed project and comply with all terms, conditions, and assurances of this grant agreement. It shall designate an official representative and shall in writing direct and authorize that person to file this application, including all understandings and assurances contained therein; to act in connection with this application; and to provide such additional information as may be required.

3. Sponsor Fund Availability.

It has sufficient funds available for that portion of the project costs which are not to be paid by the United States. It has sufficient funds available to assure operation and maintenance of items funded under this grant agreement which it will own or control.

4. Good Title.

- a. It, a public agency or the Federal government, holds good title, satisfactory to the Secretary, to the landing area of the airport or site thereof, or will give assurance satisfactory to the Secretary that good title will be acquired.
- b. For noise compatibility program projects to be carried out on the property of the sponsor, it holds good title satisfactory to the Secretary to that portion of the property upon which Federal funds will be expended or will give assurance to the Secretary that good title will be obtained.

5. Preserving Rights and Powers.

- a. It will not take or permit any action which would operate to deprive it of any of the rights and powers necessary to perform any or all of the terms, conditions, and assurances in this grant agreement without the written approval of the Secretary, and will act promptly to acquire, extinguish or modify any outstanding rights or claims of right of others which would interfere with such performance by the sponsor. This shall be done in a manner acceptable to the Secretary.
- b. It will not sell, lease, encumber, or otherwise transfer or dispose of any part of its title or other interests in the property shown on Exhibit A to this application or, for a noise compatibility program project, that portion of the property upon which Federal funds have been expended, for the duration of the terms, conditions, and assurances in this grant agreement without approval by the Secretary. If the transferee is found by the Secretary to be eligible under Title 49, United States Code, to assume the obligations of this grant agreement and to have the power, authority, and financial resources to carry out all such obligations, the sponsor shall insert in the contract or document transferring or disposing of the sponsor's interest, and make binding upon the transferee all of the terms, conditions, and assurances contained in this grant agreement.
- c. For all noise compatibility program projects which are to be carried out by another unit of local government or are on property owned by a unit of local government other than the sponsor, it will enter into an agreement with that government. Except as otherwise specified by the Secretary, that agreement shall obligate that government to the same terms, conditions, and assurances that would be applicable to it if it applied directly to the FAA for a grant to undertake the noise compatibility program project. That agreement and changes thereto must be satisfactory to the Secretary. It will take steps to enforce this agreement against the local government if there is substantial non-compliance with the terms of the agreement.

of the proposed amendment to the airport layout plan to depict the project and a copy of any airport master plan in which the project is described or depicted.

11. Pavement Preventive Maintenance.

With respect to a project approved after January 1, 1995, for the replacement or reconstruction of pavement at the airport, it assures or certifies that it has implemented an effective airport pavement maintenance-management program and it assures that it will use such program for the useful life of any pavement constructed, reconstructed or repaired with Federal financial assistance at the airport. It will provide such reports on pavement condition and pavement management programs as the Secretary determines may be useful.

12. Terminal Development Prerequisites.

For projects which include terminal development at a public use airport, as defined in Title 49, it has, on the date of submittal of the project grant application, all the safety equipment required for certification of such airport under section 44706 of Title 49, United States Code, and all the security equipment required by rule or regulation, and has provided for access to the passenger enplaning and deplaning area of such airport to passengers enplaning and deplaning from aircraft other than air carrier aircraft.

13. Accounting System, Audit, and Record Keeping Requirements.

- a. It shall keep all project accounts and records which fully disclose the amount and disposition by the recipient of the proceeds of this grant, the total cost of the project in connection with which this grant is given or used, and the amount or nature of that portion of the cost of the project supplied by other sources, and such other financial records pertinent to the project. The accounts and records shall be kept in accordance with an accounting system that will facilitate an effective audit in accordance with the Single Audit Act of 1984.
- b. It shall make available to the Secretary and the Comptroller General of the United States, or any of their duly authorized representatives, for the purpose of audit and examination, any books, documents, papers, and records of the recipient that are pertinent to this grant. The Secretary may require that an appropriate audit be conducted by a recipient. In any case in which an independent audit is made of the accounts of a sponsor relating to the disposition of the proceeds of a grant or relating to the project in connection with which this grant was given or used, it shall file a certified copy of such audit with the Comptroller General of the United States not later than six (6) months following the close of the fiscal year for which the audit was made.

14. Minimum Wage Rates.

It shall include, in all contracts in excess of \$2,000 for work on any projects funded under this grant agreement which involve labor, provisions establishing minimum rates of wages, to be predetermined by the Secretary of Labor, in accordance with the Davis-Bacon Act, as amended (40 U.S.C. 276a-276a-5), which contractors shall pay to skilled and unskilled labor, and such minimum rates shall be stated in the invitation for bids and shall be included in proposals or bids for the work.

15. Veteran's Preference.

It shall include in all contracts for work on any project funded under this grant agreement which involve labor, such provisions as are necessary to insure that, in the employment of labor (except in executive, administrative, and supervisory positions), preference shall be given to Vietnam era veterans, Persian Gulf veterans, Afghanistan-Iraq war veterans, disabled veterans, and small business concerns owned and controlled by disabled veterans as defined in Section 47112 of Title

required or prescribed by applicable Federal, state and local agencies for maintenance and operation. It will not cause or permit any activity or action thereon which would interfere with its use for airport purposes. It will suitably operate and maintain the airport and all facilities thereon or connected therewith, with due regard to climatic and flood conditions. Any proposal to temporarily close the airport for non-aeronautical purposes must first be approved by the Secretary. In furtherance of this assurance, the sponsor will have in effect arrangements for-

- 1) Operating the airport's aeronautical facilities whenever required;
 - 2) Promptly marking and lighting hazards resulting from airport conditions, including temporary conditions; and
 - 3) Promptly notifying airmen of any condition affecting aeronautical use of the airport. Nothing contained herein shall be construed to require that the airport be operated for aeronautical use during temporary periods when snow, flood or other climatic conditions interfere with such operation and maintenance. Further, nothing herein shall be construed as requiring the maintenance, repair, restoration, or replacement of any structure or facility which is substantially damaged or destroyed due to an act of God or other condition or circumstance beyond the control of the sponsor.
- b. It will suitably operate and maintain noise compatibility program items that it owns or controls upon which Federal funds have been expended.

20. Hazard Removal and Mitigation.

It will take appropriate action to assure that such terminal airspace as is required to protect instrument and visual operations to the airport (including established minimum flight altitudes) will be adequately cleared and protected by removing, lowering, relocating, marking, or lighting or otherwise mitigating existing airport hazards and by preventing the establishment or creation of future airport hazards.

21. Compatible Land Use.

It will take appropriate action, to the extent reasonable, including the adoption of zoning laws, to restrict the use of land adjacent to or in the immediate vicinity of the airport to activities and purposes compatible with normal airport operations, including landing and takeoff of aircraft. In addition, if the project is for noise compatibility program implementation, it will not cause or permit any change in land use, within its jurisdiction, that will reduce its compatibility, with respect to the airport, of the noise compatibility program measures upon which Federal funds have been expended.

22. Economic Nondiscrimination.

- a. It will make the airport available as an airport for public use on reasonable terms and without unjust discrimination to all types, kinds and classes of aeronautical activities, including commercial aeronautical activities offering services to the public at the airport.
- b. In any agreement, contract, lease, or other arrangement under which a right or privilege at the airport is granted to any person, firm, or corporation to conduct or to engage in any aeronautical activity for furnishing services to the public at the airport, the sponsor will insert and enforce provisions requiring the contractor to-
 - 1) furnish said services on a reasonable, and not unjustly discriminatory, basis to all users thereof, and
 - 2) charge reasonable, and not unjustly discriminatory, prices for each unit or service,

and sightseeing, aerial photography, crop dusting, aerial advertising and surveying, air carrier operations, aircraft sales and services, sale of aviation petroleum products whether or not conducted in conjunction with other aeronautical activity, repair and maintenance of aircraft, sale of aircraft parts, and any other activities which because of their direct relationship to the operation of aircraft can be regarded as an aeronautical activity, and that it will terminate any exclusive right to conduct an aeronautical activity now existing at such an airport before the grant of any assistance under Title 49, United States Code.

24. Fee and Rental Structure.

It will maintain a fee and rental structure for the facilities and services at the airport which will make the airport as self-sustaining as possible under the circumstances existing at the particular airport, taking into account such factors as the volume of traffic and economy of collection. No part of the Federal share of an airport development, airport planning or noise compatibility project for which a grant is made under Title 49, United States Code, the Airport and Airway Improvement Act of 1982, the Federal Airport Act or the Airport and Airway Development Act of 1970 shall be included in the rate basis in establishing fees, rates, and charges for users of that airport.

25. Airport Revenues.

- a. All revenues generated by the airport and any local taxes on aviation fuel established after December 30, 1987, will be expended by it for the capital or operating costs of the airport; the local airport system; or other local facilities which are owned or operated by the owner or operator of the airport and which are directly and substantially related to the actual air transportation of passengers or property; or for noise mitigation purposes on or off the airport. The following exceptions apply to this paragraph:
 - 1) If covenants or assurances in debt obligations issued before September 3, 1982, by the owner or operator of the airport, or provisions enacted before September 3, 1982, in governing statutes controlling the owner or operator's financing, provide for the use of the revenues from any of the airport owner or operator's facilities, including the airport, to support not only the airport but also the airport owner or operator's general debt obligations or other facilities, then this limitation on the use of all revenues generated by the airport (and, in the case of a public airport, local taxes on aviation fuel) shall not apply.
 - 2) If the Secretary approves the sale of a privately owned airport to a public sponsor and provides funding for any portion of the public sponsor's acquisition of land, this limitation on the use of all revenues generated by the sale shall not apply to certain proceeds from the sale. This is conditioned on repayment to the Secretary by the private owner of an amount equal to the remaining unamortized portion (amortized over a 20-year period) of any airport improvement grant made to the private owner for any purpose other than land acquisition on or after October 1, 1996, plus an amount equal to the federal share of the current fair market value of any land acquired with an airport improvement grant made to that airport on or after October 1, 1996.
 - 3) Certain revenue derived from or generated by mineral extraction, production, lease, or other means at a general aviation airport (as defined at Section 47102 of title 49 United States Code), if the FAA determines the airport sponsor meets the requirements set forth in Sec. 813 of Public Law 112-95.
 - a.) As part of the annual audit required under the Single Audit Act of 1984, the sponsor will direct that the audit will review, and the resulting audit report will provide an opinion concerning, the use of airport revenue and taxes in paragraph (a), and indicating whether funds paid or transferred to the owner or operator are paid or transferred in a

Federal expense of space or facilities for such purposes. Such areas or any portion thereof will be made available as provided herein within four months after receipt of a written request from the Secretary.

29. Airport Layout Plan.

- a. It will keep up to date at all times an airport layout plan of the airport showing:
- 1) boundaries of the airport and all proposed additions thereto, together with the boundaries of all offsite areas owned or controlled by the sponsor for airport purposes and proposed additions thereto;
 - 2) the location and nature of all existing and proposed airport facilities and structures (such as runways, taxiways, aprons, terminal buildings, hangars and roads), including all proposed extensions and reductions of existing airport facilities;
 - 3) the location of all existing and proposed nonaviation areas and of all existing improvements thereon; and
 - 4) all proposed and existing access points used to taxi aircraft across the airport's property boundary. Such airport layout plans and each amendment, revision, or modification thereof, shall be subject to the approval of the Secretary which approval shall be evidenced by the signature of a duly authorized representative of the Secretary on the face of the airport layout plan. The sponsor will not make or permit any changes or alterations in the airport or any of its facilities which are not in conformity with the airport layout plan as approved by the Secretary and which might, in the opinion of the Secretary, adversely affect the safety, utility or efficiency of the airport.
- a.) If a change or alteration in the airport or the facilities is made which the Secretary determines adversely affects the safety, utility, or efficiency of any federally owned, leased, or funded property on or off the airport and which is not in conformity with the airport layout plan as approved by the Secretary, the owner or operator will, if requested, by the Secretary (1) eliminate such adverse effect in a manner approved by the Secretary; or (2) bear all costs of relocating such property (or replacement thereof) to a site acceptable to the Secretary and all costs of restoring such property (or replacement thereof) to the level of safety, utility, efficiency, and cost of operation existing before the unapproved change in the airport or its facilities except in the case of a relocation or replacement of an existing airport facility due to a change in the Secretary's design standards beyond the control of the airport sponsor.

30. Civil Rights.

It will promptly take any measures necessary to ensure that no person in the United States shall, on the grounds of race, creed, color, national origin, sex, age, or disability be excluded from participation in, be denied the benefits of, or be otherwise subjected to discrimination in any activity conducted with, or benefiting from, funds received from this grant.

- a. Using the definitions of activity, facility and program as found and defined in §§ 21.23 (b) and 21.23 (e) of 49 CFR § 21, the sponsor will facilitate all programs, operate all facilities, or conduct all programs in compliance with all non-discrimination requirements imposed by, or pursuant to these assurances.
- b. Applicability
- 1) Programs and Activities. If the sponsor has received a grant (or other federal assistance) for any of the sponsor's program or activities, these requirements extend to all of the

- b.) For the construction or use of, or access to, space on, over, or under real property acquired or improved under the applicable activity, project, or program.
- f. It will provide for such methods of administration for the program as are found by the Secretary to give reasonable guarantee that it, other recipients, sub-recipients, sub-grantees, contractors, subcontractors, consultants, transferees, successors in interest, and other participants of Federal financial assistance under such program will comply with all requirements imposed or pursuant to the acts, the regulations, and this assurance.
- g. It agrees that the United States has a right to seek judicial enforcement with regard to any matter arising under the acts, the regulations, and this assurance.

3.1. Disposal of Land.

- a. For land purchased under a grant for airport noise compatibility purposes, including land serving as a noise buffer, it will dispose of the land, when the land is no longer needed for such purposes, at fair market value, at the earliest practicable time. That portion of the proceeds of such disposition which is proportionate to the United States' share of acquisition of such land will be, at the discretion of the Secretary, (1) reinvested in another project at the airport, or (2) transferred to another eligible airport as prescribed by the Secretary. The Secretary shall give preference to the following, in descending order, (1) reinvestment in an approved noise compatibility project, (2) reinvestment in an approved project that is eligible for grant funding under Section 47117(e) of title 49 United States Code, (3) reinvestment in an approved airport development project that is eligible for grant funding under Sections 47114, 47115, or 47117 of title 49 United States Code, (4) transferred to an eligible sponsor of another public airport to be reinvested in an approved noise compatibility project at that airport, and (5) paid to the Secretary for deposit in the Airport and Airway Trust Fund. If land acquired under a grant for noise compatibility purposes is leased at fair market value and consistent with noise buffering purposes, the lease will not be considered a disposal of the land. Revenues derived from such a lease may be used for an approved airport development project that would otherwise be eligible for grant funding or any permitted use of airport revenue.
- b. For land purchased under a grant for airport development purposes (other than noise compatibility), it will, when the land is no longer needed for airport purposes, dispose of such land at fair market value or make available to the Secretary an amount equal to the United States' proportionate share of the fair market value of the land. That portion of the proceeds of such disposition which is proportionate to the United States' share of the cost of acquisition of such land will, (1) upon application to the Secretary, be reinvested or transferred to another eligible airport as prescribed by the Secretary. The Secretary shall give preference to the following, in descending order: (1) reinvestment in an approved noise compatibility project, (2) reinvestment in an approved project that is eligible for grant funding under Section 47117(e) of title 49 United States Code, (3) reinvestment in an approved airport development project that is eligible for grant funding under Sections 47114, 47115, or 47117 of title 49 United States Code, (4) transferred to an eligible sponsor of another public airport to be reinvested in an approved noise compatibility project at that airport, and (5) paid to the Secretary for deposit in the Airport and Airway Trust Fund.
- c. Land shall be considered to be needed for airport purposes under this assurance if (1) it may be needed for aeronautical purposes (including runway protection zones) or serve as noise buffer land, and (2) the revenue from interim uses of such land contributes to the financial self-sufficiency of the airport. Further, land purchased with a grant received by an airport operator or owner before December 31, 1987, will be considered to be needed for airport purposes if the Secretary or Federal agency making such grant before December 31, 1987, was

nondiscrimination in the award and administration of DOT-assisted contracts, and/or concession contracts. The sponsor's DBE and ACDBE programs, as required by 49 CFR Parts 26 and 23, and as approved by DOT, are incorporated by reference in this agreement. Implementation of these programs is a legal obligation and failure to carry out its terms shall be treated as a violation of this agreement. Upon notification to the sponsor of its failure to carry out its approved program, the Department may impose sanctions as provided for under Parts 26 and 23 and may, in appropriate cases, refer the matter for enforcement under 18 U.S.C. 1001 and/or the Program Fraud Civil Remedies Act of 1936 (31 U.S.C. 3801).

38. Hangar Construction.

If the airport owner or operator and a person who owns an aircraft agree that a hangar is to be constructed at the airport for the aircraft at the aircraft owner's expense, the airport owner or operator will grant to the aircraft owner for the hangar a long term lease that is subject to such terms and conditions on the hangar as the airport owner or operator may impose.

39. Competitive Access.

- a. If the airport owner or operator of a medium or large hub airport (as defined in section 47102 of title 49, U.S.C.) has been unable to accommodate one or more requests by an air carrier for access to gates or other facilities at that airport in order to allow the air carrier to provide service to the airport or to expand service at the airport, the airport owner or operator shall transmit a report to the Secretary that-
 - 1) Describes the requests;
 - 2) Provides an explanation as to why the requests could not be accommodated; and
 - 3) Provides a time frame within which, if any, the airport will be able to accommodate the requests.
- b. Such report shall be due on either February 1 or August 1 of each year if the airport has been unable to accommodate the request(s) in the six month period prior to the applicable due date.

NUMBER	TITLE
150/5210-13C	Airport Water Rescue Plans and Equipment
150/5210-14B	Aircraft Rescue Fire Fighting Equipment, Tools and Clothing
150/5210-15A	Aircraft Rescue and Firefighting Station Building Design
150/5210-18A	Systems for Interactive Training of Airport Personnel
150/5210-19A	Driver's Enhanced Vision System (DEVIS)
150/5220-10E	Guide Specification for Aircraft Rescue and Fire Fighting (ARFF) Vehicles
150/5220-16E Changes 1	Automated Weather Observing Systems (AWOS) for Non-Federal Applications
150/5220-17B	Aircraft Rescue and Fire Fighting (ARFF) Training Facilities
150/5220-18A	Buildings for Storage and Maintenance of Airport Snow and Ice Control Equipment and Materials
150/5220-20A	Airport Snow and Ice Control Equipment
150/5220-21C	Aircraft Boarding Equipment
150/5220-22B	Engineered Materials Arresting Systems (EMAS) for Aircraft Overruns
150/5220-23	Frangible Connections
150/5220-24	Foreign Object Debris Detection Equipment
150/5220-25	Standard Airport Avian Radar Systems
150/5220-26 Changes 1-2	Airport Ground Vehicle Automatic Dependent Surveillance - Broadcast (ADS-B) Out Squitter Equipment
150/5300-13A Change 1	Airport Design
150/5300-14C	Design of Aircraft Deicing Facilities
150/5300-16A	General Guidance and Specifications for Aeronautical Surveys: Establishment of Geodetic Control and Submission to the National Geodetic Survey
150/5300-17C Change 1	Standards for Using Remote Sensing Technologies in Airport Surveys
150/5300-18B Change 1	General Guidance and Specifications for Submission of Aeronautical Surveys to NGS: Field Data Collection and Geographic Information System (GIS) Standards

NUMBER	TITLE
150/5345-44K	Specification for Runway and Taxiway Signs
150/5345-45C	Low-Impact Resistant (LIR) Structures
150/5345-46E	Specification for Runway and Taxiway Light Fixtures
150/5345-47C	Specification for Series to Series Isolation Transformers for Airport Lighting Systems
150/5345-49D	Specification L-854, Radio Control Equipment
150/5345-50B	Specification for Portable Runway and Taxiway Lights
150/5345-51B	Specification for Discharge-Type Flashing Light Equipment
150/5345-52A	Generic Visual Glideslope Indicators (GVGI)
150/5345-53D	Airport Lighting Equipment Certification Program
150/5345-54B	Specification for L-884, Power and Control Unit for Land and Hold Short Lighting Systems
150/5345-55A	Specification for L-893, Lighted Visual Aid to Indicate Temporary Runway Closure
150/5345-56B	Specification for L-890 Airport Lighting Control and Monitoring System (ALCMS)
150/5360-12F	Airport Signing and Graphics
150/5360-13A	Airport Terminal Planning
150/5360-14A	Access to Airports By Individuals With Disabilities
150/5370-2G	Operational Safety on Airports During Construction
150/5370-10H	Standards for Specifying Construction of Airports
150/5370-11B	Use of Nondestructive Testing in the Evaluation of Airport Pavements
150/5370-13A	Off-Peak Construction of Airport Pavements Using Hot-Mix Asphalt
150/5370-15B	Airside Applications for Artificial Turf
150/5370-16	Rapid Construction of Rigid (Portland Cement Concrete) Airfield Pavements
150/5370-17	Airside Use of Heated Pavement Systems
150/5390-2C	Heliport Design

THE FOLLOWING ADDITIONAL APPLY TO AIP PROJECTS ONLY

Updated: 3/22/2019

NUMBER	TITLE
150/5100-14E Change 1	Architectural, Engineering, and Planning Consultant Services for Airport Grant Projects
150/5100-17 Changes 1 - 7	Land Acquisition and Relocation Assistance for Airport Improvement Program Assisted Projects
150/5300-15A	Use of Value Engineering for Engineering Design of Airport Grant Projects
150/5320-17A	Airfield Pavement Surface Evaluation and Rating Manuals
150/5370-12B	Quality Management for Federally Funded Airport Construction Projects
150/5380-6C	Guidelines and Procedures for Maintenance of Airport Pavements
150/5380-7B	Airport Pavement Management Program
150/5380-9	Guidelines and Procedures for Measuring Airfield Pavement Roughness

Application for Federal Assistance SF-424

* 8. Type of Applicant 1: Select Applicant Type:

B: County Government

Type of Applicant 2: Select Applicant Type:

Type of Applicant 3: Select Applicant Type:

* Other (specify):

* 10. Name of Federal Agency:

Federal Aviation Administration

11. Catalog of Federal Domestic Assistance Number:

CFDA Title:

* 12. Funding Opportunity Number:

20.106

* Title:

Airport Improvement Program

13. Competition Identification Number:

Title

14. Areas Affected by Project (Cities, Counties, States, etc.):

Add Attachment

Delete Attachment

View Attachment

* 15. Descriptive Title of Applicant's Project:

Replace 4 box PAPI on Runway 1 and 19

Attach supporting documents as specified in agency instructions.

Add Attachments

Delete Attachments

View Attachments

**WARREN COUNTY AIRPORT-JOHN LAND FIELD
LEBANON, OHIO**

**FY2019 Improvements
Install New precision Approach Path Indicators (PAPI)**

<u>ITEM DESCRIPTION</u>	<u>COST</u>
ENGINEERING (Install PAPIs)	
Design	\$ 17,000.00
Bidding.....	\$ 4,500.00
Construction Administration.....	\$ 9,000.00
Construction and Materials Testing.....	\$ 1,000.00
Construction Observation	\$ 12,700.00
Government Applications.....	\$ 1,000.00
	\$ 45,200.00
CONSTRUCTION (Install PAPIs)	
Construction Total	\$ 81,600.00
FAA Eligible Total	\$ 81,600.00
SPONSOR PROJECT ADMINISTRATION COSTS	\$ 5,000.00
FLIGHT CHECK COST	\$ 8,804.00
TOTAL FAA ELIGIBLE PROJECT.....	\$ 140,604.00
FAA SHARE (90% - ELIGIBLE)	\$ 126,544.00
STATE (5% - ELIGIBLE).....	\$ 7,030.00
LOCAL SHARE (5% ELIGIBLE)	\$ 7,030.00
TOTAL	\$ 140,604.00



U.S. Department
of Transportation

Federal Aviation
Administration

FAA Form 5100-130, Drug-Free Workplace – Airport Improvement Program Sponsor Certification

Paperwork Reduction Act Burden Statement

A federal agency may not conduct or sponsor, and a person is not required to respond to, nor shall a person be subject to a penalty for failure to comply with a collection of information subject to the requirements of the Paperwork Reduction Act unless that collection of information displays a currently valid OMB Control Number. The OMB Control Number for this information collection is 2120-0569. Public reporting for this collection of information is estimated to be approximately 8 hours per response, including the time for reviewing instructions, searching existing data sources, gathering and maintaining the data needed, completing and reviewing the collection of information. All responses to this collection of information are required under 49 U.S.C. Section 47105 to retain a benefit and to meet the reporting requirements of 2 CFR 200. Send comments regarding this burden estimate or any other aspect of this collection of information, including suggestions for reducing this burden to the Federal Aviation Administration at: 800 Independence Ave. SW, Washington, DC 20591, Attn: Information Collection Clearance Officer, ASP-110.

3. Each employee to be engaged in the performance of the work has been or will be given a copy of the statement required within item 1 above prior to commencement of project (2 CFR § 182.210).

Yes No N/A

4. Employees have been or will be notified in the statement required by item 1 above that, as a condition employment under the grant (2 CFR § 182.205(c)), the employee will:

- a. Abide by the terms of the statement; and
- b. Notify the employer in writing of his or her conviction for a violation of a criminal drug statute occurring in the workplace no later than five calendar days after such conviction.

Yes No N/A

5. The Federal Aviation Administration (FAA) will be notified in writing within 10 calendar days after receiving notice under item 4b above from an employee or otherwise receiving actual notice of such conviction (2 CFR § 182.225). Employers of convicted employees must provide notice, including position title of the employee, to the FAA (2 CFR § 182.300).

Yes No N/A

6. One of the following actions (2 CFR § 182.225(b)) will be taken within 30 calendar days of receiving a notice under item 4b above with respect to any employee who is so convicted:

- a. Take appropriate personnel action against such an employee, up to and including termination, consistent with the requirements of the Rehabilitation Act of 1973, as amended; and
- b. Require such employee to participate satisfactorily in drug abuse assistance or rehabilitation programs approved for such purposes by a federal, state, or local health, law enforcement, or other appropriate agency.

Yes No N/A

7. A good faith effort will be made, on a continuous basis, to maintain a drug-free workplace through implementation of items 1 through 6 above (2 CFR § 182.200).

Yes No N/A

Site(s) of performance of work (2 CFR § 182.230):

Location 1

Name of Location:

Address:

WARREN COUNTY AIRPORT
2460 GREEN HILL RD
LEBANON OH 45036

Location 2 (if applicable)

Name of Location:

Address:

Location 3 (if applicable)

Name of Location:

Address:



U.S. Department
of Transportation

Federal Aviation
Administration

FAA Form 5100-135, Certification and Disclosure Regarding Potential Conflicts of Interest – Airport Improvement Program Sponsor Certification

Paperwork Reduction Act Burden Statement

A federal agency may not conduct or sponsor, and a person is not required to respond to, nor shall a person be subject to a penalty for failure to comply with a collection of information subject to the requirements of the Paperwork Reduction Act unless that collection of information displays a currently valid OMB Control Number. The OMB Control Number for this information collection is 2120-0569. Public reporting for this collection of information is estimated to be approximately 8 hours per response, including the time for reviewing instructions, searching existing data sources, gathering and maintaining the data needed, completing and reviewing the collection of information. All responses to this collection of information are required under 49 U.S.C. Section 47105 to retain a benefit and to meet the reporting requirements of 2 CFR 200. Send comments regarding this burden estimate or any other aspect of this collection of information, including suggestions for reducing this burden to the Federal Aviation Administration at: 800 Independence Ave. SW, Washington, DC 20591, Attn: Information Collection Clearance Officer, ASP-110.

3. The sponsor or sub-recipient certifies that is has disclosed and will disclose to the FAA any known potential conflict of interest (2 CFR § 1200.112).

Yes No

Attach documentation clarifying any above item marked with "no" response.

Sponsor's Certification

I certify, for the project identified herein, responses to the forgoing items are accurate as marked and additional documentation for any item marked "no" is correct and complete.

Executed on this 15 day of August, 2019.
(Day) (Month)

Name of Sponsor: Warren County Airport Authority, Ohio

Printed/Typed Name of Sponsor's Authorized Official: ALAN WOLFSON

Printed/Typed Title of Sponsor's Authorized Official: SECRETARY-TREASURER

Signature of Sponsor's Authorized Official: 

I declare under penalty of perjury that the foregoing is true and correct. I understand that knowingly and willfully providing false information to the federal government is a violation of 18 USC § 1001 (False Statements) and could subject me to fines, imprisonment, or both.

Sponsor's Certification

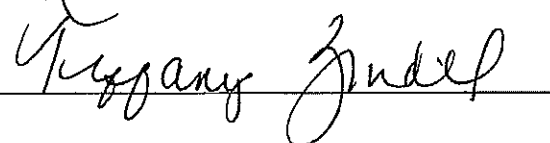
I certify, for the project identified herein, responses to the forgoing items are accurate as marked and additional documentation for any item marked "no" is correct and complete.

Executed on this 20th day of August, 2019.
(Day) (Month)

Name of Sponsor: Warren County Board of Commissioners, Ohio

Printed/Typed Name of Sponsor's Authorized Official: Tiffany M. Zindel
County Administrator

Printed/Typed Title of Sponsor's Authorized Official: County Administrator

Signature of Sponsor's Authorized Official: 

I declare under penalty of perjury that the foregoing is true and correct. I understand that knowingly and willfully providing false information to the federal government is a violation of 18 USC § 1001 (False Statements) and could subject me to fines, imprisonment, or both.



Construction Project Final Acceptance Airport Improvement Program Sponsor Certification

Sponsor: Warren County Airport Authority and Board of Commissioners, Ohio

Airport: Warren County/John Lane Field

Project Number: 3-39-0045-020-2019

Description of Work: Replace 4-box PAPI on Runway 1 and 19

Application

49 USC § 47105(d), authorizes the Secretary to require certification from the sponsor that it will comply with the statutory and administrative requirements in carrying out a project under the Airport Improvement Program. General standards for final acceptance and close out of federally funded construction projects are in 2 CFR § 200.343 – Closeout and supplemented by FAA Order 5100.38. The sponsor must determine that project costs are accurate and proper in accordance with specific requirements of the grant agreement and contract documents.

Certification Statements

Except for certification statements below marked not applicable (N/A), this list includes major requirements of the construction project. Selecting "yes" represents sponsor acknowledgement and confirmation of the certification statement. The term "will" means Sponsor action taken at appropriate time based on the certification statement focus area, but no later than the end of the project period of performance. This list is not comprehensive and does not relieve the sponsor from fully complying with all applicable statutory and administrative standards. The source of the requirement is referenced within parenthesis.

1. The personnel engaged in project administration, engineering supervision, project inspection and acceptance testing were or will be determined to be qualified and competent to perform the work (Grant Assurance).
 Yes No N/A

2. Construction records, including daily logs, were or will be kept by the resident engineer/construction inspector that fully document contractor's performance in complying with:
 - a. Technical standards (Advisory Circular (AC) 150/5370-12);
 - b. Contract requirements (2 CFR part 200 and FAA Order 5100.38); and
 - c. Construction safety and phasing plan measures (AC 150/5370-2). Yes No N/A

3. All acceptance tests specified in the project specifications were or will be performed and documented. (AC 150/5370-12).
 Yes No N/A

10. The project was or will be accomplished without material deviations, changes, or modifications from approved plans and specifications, except as approved by the FAA (Order 5100.38).

Yes No N/A

11. The construction of all buildings have complied or will comply with the seismic construction requirements of 49 CFR § 41.120.

Yes No N/A

12. For development projects, sponsor has taken or will take the following close-out actions:

- a) Submit to the FAA a final test and quality assurance report summarizing acceptance test results, as applicable (Grant Condition);
- b) Complete all environmental requirements as established within the project environmental determination (Order 5100.38); and
- c) Prepare and retain as-built plans (Order 5100.38).

Yes No N/A

13. Sponsor has revised or will revise their airport layout plan (ALP) that reflects improvements made and has submitted or will submit an updated ALP to the FAA no later than 90 days from the period of performance end date. (49 USC § 47107 and Order 5100.38).

Yes No N/A



U.S. Department of
Transportation

Federal Aviation
Administration

**FAA Form 5100-131, Equipment and Construction Contracts –
Airport Improvement Program Sponsor Certification**

Paperwork Reduction Act Burden Statement

A federal agency may not conduct or sponsor, and a person is not required to respond to, nor shall a person be subject to a penalty for failure to comply with a collection of information subject to the requirements of the Paperwork Reduction Act unless that collection of information displays a currently valid OMB Control Number. The OMB Control Number for this information collection is 2120-0569. Public reporting for this collection of information is estimated to be approximately 8 hours per response, including the time for reviewing instructions, searching existing data sources, gathering and maintaining the data needed, completing and reviewing the collection of information. All responses to this collection of information are required under 49 U.S.C. Section 47105 to retain a benefit and to meet the reporting requirements of 2 CFR 200. Send comments regarding this burden estimate or any other aspect of this collection of information, including suggestions for reducing this burden to: Information Collection Clearance Officer, Federal Aviation Administration, 10101 Hillwood Parkway, Fort Worth, TX 76177-1524.

3. Sponsors that are required to have a Disadvantage Business Enterprise (DBE) program on file with the FAA have included or will include clauses required by Title VI of the Civil Rights Act and 49 CFR part 26 for Disadvantaged Business Enterprises in all contracts and subcontracts.

Yes No N/A

4. Sponsors required to have a DBE program on file with the FAA have implemented or will implement monitoring and enforcement measures that:

- a. Ensure work committed to Disadvantaged Business Enterprises at contract award is actually performed by the named DBEs (49 CFR § 26.37(b));
- b. Include written certification that the sponsor has reviewed contract records and has monitored work sites for performance by DBE firms (49 CFR § 26.37(b)); and
- c. Provides for a running tally of payments made to DBE firms and a means for comparing actual attainments (i.e. payments) to original commitments (49 CFR § 26.37(c)).

Yes No N/A

5. Sponsor procurement actions using the competitive sealed bid method (2 CFR § 200.320(c)) was or will be:

- a. Publicly advertised, allowing a sufficient response time to solicit an adequate number of interested contractors or vendors;
- b. Prepared to include a complete, adequate and realistic specification that defines the items or services in sufficient detail to allow prospective bidders to respond;
- c. Publicly opened at a time and place prescribed in the invitation for bids; and
- d. Prepared in a manner that result in a firm fixed price contract award to the lowest responsive and responsible bidder.

Yes No N/A

6. For projects the Sponsor proposes to use the competitive proposal procurement method (2 CFR § 200.320(d)), Sponsor has requested or will request FAA approval prior to proceeding with a competitive proposal procurement by submitting to the FAA the following:

- a. Written justification that supports use of competitive proposal method in lieu of the preferred sealed bid procurement method;
- b. Plan for publicizing and soliciting an adequate number of qualified sources; and
- c. Listing of evaluation factors along with relative importance of the factors.

Yes No N/A

7. For construction and equipment installation projects, the bid solicitation includes or will include the current federal wage rate schedule(s) for the appropriate type of work classifications (2 CFR Part 200, Appendix II).

Yes No N/A

13. All contracts and subcontracts exceeding \$25,000: Measures are in place or will be in place (e.g. checking the System for Award Management) that ensure contracts and subcontracts are not awarded to individuals or firms suspended, debarred, or excluded from participating in federally assisted projects (2 CFR parts 180 and 1200).

Yes No N/A

14. Contracts exceeding the simplified acquisition threshold (currently \$250,000) include or will include provisions, as applicable, that address the following:

- a. Construction and equipment installation contracts - a bid guarantee of 5%, a performance bond of 100%, and a payment bond of 100% (2 CFR § 200.325);
- b. Construction and equipment installation contracts - requirements of the Contract Work Hours and Safety Standards Act (40 USC 3701-3708, Sections 103 and 107);
- c. Restrictions on Lobbying and Influencing (2 CFR part 200, Appendix II);
- d. Conditions specifying administrative, contractual and legal remedies for instances where contractor or vendor violate or breach the terms and conditions of the contract (2 CFR §200, Appendix II); and
- e. All Contracts - Applicable standards and requirements issued under Section 306 of the Clean Air Act (42 USC 7401-7671q), Section 508 of the Clean Water Act (33 USC 1251-1387, and Executive Order 11738.

Yes No N/A

[Faint, illegible text, possibly a stamp or signature]



U.S. Department of
Transportation

Federal Aviation
Administration

FAA Form 5100-132, Project Plans and Specifications – Airport Improvement Program Sponsor Certification

Paperwork Reduction Act Burden Statement

A federal agency may not conduct or sponsor, and a person is not required to respond to, nor shall a person be subject to a penalty for failure to comply with a collection of information subject to the requirements of the Paperwork Reduction Act unless that collection of information displays a currently valid OMB Control Number. The OMB Control Number for this information collection is 2120-0569. Public reporting for this collection of information is estimated to be approximately 8 hours per response, including the time for reviewing instructions, searching existing data sources, gathering and maintaining the data needed, completing and reviewing the collection of information. All responses to this collection of information are required under 49 U.S.C. Section 47105 to retain a benefit and to meet the reporting requirements of 2 CFR 200. Send comments regarding this burden estimate or any other aspect of this collection of information, including suggestions for reducing this burden to the Federal Aviation Administration at: 800 Independence Ave. SW, Washington, DC 20591, Attn: Information Collection Clearance Officer, ASP-110.

4. Development and features that are ineligible or unallowable for AIP funding have been or will be omitted from the plans and specifications (FAA Order 5100.38, par. 3-43).
- Yes No N/A
5. The specification does not use or will not use "brand name" or equal to convey requirements unless sponsor requests and receives approval from the FAA to use brand name (FAA Order 5100.38, Table U-5).
- Yes No N/A
6. The specification does not impose or will not impose geographical preference in their procurement requirements (2 CFR §200.319(b) and FAA Order 5100.38, Table U-5).
- Yes No N/A
7. The use of prequalified lists of individuals, firms or products include or will include sufficient qualified sources that ensure open and free competition and that does not preclude potential entities from qualifying during the solicitation period (2 CFR §319(d)).
- Yes No N/A
8. Solicitations with bid alternates include or will include explicit information that establish a basis for award of contract that is free of arbitrary decisions by the sponsor (2 CFR § 200.319(a)(7)).
- Yes No N/A
9. Concurrence was or will be obtained from the FAA if Sponsor incorporates a value engineering clause into the contract (FAA Order 5100.38, par. 3-57).
- Yes No N/A
10. The plans and specifications incorporate or will incorporate applicable requirements and recommendations set forth in the federally approved environmental finding (49 USC §47106(c)).
- Yes No N/A
11. The design of all buildings comply or will comply with the seismic design requirements of 49 CFR § 41.120. (FAA Order 5100.38d, par. 3-92)
- Yes No N/A
12. The project specification include or will include process control and acceptance tests required for the project by as per the applicable standard:
- Construction and installation as contained in Advisory Circular (AC) 150/5370-10.
 Yes No N/A
 - Snow Removal Equipment as contained in AC 150/5220-20.
 Yes No N/A
 - Aircraft Rescue and Fire Fighting (ARFF) vehicles as contained in AC 150/5220-10.

Attach documentation clarifying any above item marked with "no" response.

Sponsor's Certification

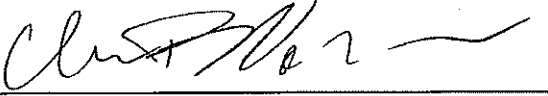
I certify, for the project identified herein, responses to the forgoing items are accurate as marked and additional documentation for any item marked "no" is correct and complete.

Executed on this 15 day of August, 2019.
(Day) (Month)

Name of Sponsor: Warren County Airport Authority, Ohio

Printed/Typed Name of Sponsor's Authorized Official: ALAN WOLFSON

Printed/Typed Title of Sponsor's Authorized Official: SECRETARY-TREASURER

Signature of Sponsor's Authorized Official: 

I declare under penalty of perjury that the foregoing is true and correct. I understand that knowingly and willfully providing false information to the federal government is a violation of 18 USC § 1001 (False Statements) and could subject me to fines, imprisonment, or both.

Sponsor's Certification

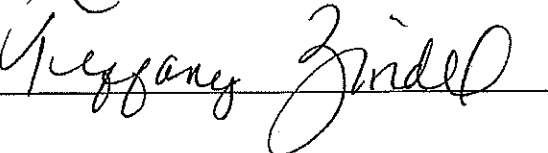
I certify, for the project identified herein, responses to the forgoing items are accurate as marked and additional documentation for any item marked "no" is correct and complete.

Executed on this 20th day of August, 2019.
(Day) (Month)

Name of Sponsor: Warren County Board of Commissioners, Ohio

Printed/Typed Name of Sponsor's Authorized Official: Tiffany M. Zindel

Printed/Typed Title of Sponsor's Authorized Official: County Administrator

Signature of Sponsor's Authorized Official: 

I declare under penalty of perjury that the foregoing is true and correct. I understand that knowingly and willfully providing false information to the federal government is a violation of 18 USC § 1001 (False Statements) and could subject me to fines, imprisonment, or both.



Selection of Consultants

Airport Improvement Program Sponsor Certification

Sponsor: Warren County Airport Authority and Board of Commissioners, Ohio

Airport: Warren County/John Lane Field

Project Number: 3-39-0045-020-2019

Description of Work: Replace 4-box PAPI on Runway 1 and 19

Application

49 USC § 47105(d) authorizes the Secretary to require certification from the sponsor that it will comply with the statutory and administrative requirements in carrying out a project under the Airport Improvement Program (AIP). General requirements for selection of consultant services within federal grant programs are described in 2 CFR §§ 200.317-200.326. Sponsors may use other qualifications-based procedures provided they are equivalent to standards of Title 40 chapter 11 and FAA Advisory Circular 150/5100-14, Architectural, Engineering, and Planning Consultant Services for Airport Grant Projects.

Certification Statements

Except for certification statements below marked as not applicable (N/A), this list includes major requirements of the construction project. Selecting "yes" represents sponsor acknowledgement and confirmation of the certification statement. The term "will" means Sponsor action taken at appropriate time based on the certification statement focus area, but no later than the end of the project period of performance. This list is not comprehensive and does not relieve the sponsor from fully complying with all applicable statutory and administrative standards. The source of the requirement is referenced within parenthesis.

1. Sponsor acknowledges their responsibility for the settlement of all contractual and administrative issues arising out of their procurement actions (2 CFR § 200.318(k)).
 Yes No N/A
2. Sponsor procurement actions ensure or will ensure full and open competition that does not unduly limit competition (2 CFR § 200.319).
 Yes No N/A
3. Sponsor has excluded or will exclude any entity that develops or drafts specifications, requirements, or statements of work associated with the development of a request-for-qualifications (RFQ) from competing for the advertised services (2 CFR § 200.319).
 Yes No N/A
4. The advertisement describes or will describe specific project statements-of-work that provide clear detail of required services without unduly restricting competition (2 CFR § 200.319).
 Yes No N/A

14. Sponsor is not using or will not use the prohibited cost-plus-percentage-of-cost (CPPC) contract method. (2 CFR § 200.323(d)).

Yes No N/A

Sponsor's Certification

I certify, for the project identified herein, responses to the forgoing items are accurate as marked and additional documentation for any item marked "no" is correct and complete.

Executed on this 15 day of AUGUST, 2019.
(Day) (Month)

Name of Sponsor: Warren County Airport Authority, Ohio

Printed/Typed Name of Sponsor's Authorized Official: Alex Wolfford

Printed/Typed Title of Sponsor's Authorized Official: SECRETARY-TREASURER

Signature of Sponsor's Authorized Official: 

I declare under penalty of perjury that the foregoing is true and correct. I understand that knowingly and willfully providing false information to the federal government is a violation of 18 USC § 1001 (False Statements) and could subject me to fines, imprisonment, or both.

Sponsor's Certification

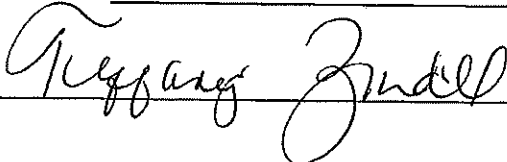
I certify, for the project identified herein, responses to the forgoing items are accurate as marked and additional documentation for any item marked "no" is correct and complete.

Executed on this 20th day of August, 2019.
(Day) (Month)

Name of Sponsor: Warren County Board of Commissioners, Ohio

Printed/Typed Name of Sponsor's Authorized Official: **Tiffany M. Zindel**

Printed/Typed Title of Sponsor's Authorized Official: **County Administrator**

Signature of Sponsor's Authorized Official: 

I declare under penalty of perjury that the foregoing is true and correct. I understand that knowingly and willfully providing false information to the federal government is a violation of 18 USC § 1001 (False Statements) and could subject me to fines, imprisonment, or both.

Resolution

Number 19-1076

Adopted Date August 20, 2019

REAFFIRM DOG REGISTRATION FEES FOR 2020

BE IT RESOLVED, to reaffirm the following for dog registration and kennel fees for 2020:

One (1) Year Dog License Registration	\$ 15.00
Three (3) Year Dog License Registration	\$ 45.00
Permanent Dog License Registration	\$150.00
Kennel License Registration	\$ 75.00
Three (3) Year Delinquent Dog Registration w/ Penalty (February 1-November 30)	\$ 60.00
Three (3) Year New Dog Registration Fee (July 1 – November 30)	\$ 37.35 (83% of fee)
Permanent Delinquent Dog Registration w/ Penalty (February 1-November 30)	\$ 165.00
Permanent New Dog Registration Fee (July 1 – November 30)	\$ 150.00
Dog Pick-up	\$ 20.00
Posting Notice	\$ 5.00
Board-per-day	\$ 5.00
Euthanasia	\$ 30.00
Disposal	\$ 10.00

BE IT FURTHER RESOLVED that said fee schedule shall remain in effect until such time as a resolution is adopted by this Board of County Commissioners to modify said fee schedule.

Mr. Young moved for adoption of the foregoing resolution being seconded by Mr. Grossmann. Upon call of the roll, the following vote resulted:

Mrs. Jones – yea
Mr. Grossmann – yea
Mr. Young – yea

Resolution adopted this 20th day of August 2019.

BOARD OF COUNTY COMMISSIONERS



Tina Osborne, Clerk

/tao

cc: Auditor _____
Dog & Kennel (file)
Humane Association

Resolution

Number 19-1077

Adopted Date August 20, 2019

ISSUE REQUEST FOR ENGINEERING QUALIFICATIONS FOR THE PROCUREMENT OF PROFESSIONAL ENGINEERING SERVICES RELATED TO THE FY2019 MORROW GIS COMMUNITY DEVELOPMENT BLOCK GRANT PROJECT.

WHEREAS, Section 153.67 of the Ohio Revised Code identifies that all public authorities planning to contract for professional design service shall publicly announce all contracts available from it for such services and specifies the contents of the announcements; and

WHEREAS, the Warren County Board of County Commissioners has awarded the Village of Morrow funding for their GIS project with CDBG funds; and

WHEREAS, the Warren County Board of County Commissioners wish to procure the services of professional engineering firms to begin the aforementioned project; and

WHEREAS, Section 153.65-71 of the Ohio Revised Code further identifies the requirements and procedures for procuring the services of a consulting engineering firm for the development of studies, plans, specifications, and bid documents; and

NOW THEREFORE BE IT RESOLVED, that the Office of Grants Administration is hereby authorized and directed to issue the enclosed public notice, for the procurement of engineering services for the aforesated project in accordance with applicable sections of the Ohio Revised Code.

Mr. Young moved for adoption of the foregoing resolution being seconded by Mr. Grossmann. Upon call of the roll, the following vote resulted:

Mrs. Jones – yea
Mr. Grossmann – yea
Mr. Young – yea

Resolution adopted this 20th day of August 2019.

BOARD OF COUNTY COMMISSIONERS



Tina Osborne, Clerk

/sm

cc: OGA (file)
Project File
Bid File
K. Hawk

Resolution

Number 19-1078

Adopted Date August 20, 2019

WAIVE SEWER CONNECTION FEES FOR THE WAYNE LOCAL SCHOOL DISTRICT NEW ELEMENTARY BUILDING

WHEREAS, Wayne Local School District is constructing a new elementary school at 659 Dayton Road, Waynesville, OH 45068; and

WHEREAS, the aforementioned facility will receive sewer service from the Warren County Sewer Department through the installation of a sanitary sewer lateral by a private contractor; and

WHEREAS, the Wayne Local School District have requested the waiver of sewer connection fees; and

WHEREAS, it is the desire of this Board to waive the aforementioned fees for the planned improvements; and

NOW THEREFORE BE IT RESOLVED:

1. That the sewer connection charges at the Wayne Local School District New Elementary Building are hereby waived:
2. That the following fees shall be applicable to Wayne Local School District:

Sewer Inspection Fee	\$80
----------------------	------
3. That the Wayne Local School District shall be responsible for all costs associated with the construction of sewer service from the County's existing sewer main to the proposed facilities.
4. That all work must be inspected by a representative of the Warren County Water and Sewer Department.

Mr. Young moved for adoption of the foregoing resolution being seconded by Mr. Grossmann. Upon call of the roll, the following vote resulted:

Mrs. Jones – yea
Mr. Grossmann – yea
Mr. Young – yea

Resolution adopted this 20th day of August 2019.

BOARD OF COUNTY COMMISSIONERS


Tina Osborne, Clerk

cc: Water/Sewer (file)
Wayne Local Schools (file)

Resolution

Number 19-1079

Adopted Date August 20, 2019

APPROVE BOND RELEASE FOR OTTERBEIN LEBANON, LLC FOR COMPLETION OF IMPROVEMENTS IN OTTERBEIN MAINTENANCE FACILITIES SITUATED IN TURTLECREEK TOWNSHIP

BE IT RESOLVED to approve the following bond release upon recommendation of the Warren County Soil and Water Conservation District:

EROSION CONTROL PERFORMANCE BOND RELEASE

Bond Number	:	N/A
Development	:	Otterbein Maintenance Facilities
Developer	:	Otterbein Lebanon, LLC
Township	:	Turtlecreek
Amount	:	\$8,802.30
Surety Company	:	Hartford Fire Insurance Company (33BSBHU0114)

Mr. Young moved for adoption of the foregoing resolution being seconded by Mr. Grossmann. Upon call of the roll, the following vote resulted:

Mrs. Jones – yea
Mr. Grossmann – yea
Mr. Young – yea

Resolution adopted this 20th day of August 2019.

BOARD OF COUNTY COMMISSIONERS


Tina Osborne, Clerk

cc: Developer
Surety Co.
Soil & Water (file)
Bond Agreement file

Resolution

Number 19-1080

Adopted Date August 20, 2019

APPROVE A SUBDIVISION PUBLIC IMPROVEMENT PERFORMANCE AND MAINTENANCE SECURITY RELEASE WITH STONERIDGE DEVELOPMENT, LTD. FOR COUNTRY BROOK NORTH, SECTION NINE SITUATED IN CLEARCREEK TOWNSHIP

BE IT RESOLVED, upon recommendation of the Warren County Sanitary Engineer, to release the following security agreement:

RELEASE

Bond Number	:	14-009 (W/S)
Development	:	Country Brook North, Section Nine
Developer	:	Stoneridge Development, Ltd.
Township	:	Clearcreek
Amount	:	\$16,579.07
Surety Company	:	Cashier's Check – The Citizens National Bank #024368

Mr. Young moved for adoption of the foregoing resolution being seconded by Mr. Grossmann. Upon call of the roll, the following vote resulted:

Mrs. Jones – yea
Mr. Grossmann – yea
Mr. Young – yea

Resolution adopted this 20th day of August 2019.

BOARD OF COUNTY COMMISSIONERS



Tina Osborne, Clerk

cgb

cc: Stoneridge Development, Ltd., Bob Abernathy, Agent, PO Box 757, Springboro OH 45066
OMB – S. Spencer
Water/Sewer (file)
Bond Agreement file

Resolution

Number 19-1081

Adopted Date August 20, 2019

APPROVE A STREET AND APPURTENANCES (INCLUDING SIDEWALKS) BOND REDUCTION FOR PENDRAGON DEVELOPMENT COMPANY, LLC, FOR COMPLETION OF PERFORMANCE OF CONSTRUCTION OF IMPROVEMENTS AND ENTER INTO THE MAINTENANCE SECURITY FOR ABERLIN SPRINGS, PHASE ONE, SITUATED IN UNION TOWNSHIP

WHEREAS, the Developer has completed the performance of the construction of improvements subject of the Bond referenced below, and upon recommendation of the County Engineer the bond amount for performance may be reduced to zero, but the bond shall remain in effect for maintenance security to secure the performance of all maintenance upon the completed improvements; and

NOW THEREFORE BE IT RESOLVED, upon recommendation of the Warren County Engineer, to approve the following street and appurtenances performance bond reduction and the two year maintenance period:

BOND REDUCTION

Bond Number	:	17-008 (P/S-M)
Development	:	Aberlin Springs, Phase One
Developer	:	Pendragon Development Company, LLC
Township	:	Union
Reduction Amount	:	\$89,152.39
Surety Company	:	Ironshore Indemnity Inc. (SUR21100060)


BE IT FURTHER RESOLVED: the original amount of bond was \$202,751.06 and after the above reduction, the remaining bond amount is \$113,598.67.

Mr. Young moved for adoption of the foregoing resolution being seconded by Mr. Grossmann. Upon call of the roll, the following vote resulted:

Mrs. Jones – yea
Mr. Grossmann – yea
Mr. Young – yea

Resolution adopted this 20th day of August 2019.

BOARD OF COUNTY COMMISSIONERS



Tina Osborne, Clerk

cc: Pendragon Dev. Co., LLC, 3470 Snook Road, Morrow, Oh 45152
Ironshore Indemnity, Inc., One State Street Plaza, 7th Floor, New York, NY 10004
Engineer (file)
Bond Agreement file

Resolution

Number 19-1082

Adopted Date August 20, 2019

APPROVE RECORD PLATS

BE IT RESOLVED, upon recommendation of the Warren County Regional Planning Commission, to approve the following plats:

- Saddlebrooke Farm Replat 5 – Clearcreek Twp.

Mr. Young moved for adoption of the foregoing resolution being seconded by Mr. Grossmann. Upon call of the roll, the following vote resulted:

Mrs. Jones – yea
Mr. Grossmann – yea
Mr. Young – yea

Resolution adopted this 20th day of August 2019.

BOARD OF COUNTY COMMISSIONERS



Tina Osborne, Clerk

cc: Plat File
RPC

*BOARD OF COUNTY COMMISSIONERS
WARREN COUNTY, OHIO*

Resolution

Number 19-1083

Adopted Date August 20, 2019

APPROVE A SUPPLEMENTAL APPROPRIATION INTO COUNTY COMMISSIONERS'
GRANT FUND #11011111

BE IT RESOLVED, to approve the following supplemental appropriation:

\$1,617.00 into #11011111-5797 (OKI Share)

\$2,332.50 into #11011111-5722 (Agricultural Society)

Mr. Young moved for adoption of the foregoing resolution being seconded by Mr. Grossmann.
Upon call of the roll, the following vote resulted:

Mrs. Jones – yea
Mr. Grossmann – yea
Mr. Young – yea

Resolution adopted this 20th day of August 2019.

BOARD OF COUNTY COMMISSIONERS



Tina Osborne, Clerk

cc: Auditor _____
Supplemental App. file
Commissioners' file
OMB

**BOARD OF COUNTY COMMISSIONERS
WARREN COUNTY, OHIO**

Resolution

Number 19-1084

Adopted Date August 20, 2019

APPROVE SUPPLEMENTAL APPROPRIATION ADJUSTMENTS WITHIN SHERIFF'S OFFICE FUND #2286 & 2295

BE IT RESOLVED, to approve the following supplemental appropriation adjustments within Warren County Sheriff's Office Fund #2286 & 2295:

\$2,000.00	22862200 5400	Purchased Services
\$2,000.00	22952200 5317	Non Capital Purchase

Mr. Young moved for adoption of the foregoing resolution being seconded by Mr. Grossmann. Upon call of the roll, the following vote resulted:

Mrs. Jones – yea
Mr. Grossmann – yea
Mr. Young – yea

Resolution adopted this 20th day of August 2019.

BOARD OF COUNTY COMMISSIONERS



Tina Osborne, Clerk

cc: Auditor _____
Supplemental App. file
Sheriff (file)
OMB

*BOARD OF COUNTY COMMISSIONERS
WARREN COUNTY, OHIO*

Resolution

Number 19-1085

Adopted Date August 20, 2019

APPROVE APPROPRIATION ADJUSTMENT WITHIN THE CLERK OF COURT'S
GENERAL FUND #11011260

BE IT RESOLVED, to approve the following appropriation adjustment:


\$ 2,200.00 from #11011260 5830 (Workers Compensation)
into #11011260 5910 (Other Expenses)

Mr. Young moved for adoption of the foregoing resolution being seconded by Mr. Grossmann.
Upon call of the roll, the following vote resulted:

Mrs. Jones – yea
Mr. Grossmann – yea
Mr. Young – yea

Resolution adopted this 20th day of August 2019.

BOARD OF COUNTY COMMISSIONERS


Tina Osborne, Clerk

cc: Auditor _____
Appropriation Adj. file
Clerk of Courts (file)

**BOARD OF COUNTY COMMISSIONERS
WARREN COUNTY, OHIO**

Resolution

Number 19-1086

Adopted Date August 20, 2019

APPROVE APPROPRIATION ADJUSTMENTS WITHIN THE AUDITOR'S OFFICE
FUNDS 2237 AND 11011120

NOW THEREFORE BE IT RESOLVED, to approve the following budget transfers:

\$19,771.63	From	# 22371120-5400 (Purchased Services)
\$14,782.87	Into	# 22371120-5881 (Sick Leave Payout)
\$4,988.76	Into	# 22371120-5882 (Vacation Leave Payout)
\$2,500.00	From	# 11011120-5400 (Purchased Services)
\$2,500.00	Into	# 11011120-5210 (Material and Supplies)

Mr. Young moved for adoption of the foregoing resolution being seconded by Mr. Grossmann.
Upon call of the roll, the following vote resulted:

Mrs. Jones – yea
Mr. Grossmann – yea
Mr. Young – yea

Resolution adopted this 20th day of August 2019.

BOARD OF COUNTY COMMISSIONERS


Tina Osborne, Clerk

cc: Auditor (file)
Appropriation adjustment (file)

*BOARD OF COUNTY COMMISSIONERS
WARREN COUNTY, OHIO*

Resolution

Number 19-1087

Adopted Date Aug 13, 2019

APPROVE APPROPRIATION ADJUSTMENT WITHIN ENGINEER'S OFFICE FUND #5590

BE IT RESOLVED, to approve the following appropriation adjustment:

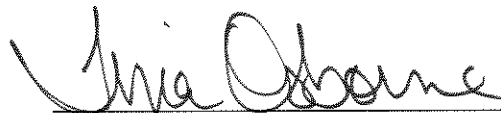
\$40,000 from #55903090-5102 (Salaries)
 into #55903090-5400 (Purchased Svc)

Mr. Young moved for adoption of the foregoing resolution being seconded by Mr. Grossmann.
Upon call of the roll, the following vote resulted:

Mrs. Jones – yea
Mr. Grossmann – yea
Mr. Young – yea

Resolution adopted this 20th day of August 2019.

BOARD OF COUNTY COMMISSIONERS



Tina Osborne, Clerk

cc: Auditor _____
Appropriation Adj. file
Engineer (file)
OMB

**BOARD OF COUNTY COMMISSIONERS
WARREN COUNTY, OHIO**

Resolution

Number 19-1088

Adopted Date August 20, 2019

APPROVE APPROPRIATION ADJUSTMENT WITHIN WCSO FUNDS #6630

BE IT RESOLVED, to approve the following appropriation adjustment within Warren County Sheriff's Office Fund #6630:

\$8,810.74	from 66302251 5830	Worker's Comp
	into 66302251 5881	Sick Leave Payout
\$10,480.79	from 66302251 5830	Worker's Comp
	into 66302251 5882	Vacation Leave Payout

Mr. Young moved for adoption of the foregoing resolution being seconded by Mr. Grossmann. Upon call of the roll, the following vote resulted:

Mrs. Jones – yea
Mr. Grossmann – yea
Mr. Young – yea

Resolution adopted this 20th day of August 2019.

BOARD OF COUNTY COMMISSIONERS



Tina Osborne, Clerk

cc: Auditor _____
Appropriation Adjustment file
Sheriff's Office (file)
OMB

*BOARD OF COUNTY COMMISSIONERS
WARREN COUNTY, OHIO*

Resolution

Number 19-1089

Adopted Date August 20, 2019

ACKNOWLEDGE PAYMENT OF BILLS

BE IT RESOLVED, to acknowledge payment of bills from 8/14/19 and 8/19/19 as attached hereto and made a part hereof.

Mr. Young moved for adoption of the foregoing resolution being seconded by Mr. Grossmann. Upon call of the roll, the following vote resulted:

Mrs. Jones – yea
Mr. Grossmann – yea
Mr. Young – yea

Resolution adopted this 20th day of August 2019.

BOARD OF COUNTY COMMISSIONERS



Tina Osborne, Clerk

/tao

cc: Auditor ____

Resolution

Number 19-1090

Adopted Date August 20, 2019

RESOLUTION AUTHORIZING THE ISSUANCE OF NOT TO EXCEED \$630,000 OF SPECIAL ASSESSMENT BONDS (ESTATES OF KEEVER CREEK TURN LANE)

WHEREAS, the County Auditor of the County of Warren, Ohio, has heretofore certified that the estimated life of the construction of a turn lane off of State Route 741 into the development known as The Estates of Keever Creek (the "Project") is at least five (5) years, and has certified that the maximum maturity of the bonds issued therefor, in accordance with the special assessment proceedings, is twenty (20) years;

NOW, THEREFORE, BE IT RESOLVED by the Board of County Commissioners of the County of Warren (herein the "County"), Ohio:

SECTION 1. That it is necessary to issue and sell bonds of the County of Warren, Ohio, in the principal sum not to exceed \$630,000 in anticipation of the levy and collection of special assessments, for the purpose of (1) financing the costs of the Project and (2) paying certain costs related to the issuance of bonds, together with other permissible costs under the Uniform Public Securities Law. Said Bonds shall be issued and sold pursuant to Section 133 of the Ohio Revised Code and this resolution. The bond issue shall be designated "Special Assessment Bonds (Estates of Keever Creek Turn Lane)" (the "Bonds"). The proceeds from the sale of the Bonds shall be apportioned, deposited and credited in accordance with Section 133.32 of the Revised Code to the purpose set forth in the preambles hereto.

SECTION 2. That bonds of the County of Warren, Ohio shall be issued in said principal sum not to exceed \$630,000 for the purpose aforesaid under authority of the general laws of the State of Ohio, particularly the Uniform Public Securities Law of the Revised Code. Said Bonds shall be dated their date of issuance, shall be sold to the County Treasurer in accordance with its offer, and shall be issued as fully registered bonds in the denominations as requested by the County Treasurer. The Bonds may be issued in certificate form registered in the name of the purchaser thereof or in book-entry only form registered in the name or street name of the depository. The Bonds shall bear interest at the rate of two and one-quarter percent (2.25%), payable semiannually on each June 1 and December 1, commencing June 1, 2020, until maturity, shall mature December 1, 2039 and shall be subject to mandatory sinking fund redemption on the 1st day of December of the years 2020 through 2038 as set forth in the certificate of award (the "Certificate of Award") of the County Auditor. Interest shall be calculated on a 30-day month, 360 day year basis. The County Auditor shall be the paying agent, registrar and transfer agent (the "Paying Agent and Registrar") for the Bonds.

The Bonds are subject to redemption prior to maturity at the option of the County.

If fewer than all of the outstanding Bonds of a single maturity are called for redemption, the selection of Bonds to be redeemed, or portion thereof, shall be made by lot by the Paying Agent and Registrar in any manner which the Paying Agent and Registrar may determine.

At least thirty (30) days before the redemption date of any Bonds, the Paying Agent and Registrar shall cause a notice of such redemption either in whole or in part, signed by the Paying Agent and Registrar, to be mailed, postage prepaid, to all registered owners of bonds to be redeemed in whole or in part at their addresses as they appear on the registration books kept by the Paying Agent and Registrar, but failure so to file or mail any such notice shall not affect the validity of the proceedings for such redemption. Each such notice shall set forth the date fixed for redemption, the redemption price to be paid and, if less than all of the Bonds being payable by their terms on a single date then outstanding shall be called for redemption, the distinctive numbers or letters, if any, of such Bonds to be redeemed. So long as the County Treasurer is the owner of one hundred percent of the outstanding Bonds, the foregoing notice provisions shall not apply.

On the date so designated for redemption, notice having been published in the manner and under the conditions hereinabove provided and moneys for payment of the redemption price being held in separate accounts by the Paying Agent and Registrar for the holders of the Bonds to be redeemed, the Bonds so called for redemption shall become and be due and payable at the redemption price provided for redemption of such Bonds on such date, interest on the Bonds so called for redemption shall cease to accrue, and the registered owners of such Bonds shall have no rights in respect thereof except to receive payment of the redemption price thereof.

SECTION 3. The Bonds shall express upon their faces the purpose for which they are issued and that they are issued in pursuance of this resolution. The Bonds shall be in fully registered form. The Bonds shall bear the signatures of the members of this Board of County Commissioners and of the County Auditor, which may be facsimile signatures, and may, but shall not be required to, have the County Auditor's seal or facsimile thereof affixed, provided that the Bonds shall bear the manual authenticating signature of an authorized representative of the Paying Agent and Registrar for the Bonds. The principal amount of each Bond shall be payable at the principal office of the Paying Agent and Registrar and interest thereon shall be payable on each interest payment date to the person whose name appears on the record date (May 15 and November 15 for each June 1 and December 1 interest payment date, respectively) on the bond registration records as the registered owner thereof, by check or draft mailed to such registered owner's address as it appears on such registration records.

The Bonds shall be transferable by the registered holder thereof in person or by his attorney duly authorized in writing at the principal office of the Paying Agent and Registrar upon presentation and surrender thereof to the Paying Agent and Registrar. The County and the Paying Agent and Registrar shall not be required to transfer any Bond during the 15-day period preceding any interest payment date, and no such transfer shall be effective until entered upon the registration records maintained by the Paying Agent and Registrar. Upon such transfer, a new Bond or Bonds of authorized denominations of the same maturity and for the same aggregate principal amount will be issued to the transferee in exchange therefor.

The County and the Paying Agent and Registrar may deem and treat the registered owner of the Bonds as the absolute owner thereof for all purposes, and neither the County nor the Paying Agent and Registrar shall be affected by any notice to the contrary.

Notwithstanding any other provision of this resolution to the contrary, with the approval of the County, the Paying Agent and Registrar may enter into an agreement with the registered owner of a Bond providing for making all payments to that registered owner of principal of and interest on, and any premium on that Bond or any portion thereof (other than any payment of the entire unpaid principal amount thereof) at a place and in a manner (including wire transfer of federal funds) other than as provided above in this resolution, without prior presentation or surrender of such Bond, upon any conditions which shall be satisfactory to the Paying Agent and Registrar and the County. That payment in any event shall be made to the person who is the registered owner of such Bond on the date that principal and premium is due, or with respect to the payment of interest, as of the applicable record date or other date agreed upon, as the case may be. The Paying Agent and Registrar will furnish a copy of each of these agreements, certified to be correct by an officer of the Paying Agent and Registrar, to any other paying agents for the Bonds and to the County. Any payment of principal, premium or interest pursuant to such an agreement shall constitute payment thereof pursuant to, and for all purposes of, this resolution.

Pursuant to the preceding paragraph, bond service charges on the Bonds shall be payable in the next day or federal funds delivered or transmitted (i) in the case of interest, on each interest payment date, and (ii) in all other cases, upon presentation and surrender of Bonds as provided in this resolution.

SECTION 4. That for the payment of said Bonds and the interest thereon, the full faith, credit and revenues of the County are hereby irrevocably pledged and for the purpose of providing the necessary funds to pay the interest on the foregoing issue of Bonds promptly when and as the same falls due, and also to provide a fund sufficient to discharge the Bonds at maturity, there shall be and is hereby levied on all the taxable property in said County, in addition to all other taxes, a direct tax annually during the period said Bonds are to run, inside of the limitations of Section 2 of Article XII of the Constitution of Ohio, which tax shall be sufficient in amount to provide for the payment of the interest upon said Bonds when and as the same falls due and to provide for the retirement and discharge of the principal of said Bonds at maturity.

Said tax shall be and is hereby ordered computed, certified, levied and extended upon the tax duplicate and collected by the same officers, in the same manner and at the same time that taxes for general purposes for each of said years are certified, extended and collected. Said tax shall be placed before and in preference to all other items and for the full amount thereof. The funds derived from said tax levies hereby required shall be placed in a separate and distinct fund, which, together with all interest collected on the same, shall be irrevocably pledged for the payment of the interest and the principal of said Bonds when and as the same fall due; provided,

however, to the extent that in each year other available funds are appropriated and applied to the payment of the principal and interest of said Bonds, including special assessment payments, the amount of such tax shall be reduced by the amount of said funds so appropriated and applied to such payment.

SECTION 5. The County Auditor is hereby authorized to execute and deliver to the County Treasurer and Dinsmore & Shohl LLP, bond counsel, the Certificate of Award which contains the mandatory sinking fund redemption provisions and other provisions with respect to the Bonds.

SECTION 6. That said Bonds shall be sold to the County Treasurer at the price of par, plus accrued interest. The proceeds from the sale of said Bonds, except any accrued interest thereon, shall be used for the purpose aforesaid and for no other purpose and the accrued interest received from such sale shall be transferred to the bond retirement fund to be applied to the payment of the principal and interest of said Bonds in the manner provided by law and the premium shall be used to pay costs of issuance of the Bonds.

SECTION 7. That it is found and determined that all formal actions of this Board of County Commissioners concerning and relating to the adoption of this resolution were adopted in an open meeting of this Board; and that all deliberations of this Board of County Commissioners and of any of its committees that resulted in such formal action, were in meetings open to the public, in compliance with the law.

SECTION 8. The Clerk of this Board is hereby directed to forward a copy of this resolution to the County Auditor.

Mr. Young moved for adoption of the foregoing resolution being seconded by Mr. Grossmann. Upon call of the roll, the following vote resulted:

Mrs. Jones – yea
Mr. Grossmann – yea
Mr. Young – yea

Resolution adopted this 20th day of August 2019.


BOARD OF COUNTY COMMISSIONERS


Tina Osborne, Clerk

RESOLUTION #19-1090
AUGUST 20, 2019
PAGE 5

CERTIFICATE


I hereby certify that the foregoing is a true and correct copy of a resolution adopted by the Board of County Commissioners of the County of Warren, Ohio, on the 20th day of August, 2019.



Clerk of said Board

CERTIFICATE AND RECEIPT

The undersigned hereby acknowledges certification by the receipt of a certified copy of a resolution adopted on the 20th day of August, 2019.




County Auditor

#15301943v1

CERTIFICATE AS TO MAXIMUM MATURITY OF BONDS

The undersigned County Auditor of Warren County, Ohio, being the fiscal officer thereof within the meaning of Section 133.01 of the Uniform Public Securities Law of the Ohio Revised Code, hereby certifies at the request of the Board of County Commissioners, that (a) the maximum maturity of the issue of \$630,000 of Bonds for the purpose of constructing a turn lane off of State Route 741 into the development known as The Estates of Keever Creek in the County, is twenty (20) years in accordance with the special assessment proceedings, and of notes issued in anticipation of such bonds, twenty (20) years and (b) the estimated life of said improvements exceeds five (5) years.



County Auditor

Dated: August 20th, 2019

Resolution

Number 19-1091

Adopted Date August 20, 2019

APPROVE REZONING APPLICATION OF RIDGEVIEW LLC, CHERYL KOLB, MANAGING MEMBER, (CASE # 2019-03) TO REZONE APPROXIMATELY 125.42 ACRES FROM LIGHT INDUSTRIAL ZONE "L1" TO SINGLE-FAMILY RESIDENTIAL ZONE "R1" IN TURTLECREEK AND UNION TOWNSHIPS

WHEREAS, this Board met this 20th day of August 2019, to consider the rezoning application of Ridgeview LLC, Cheryl Kolb, Managing Member, (Case # 2019-03) to rezone approximately 125.42 acres (Parcel ID 12212000012 & 12212000011) located at 2521 South US RT 42 in Turtlecreek and Union Townships from Light Industrial Zone "L1" to Single-Family Residential Zone "R1"; and

WHEREAS, this Board has considered the recommendation of the Regional Planning Commission and the Rural Zoning Commission and all those present to speak in favor of or in opposition to the rezoning application; and

NOW THEREFORE BE IT RESOLVED to approve the rezoning application of Ridgeview LLC, Cheryl Kolb, Managing Member, (Case # 2019-03) to rezone approximately 125.42 acres (Parcel ID 12212000012 & 12212000011) located at 2521 South US RT 42 in Turtlecreek and Union Townships from Light Industrial Zone "L1" to Single-Family Residential Zone "R1".

Mr. Young moved for adoption of the foregoing resolution being seconded by Mr. Grossmann. Upon call of the roll, the following vote resulted:

Mrs. Jones - yea
Mr. Grossmann - yea
Mr. Young - yea

Resolution adopted this day of July 2019.

BOARD OF COUNTY COMMISSIONERS



Tina Osborne, Clerk

tao/

cc: RPC
RZC
Rezoning file
Property Owner
Agent
Township Trustees

Resolution

Number 19-1092

Adopted Date August 20, 2019

APPROVE AMENDMENTS TO THE WARREN COUNTY THOROUGHFARE PLAN

WHEREAS, this Board met this 20^t day August 2019, in the Commissioners' Meeting Room to consider amendments to the Warren County Thoroughfare Plan; and

WHEREAS, this Board has considered the recommendation of the Regional Planning Commission and the County Engineer's Office and all those present to speak in favor of or in opposition to said amendment; and

NOW THEREFORE BE IT RESOLVED, to approve amendments to the Warren County Official Thoroughfare Plan; said amended plan attached hereto and made a part hereof.

Mr. Grossmann moved for adoption of the foregoing resolution being seconded by Mr. Young. Upon call of the roll, the following vote resulted:

Mrs. Jones - yea
Mr. Young - yea
Mr. Grossmann - yea

Resolution adopted this 20th day of August 2019.

BOARD OF COUNTY COMMISSIONERS



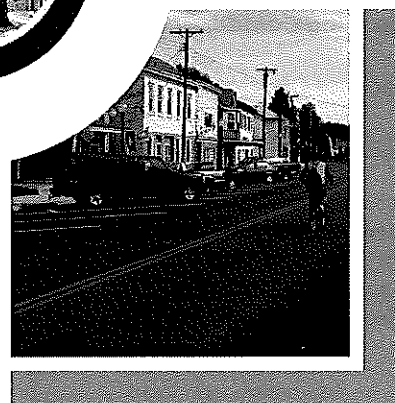
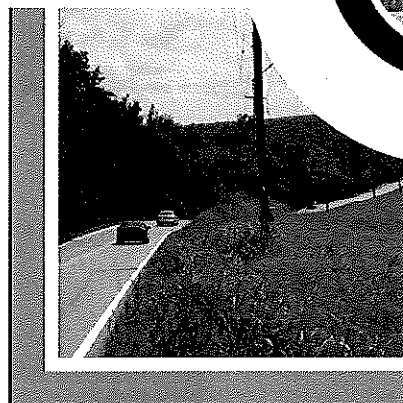
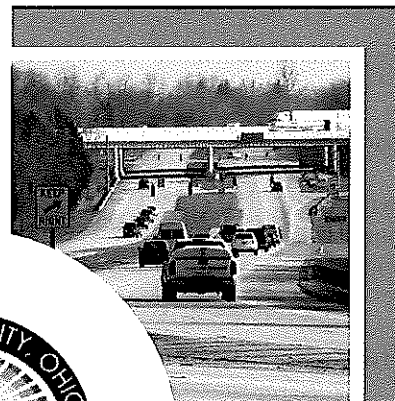
Tina Osborne, Clerk

/tao

cc: RPC
RZC (file)
Public Hearing file
Bruce McGary
Township Trustees
County Engineer



THOROUGHFARE



PLAN

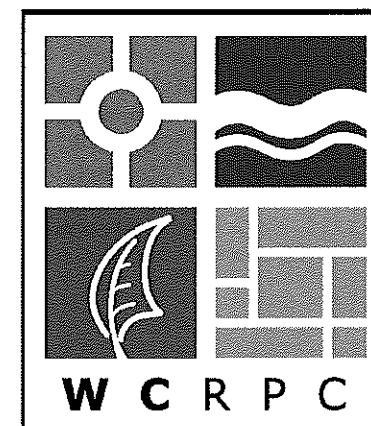
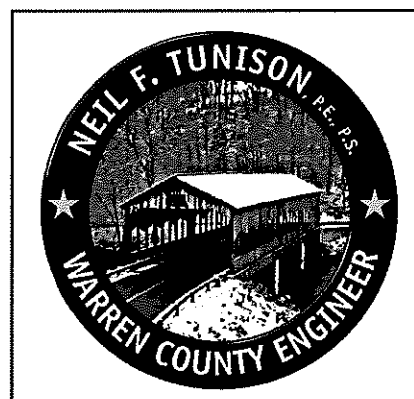




TABLE OF CONTENTS

Section 1 - Introduction	1-1
Authority to Plan.....	1-1
Purpose of the Warren County Official Thoroughfare Plan.....	1-1
Relationship with other Plans and Policies.....	1-2
Warren County Engineer's Transportation Improvement Plan (TIP).....	1-2
Warren County Transportation Improvement District (TID).....	1-3
OKI (Ohio Kentucky Indiana) Regional Transportation Plan.....	1-3
Lebanon-Warren County Airport Master Plan.....	1-4
OKI Regional Bicycle Plan.....	1-4
Township Comprehensive Plans.....	1-4
Special Area Plans.....	1-5
Municipal Plans.....	1-5
Southwest Warren County Transportation Study.....	1-6
Section 2 - Goals and Objectives	2-1
Thoroughfare Plan Goal Statement.....	2-1
Section 3 - Warren County Roadway Classifications	3-1
Thoroughfare Functional Classifications.....	3-1
Functional Classification of the County Thoroughfare Network.....	3-2
Section 4 - Future Roadway Improvements/Extensions/Alterations	4-1
Future Roadway Improvements/Extensions/Alterations.....	4-1
Notes.....	4-2
Appendix A - Typical Sections	A-1
Appendix B - Southwest Warren County Transportation Study	B-1
Appendix C - Hopkinsville 2010 Access Management Plan	C-1
Appendix D - 1996 Task Force Members	D-1
Appendix E - Past Records: Prior Thoroughfare Plan Amendments/Resolutions	E-1

LIST OF FIGURES

Figure 1.1 - Project Vicinity Map	1-6
Figure 3.1 - County Areas	3-4
Figure 3.2 - Roadway Classifications: Northwest Area	3-6
Figure 3.3 - Roadway Classifications: Northeast Area	3-7
Figure 3.4 - Roadway Classifications: West Area	3-8
Figure 3.5 - Roadway Classifications: East Area	3-9
Figure 3.6 - Roadway Classifications: Southwest Area	3-10
Figure 3.7 - Roadway Classifications: Southeast Area	3-11
Figure 3.8 - Warren County Pathway Map	3-12
Figure 4.1 - Union Road Roadway Map	4-4
Figure 4.2 - Wilkens Blvd Roadway Map	4-4
Figure 4.3 - Mason Montgomery Road/Brewer Road Roadway Map	4-4
Figure 4.4 - Shoemaker Road/Liberty - Keuter Road Roadway Map	4-4
Figure A.1 - Typical Section, Primary Arterial - Rural	A-2
Figure A.2 - Typical Section, Primary & Secondary Arterial - Urban	A-3
Figure A.3 - Typical Section, Secondary Arterial - Rural	A-4
Figure A.4 - Typical Section, Frontage Road - Residential/Commercial	A-5
Figure A.5 - Typical Section, Primary Collector/Distributor	A-6
Figure A.6 - Typical Section, Major Collector/Distributor - Rural	A-7
Figure A.7 - Typical Section, Collector - Residential Urban	A-8
Figure A.8 - Typical Section, Collector - Enhanced Urban Collector	A-9
Figure A.9 - Typical Section, Collector - Residential Rural	A-10
Figure A.10 - Typical Section, Collector - Commercial/Industrial	A-11
Figure A.11 - Typical Section, Local Street - Residential/Rural	A-12
Figure A.12 - Typical Section, Local Subdivision Street - Residential/Rural	A-13
Figure A.13 - Typical Section, Local Subdivision Street - Residential/Urban	A-14
Figure B.1 - Southwest Warren County Transportation Study High Priority Map	B-2
Figure B.2 - Southwest Warren County Transportation Study Medium Priority Map	B-3
Figure B.3 - Southwest Warren County Transportation Study Low Priority Map	B-4



problems exist. TIP's are generally short-range in nature and ideally are updated on a recurring basis to assure that transportation needs are being met. The Warren County Engineer has established a TIP to address transportation deficiencies for roadways under the jurisdiction of the Engineer's office.

Warren County Transportation Improvement District (TID)

The Warren County TID is a governmental entity appointed by the Warren County Board of County Commissioners. The TID possesses general powers to manage and construct highway-related projects with the purpose to improve the County's transportation system.

OKI (Ohio Kentucky Indiana) Regional Transportation Plan

The OKI 2030 Regional Transportation Plan Update fulfills the region's requirement that all transportation programs in urban areas exceeding 50,000 in population result from a regional transportation plan, based on a continuing, comprehensive transportation planning process carried out cooperatively between state and local communities. Warren County is a member entity of the OKI Metropolitan Planning Organization (MPO), and is embraced within the scope of a regional plan.

The regional plan enables the development of a regional inter-modal transportation system that expands travel options and improves and maintains transportation infrastructure in order to enhance the mobility of people and goods, and improve air quality.

Recommendations consist of major investment studies, including the I-71 corridor transit service expansion and improvement, Intelligent Transportation Systems, rideshare programs, bicycle and pedestrian projects, traffic operation improvement, and highway capacity expansions.

Projects arising from the regional transportation plan can, at the request of the local sponsor, move forward toward implementation through a process known as the Transportation Improvement Program, or TIP.

The TIP is the compilation of all publicly-assisted transportation projects, including both highway and transit elements, constrained to available funding levels and prioritized by need. Inclusion in the TIP is a prerequisite for Federal funding assistance. Upon adoption by the OKI policy board, the TIP becomes a policy document that directs the flow of transportation improvements within the region.

Lebanon-Warren County Airport Master Plan

The Warren County Airport Authority, under the direction of the Warren County Board of Commissioners, completed an airport master plan in 2005 for the Lebanon-Warren County Airport. The master plan was charged with identifying the overall land and facility requirements that will ensure the airport's long-term viability, from which a 10-year development plan was prepared that is technically correct, environmentally and financially sound, implementable, and responsive to the needs of the airport users as well as the concerns of the public.

OKI Regional Bicycle Plan

The OKI Regional Bicycle Plan is a blueprint for the development of OKI's eight-county bicycle transportation system. Under the requirements of the Safe, Accountable, Flexible, Efficient Transportation Act (SAFETEA-LU) of 2005, metropolitan planning organizations such as OKI are required to develop transportation plans that include bicycle transportation.

Warren County contains two of the major bicycle transportation corridors within the system: the Great Miami and the Little Miami Scenic Bike Paths. The Great Miami Bike Path will connect Cincinnati and Dayton. More than 28 miles of this trail is already completed from Dayton to just south of Franklin, in Warren County. The Little Miami Scenic Bike Path connects Springfield and Cincinnati. A key link in the Warren County portion of the Little Miami Scenic Bike Path, between Oregonia Road and Corwin Road, was completed in 1996. The Little Miami Scenic Bike Path extends for more than 72 miles.

In addition to considering individual bicycle projects, the Regional Bicycle Plan also discusses the need for roadway improvements to facilitate bicycle usage including bike lanes, wide outside lanes, paved shoulders, and bike paths. It also addresses additional travel needs including access to bridges and viaducts, bicycle parking (racks and lockers), improvements to railroad crossings, provision of bicycle-safe grates and bicycle-actuated traffic signals, and roadway maintenance. The plan presents recommendations including funding priorities for bicycle corridors, the need for safety and educational programs for bicyclists, and bicycle commute services.

Township Comprehensive Plans

WCRPC is currently in the process of updating its land use component of the Warren County Comprehensive Plan. The land use component was last updated in 2007 for 5 (of 11 total) townships within Warren County which utilize county zoning. More recently WCRPC has worked



SECTION 2 Goals and Objectives

Thoroughfare Plan Goal Statement

The 1996 Task Force identified the following issues as being important to consider:

- Connections with other modes of transportation (intermodalism),
- Meeting current and future needs,
- Safety,
- Convenience,
- Economic growth,
- Sensitivity to environmental concerns,
- The efficient use of limited financial resources or "sustainability,"
- Connecting people and goods with markets and destinations both inside and outside Warren County, and
- Maintaining the integrity of the existing highway system through limitations on the number of curb cuts, the effective use of signalization, and signage.

Using these elements, the Task Force drafted the following goal statement:

To develop a safe, efficient, and environmentally-sound transportation system for the movement of people and goods. Such a system will provide for economic growth and recreational opportunities through a convenient, accessible, and intermodal system designed to meet the current and future transportation needs of Warren County.

To support this goal, a number of objectives were developed. In turn, these objectives are supported by a series of strategy statements.

Objective 1: Transportation Study - Promote the design, construction, and maintenance of new and existing transportation systems and facilities within Warren County.

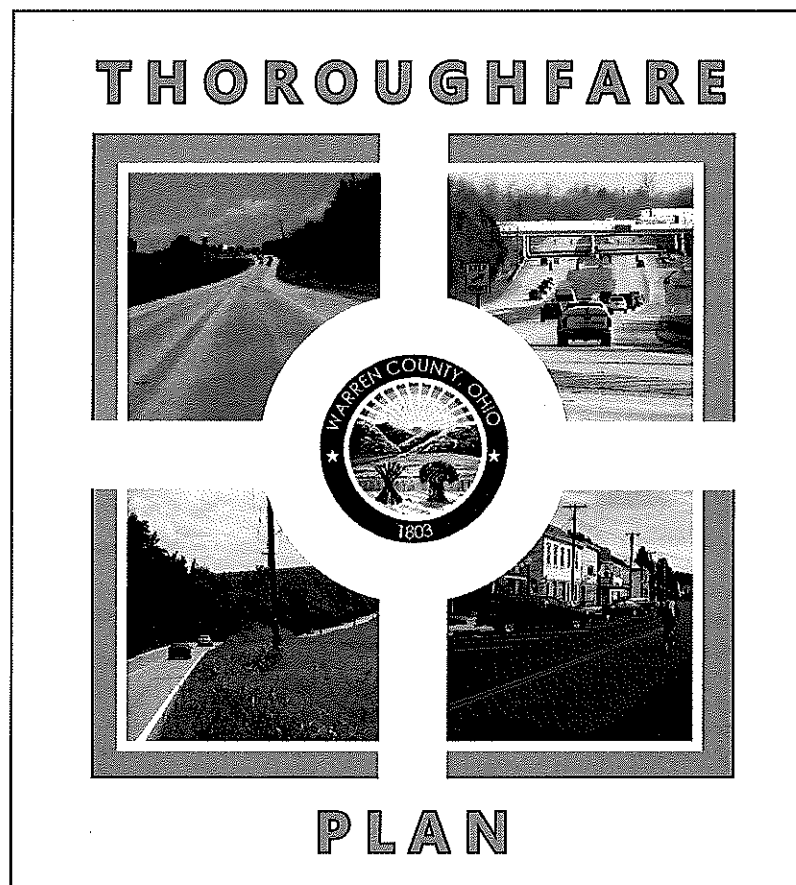
Strategies:

- Construct highway improvements while giving consideration to design issues such as minimum sight distances, and so on.
- Ensure proper turn movement and channelization on arterials and collectors.
- Integrate sidewalks and bikeways to safely accommodate pedestrians and bicyclists.
- Identify high impact areas and develop initiatives to mitigate safety problems in those areas.

Objective 2: Proactiveness - Develop an action plan to implement the recommendations of the thoroughfare plan in a manner to meet existing and long-range needs.

Strategies:

- Protect capacity by developing and implementing access standards.
- Encourage economic development in areas where the thoroughfare system already exists, where proposed thoroughfares are projected, or where limited expansion is required.
- Encourage land use patterns along arterials and collectors that do not degrade carrying capacity.
- Develop criterion to evaluate proposed developments and their impact on existing proposed thoroughfares.
- Preserve rights-of-way for future thoroughfare expansion and continuation on identified corridor extensions.
- Encourage dialogue between the county, municipalities, and the private sector to coordinate thoroughfare improvements and employment opportunities in appropriate areas.
- Identify a future functional classification system and steps necessary to implement the system.
- Identify thoroughfare corridors that do not interfere with sensitive environmental areas.



SECTION 3
Warren County Roadway Classifications
and Pathway Map



FIGURE 3.1

County Areas

been defined in the functional classification system for the Warren County network are shown in Appendix A. The standards depicted in the diagrams were designed with specific relationship to Warren County thoroughfares as relates to function and location within the network. As such, there are design standards for thoroughfares in urban versus rural locational settings, as well as distinctions for residential versus non-residential use development locations. Minimum right-of-way widths, among other design factors, are specified in the cross-section diagrams for each thoroughfare type and use setting, with incorporation of intermodal provisions for bicyclists and pedestrians. These cross-section diagrams were developed to encourage the preservation of adequate rights-of-way for various road types throughout the county. It should be noted that for developments designed in a neo-traditional or new urbanism style, the standards shown in the cross-section diagrams may be varied at the discretion of the Warren County Engineer's Office.

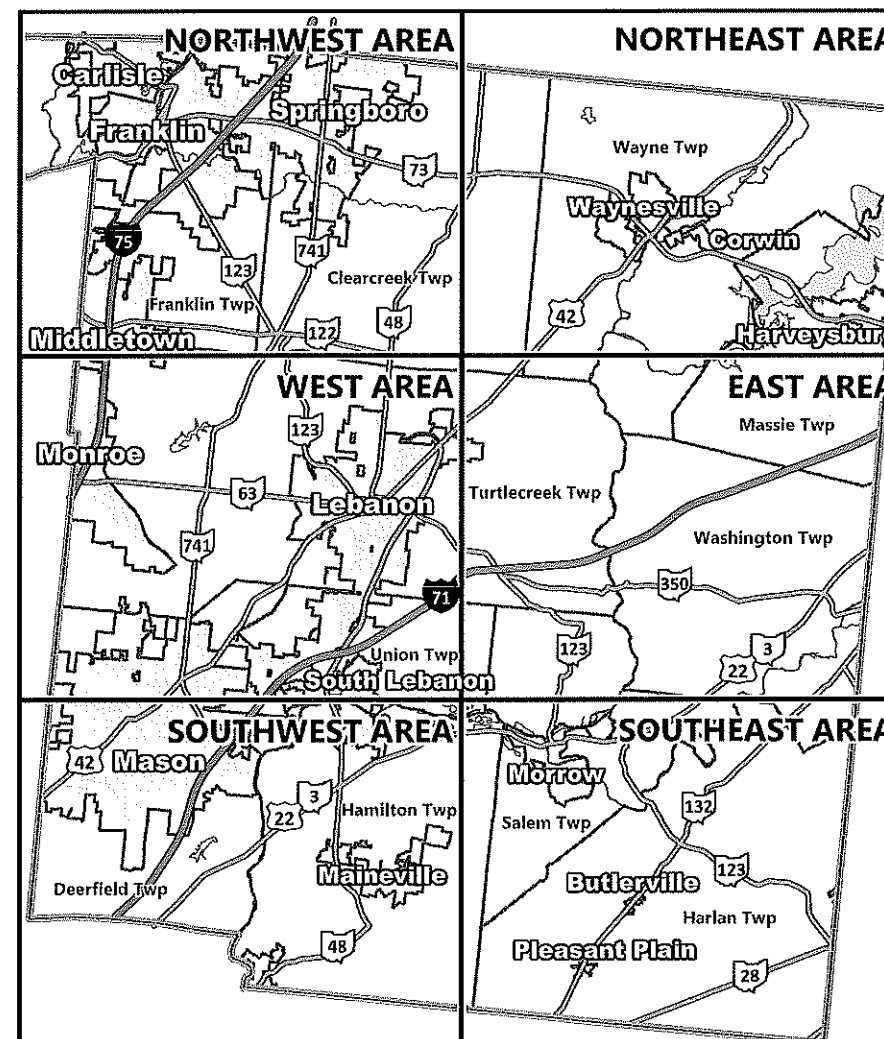




FIGURE 3.3

Functional Classifications:
Northeast Area

Legend

- COUNTY BOUNDARIES
- POLITICAL SUBDIVISIONS
- LOCAL SUBDIVISION STREETS
- MUNICIPALITIES
- TOWNSHIPS

FUNCTIONAL CLASSIFICATIONS

Existing

- Collector
- Interstate
- Local Road
- Major Collector/Distributor
- Primary Arterial
- Primary Collector/Distributor
- Secondary Arterial
- Vacation

Future

- Collector
- Interstate
- Local Road
- Major Collector/Distributor
- Primary Arterial
- Primary Collector/Distributor
- Secondary Arterial
- Vacation

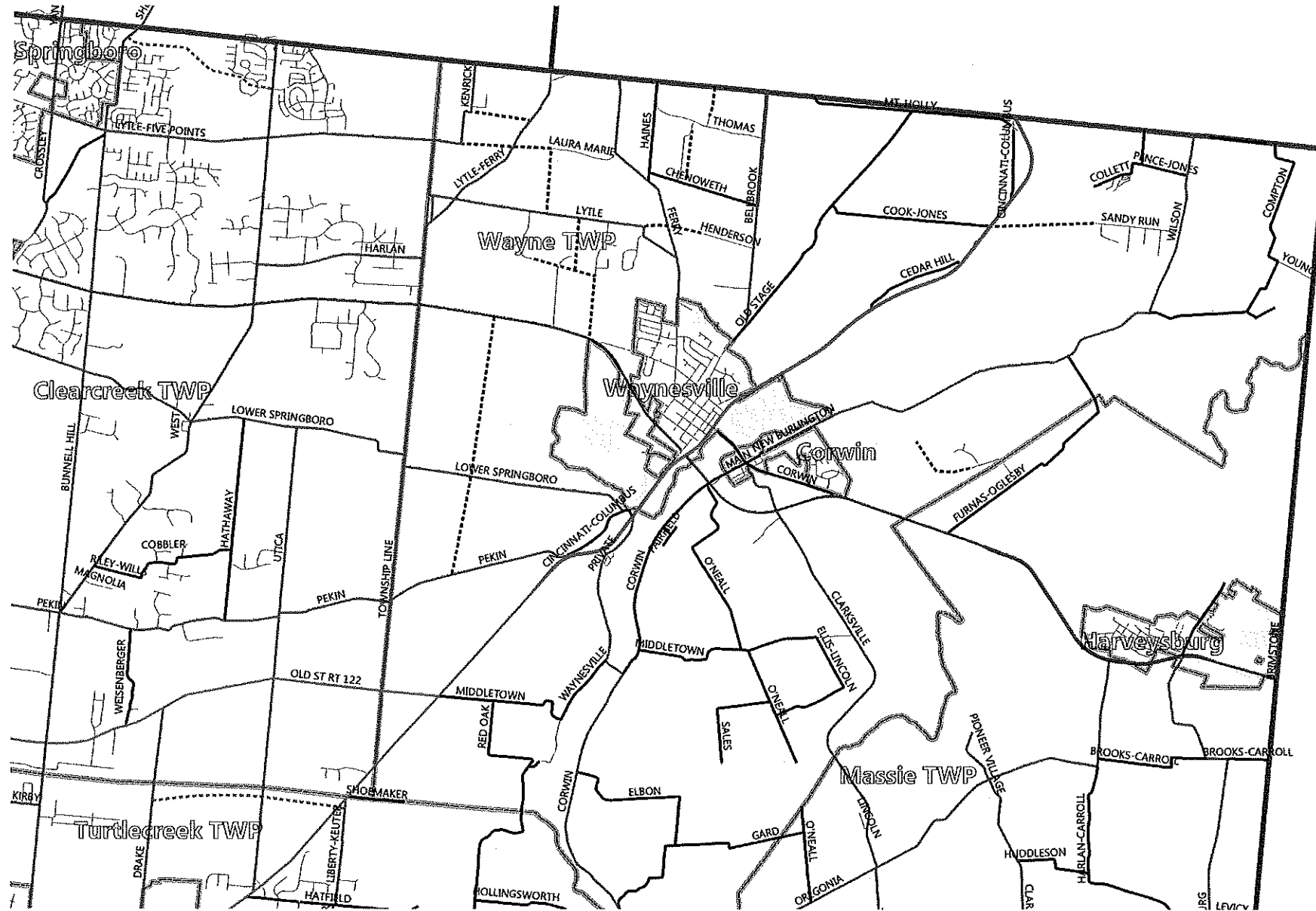




FIGURE 3.5

Functional Classifications:
East Area

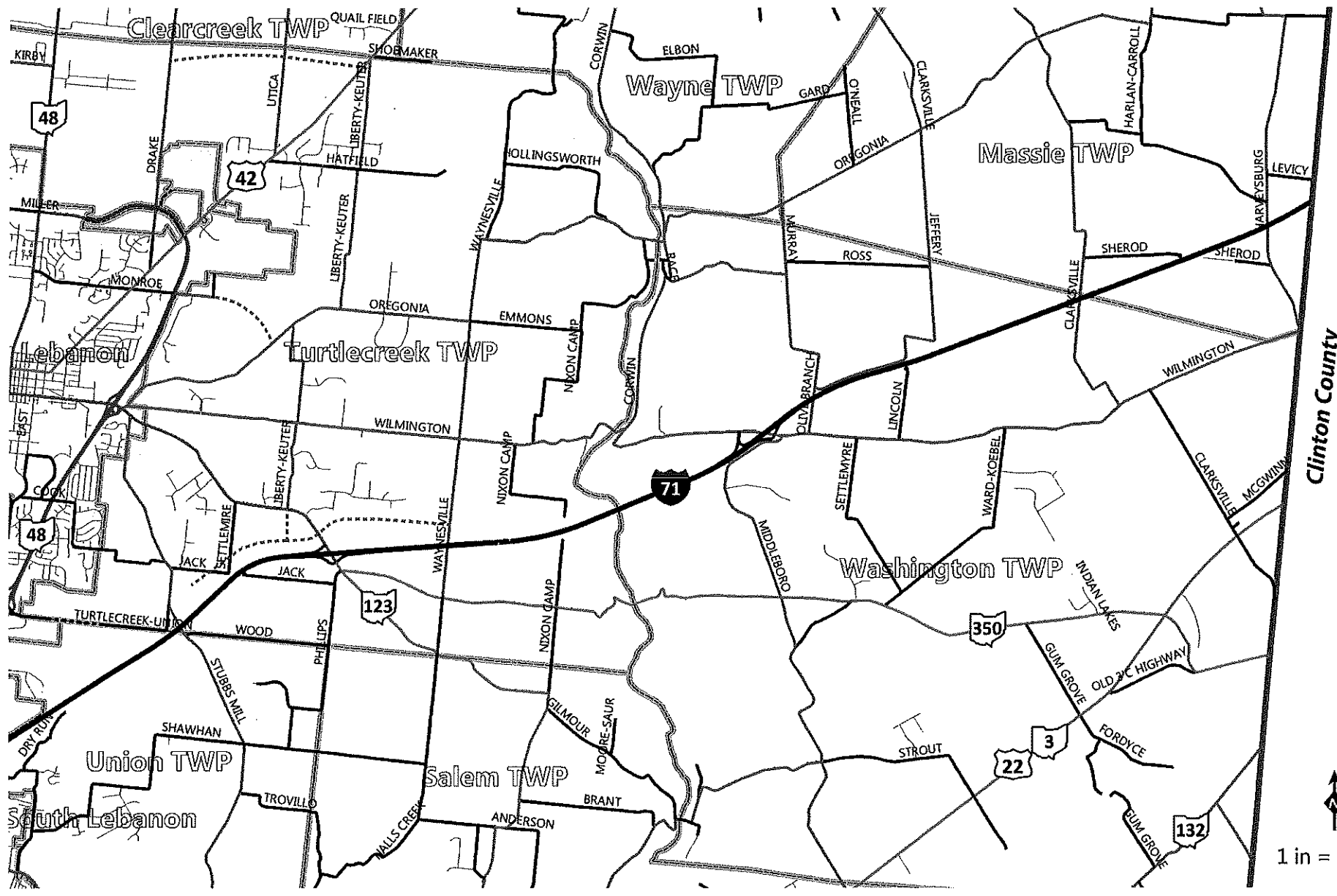
Legend

- COUNTY BOUNDARIES
- POLITICAL SUBDIVISIONS
- LOCAL SUBDIVISION STREETS
- MUNICIPALITIES
- TOWNSHIPS

FUNCTIONAL CLASSIFICATIONS

- Existing
- Collector
 - Interstate
 - Local Road
 - Major Collector/Distributor
 - Primary Arterial
 - Primary Collector/Distributor
 - Secondary Arterial
 - Vacation

- Future
- Collector
 - Interstate
 - Local Road
 - Major Collector/Distributor
 - Primary Arterial
 - Primary Collector/Distributor
 - Secondary Arterial
 - Vacation



N

1 in = 1 mile



FIGURE 3.7

**Roadway Classifications:
Southeast Area**

Legend

- COUNTY BOUNDARIES
- POLITICAL SUBDIVISIONS
- LOCAL SUBDIVISION STREETS
- MUNICIPALITIES
- TOWNSHIPS

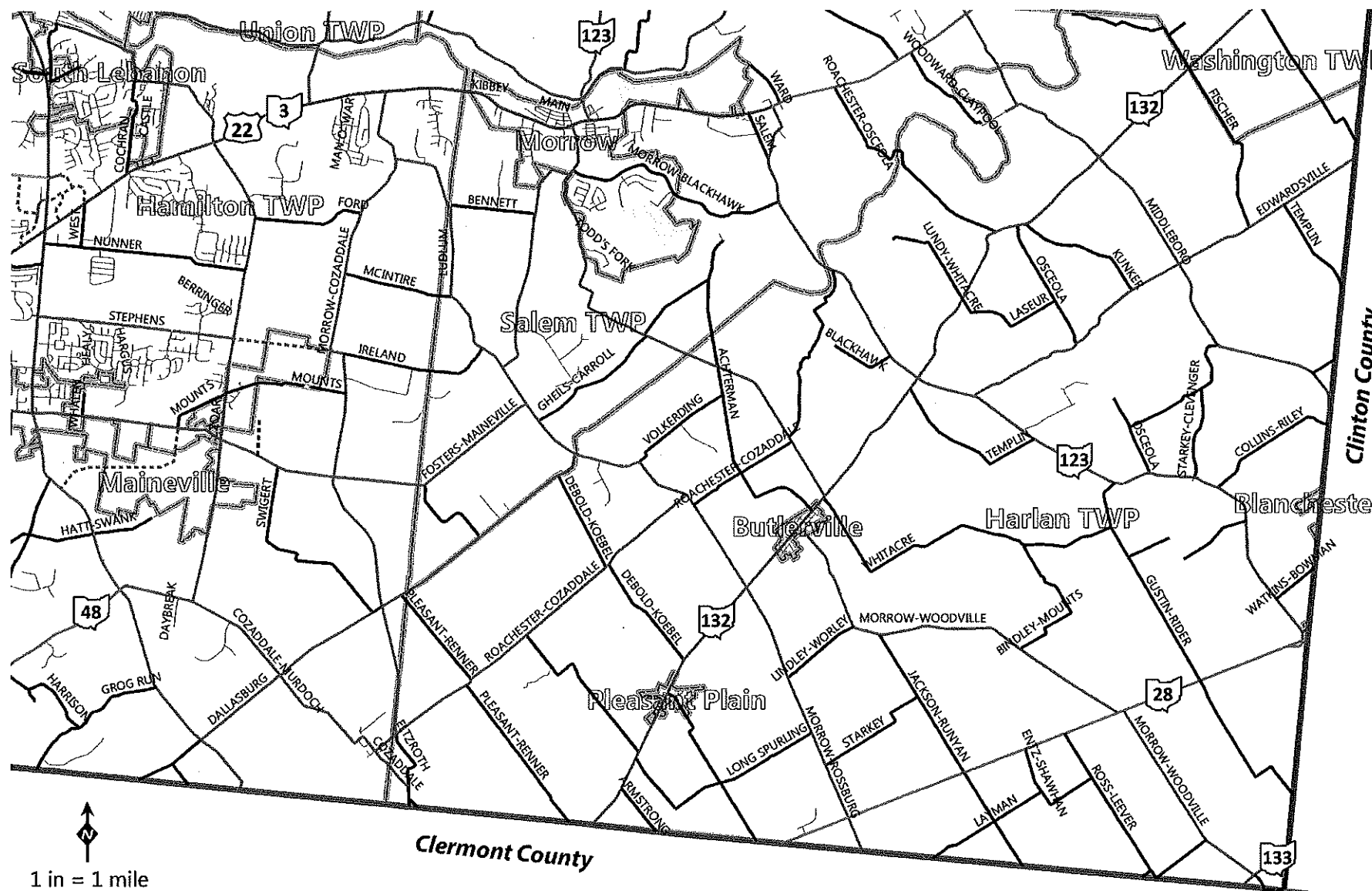
FUNCTIONAL CLASSIFICATIONS

Existing

- Collector
- Interstate
- Local Road
- Major Collector/Distributor
- Primary Arterial
- Primary Collector/Distributor
- Secondary Arterial
- Vacation

Future

- Collector
- Interstate
- Local Road
- Major Collector/Distributor
- Primary Arterial
- Primary Collector/Distributor
- Secondary Arterial
- Vacation





SECTION 4

Future Roadway Improvements/Extensions/Alterations

Future Roadway Improvements/Extensions/Alterations

The Thoroughfare Plan's future roadway improvements/extensions/alterations are comprised of the future roads represented by the lines labeled as "future" on the Thoroughfare Plan Functional Classification Maps previously shown in Section 3, and the improvements listed in this Section:

- SR 63 Improvements - Widen and improve SR 63 to five lanes (two travel lanes in each direction with a center turn-lane and/or median). These improvements should be designed to increase safety and reliability, reduce vehicle delay, manage access, and respond to growth in the years to come. Improvements should also be designed to be context-sensitive in relation to future development patterns and pedestrians. The objective is a safe, accessible, attractive, and unique corridor that encourages a culture of walking and biking.
- New King Avenue Bridge - Construct a new bridge crossing the Little Miami River that replaces the existing King Avenue Bridge. This is required to improve traffic safety; improve emergency service response times; and maintain good traffic-flow in response to planned growth within the area. The new bridge should be designed to correct major deficiencies including load-carrying capacity; deficient deck geometry; deficient alignment approaching the current bridge; and to improve access for truck-traffic. An underpass for the Little Miami River Trail will also be needed and bike lanes should be added to the bridge. These improvements will directly benefit residents through reduction in travel-times and improved access to employment opportunities, community services, community facilities, and daily needs.
- Southwest Warren County Transportation Improvements shown in Appendix B.

Notes:

1. Public improvements to re-align/re-profile Mason-Montgomery Road and Brewer Road necessary with the Brewer Road extension (Figure 4.3).
2. Potential for Development Assessment

NORTHWEST

- Collector Road - Between SR 123 and SR 741 north of SR 122.
- Collector Road - SR 48 to Bunnel Hill Road
- Collector Road - Shaker Road to Robinson-Vail Road
- Collector Road - Hendrickson Road to Greentree Road
- Bechtel Drive - Extend to Hendrickson Road.
- Hendrickson Road (Collector) - Shaker Road to SR 123
- Lynn Drive - Extend to Magellan Way extension
- Magellan Way - Extend to Bechtel Drive extension
- Manchester Road (Collector) - Robinson Vail to SR 123
- Robinson-Vail @ SR 123 - Cul-de-sac Robinson-Vail Road south of SR 123 in conjunction with an extension of Manchester Road to SR 123
- Robinson-Vail Road - Extend the road south of SR 122 to Franklin Hunter Park
- Wilson Farm Boulevard (Collector) - Wilson Farms Subdivision to SR 123

NORTHEAST

- Kenrick Road (Collector) - Lytle-Five Points to northern County border
- Collector Road - Drake Road to SR 42 south of Old SR 122 and align intersection to Shoemaker Road and Liberty-Keuter Road



FIGURE 4.1 - Union Road

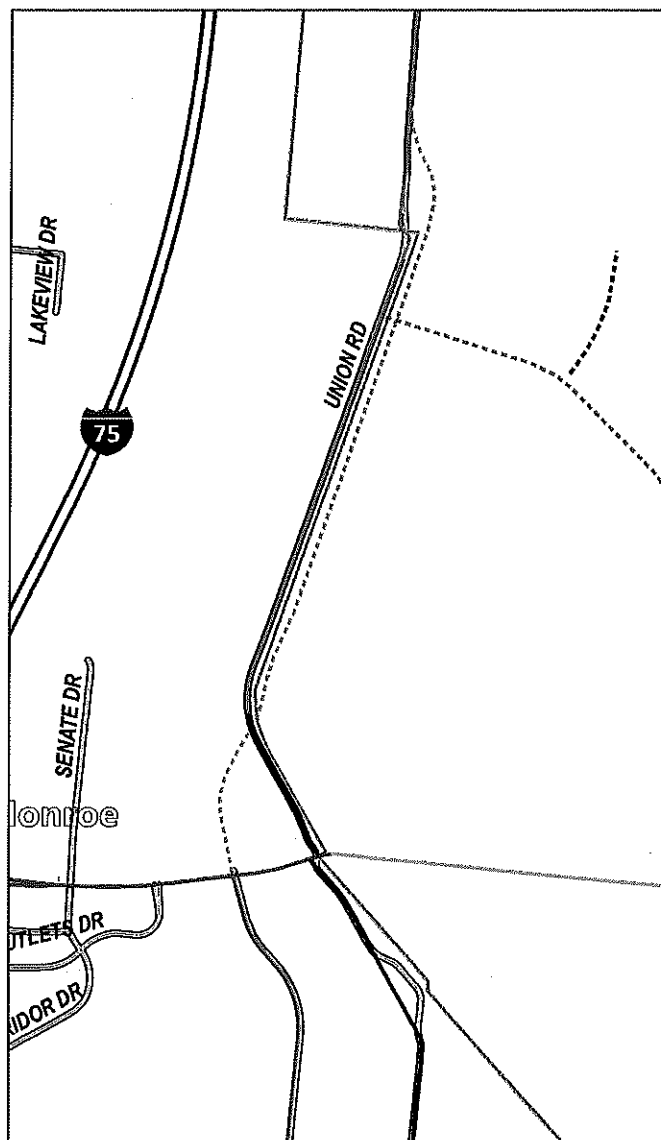


FIGURE 4.2 - Wilkens Blvd

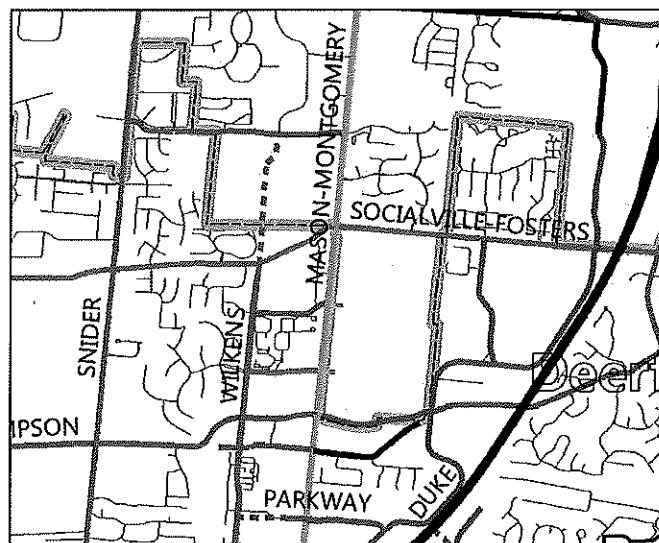


FIGURE 4.3 - Mason Montgomery/Brewer

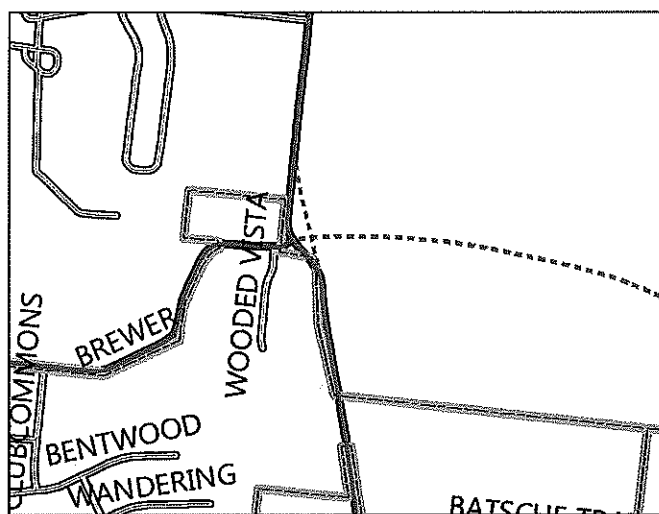
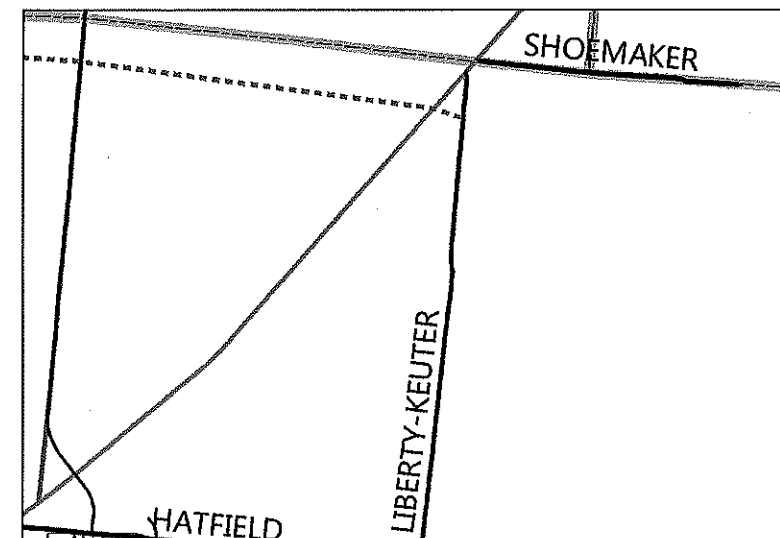
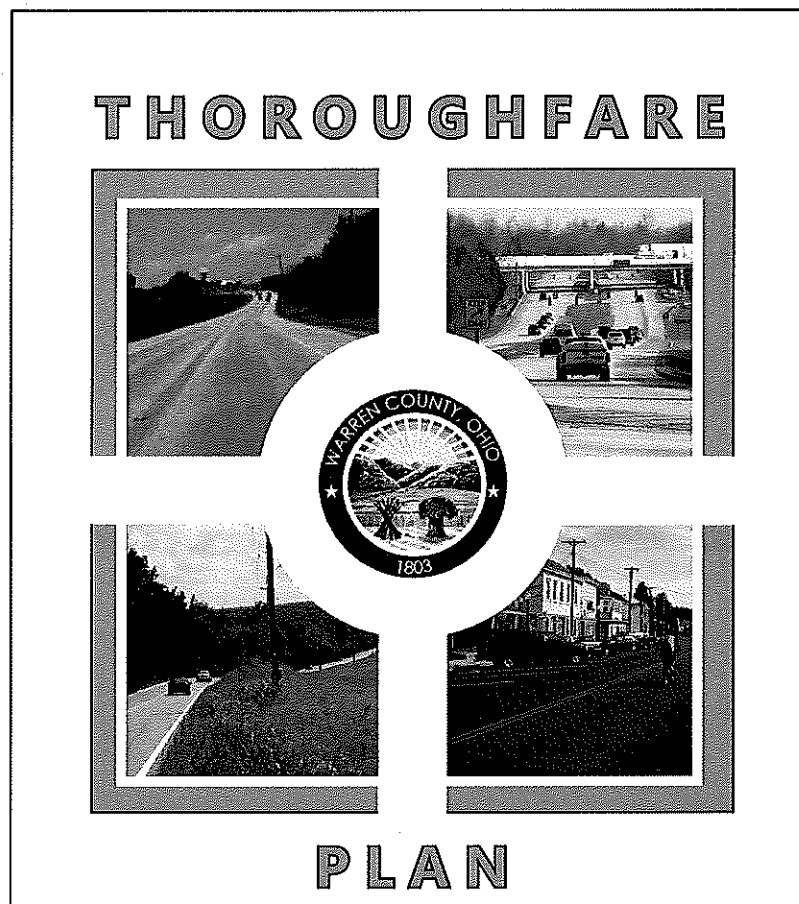


FIGURE 4.4 - Shoemaker Road/Liberty-Keuter



Legend

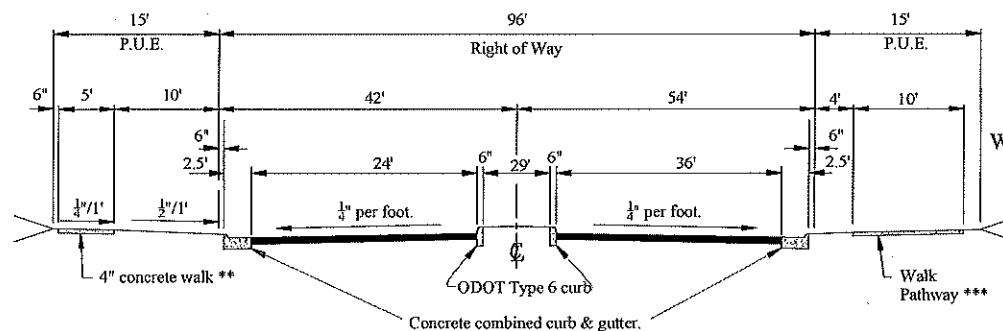
FUNCTIONAL CLASSIFICATIONS	
Existing	Future
Collector	Collector
Interstate	Interstate
Local Road	Local Road
Major Collector/Distributor	Major Collector/Distributor
Primary Arterial	Primary Arterial
Primary Collector/Distributor	Primary Collector/Distributor
Secondary Arterial	Secondary Arterial
Vacation	Vacation



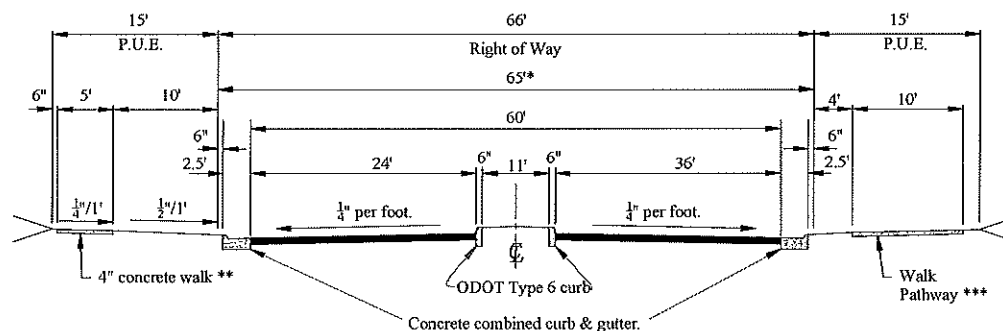
APPENDIX A
Typical Sections



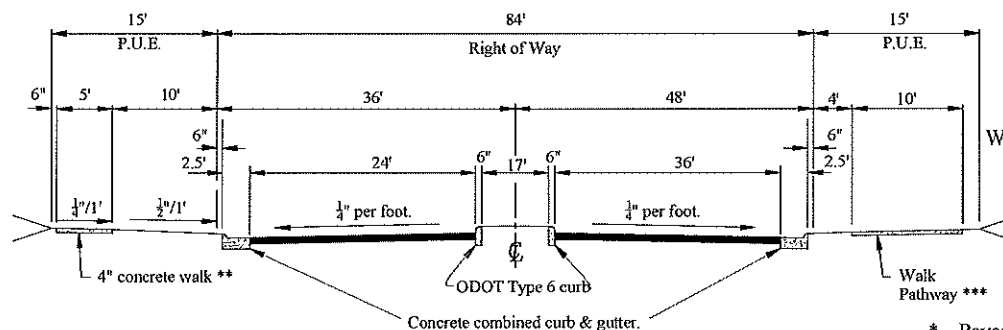
FIGURE A.2
Typical Section, Primary and Secondary Arterial - Urban



Typical Section
Secondary Arterial - Urban
Within 450' of Right of Way of roads classified as Major Collectors/Distributors or above.



Typical Section
Primary and Secondary Arterial - Urban
Other than above.



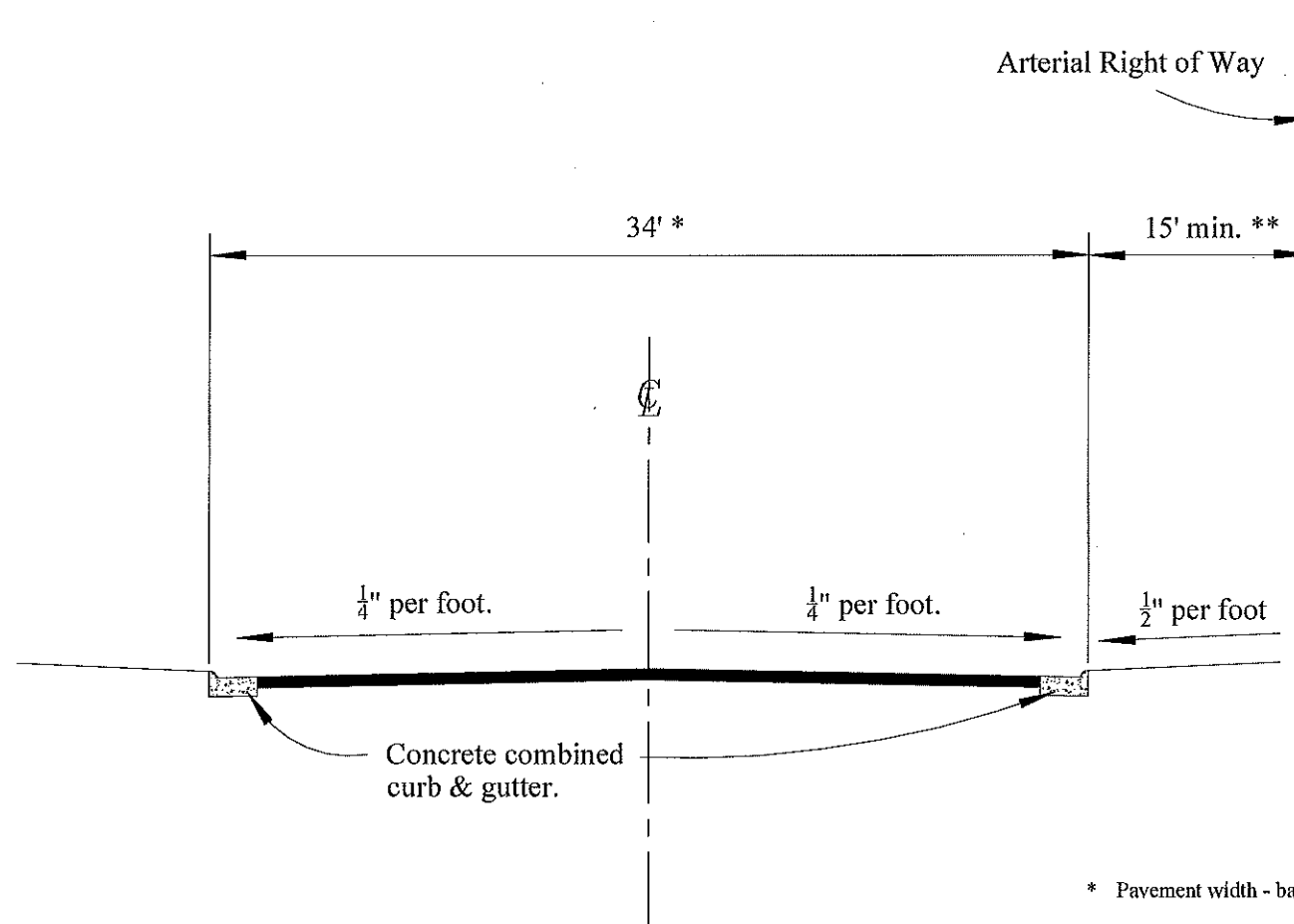
Typical Section
Primary and Secondary Arterial - Urban
Within 350' of Right of Way of roads classified as Collectors.



- * Pavement width - back of curb, to back of curb.
- ** As per Subdivision Regulations.
- *** As per Pathway Map/Subdivision Regulations.



FIGURE A.4
Typical Section, Frontage Road - Residential/Commercial/Industrial



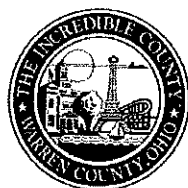
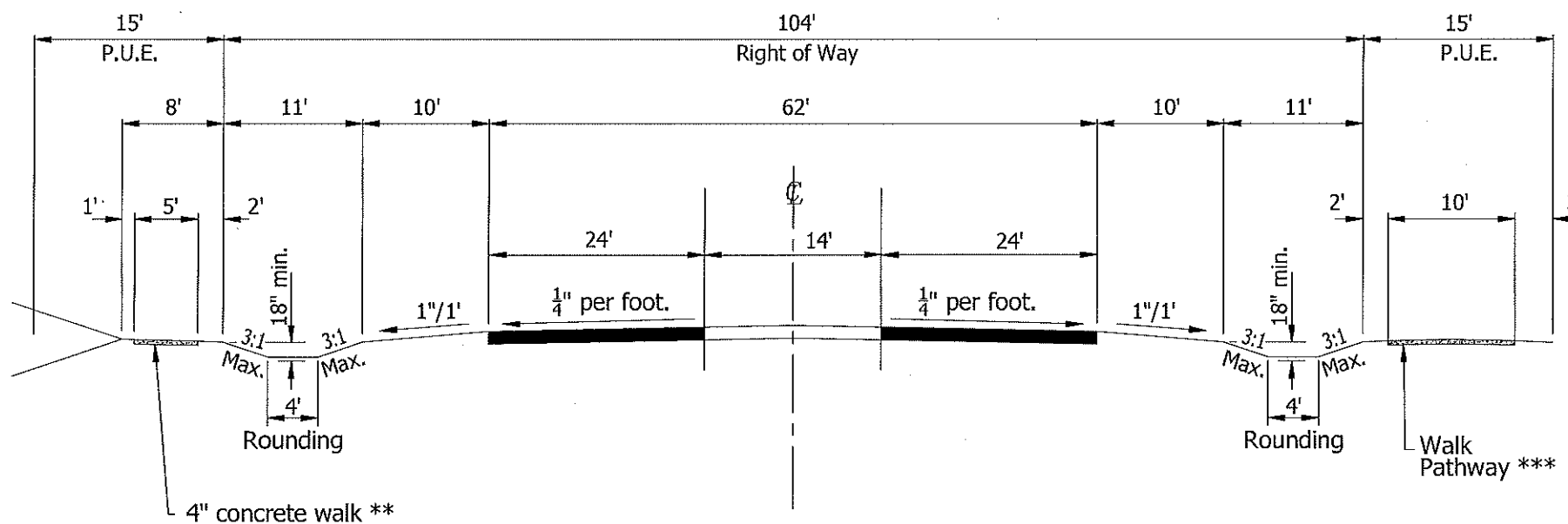
* Pavement width - back of curb, to back of curb.

** TBD - Per traffic impact study near drives.





FIGURE A.6
Typical Section, Major Collector/Distributor - Rural

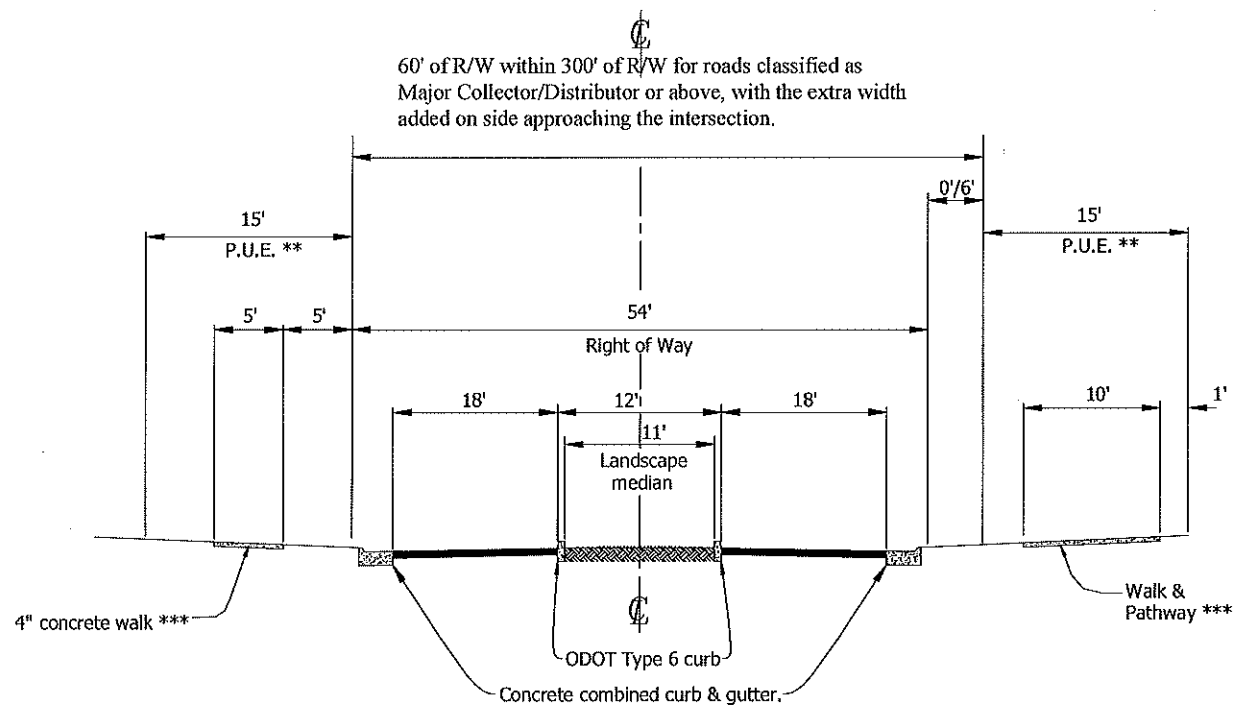


** As per Subdivision Regulations.

*** Or as per Pathway Map/Subdivision Regulations.



FIGURE A.8
Typical Section, Collector - Enhanced Urban

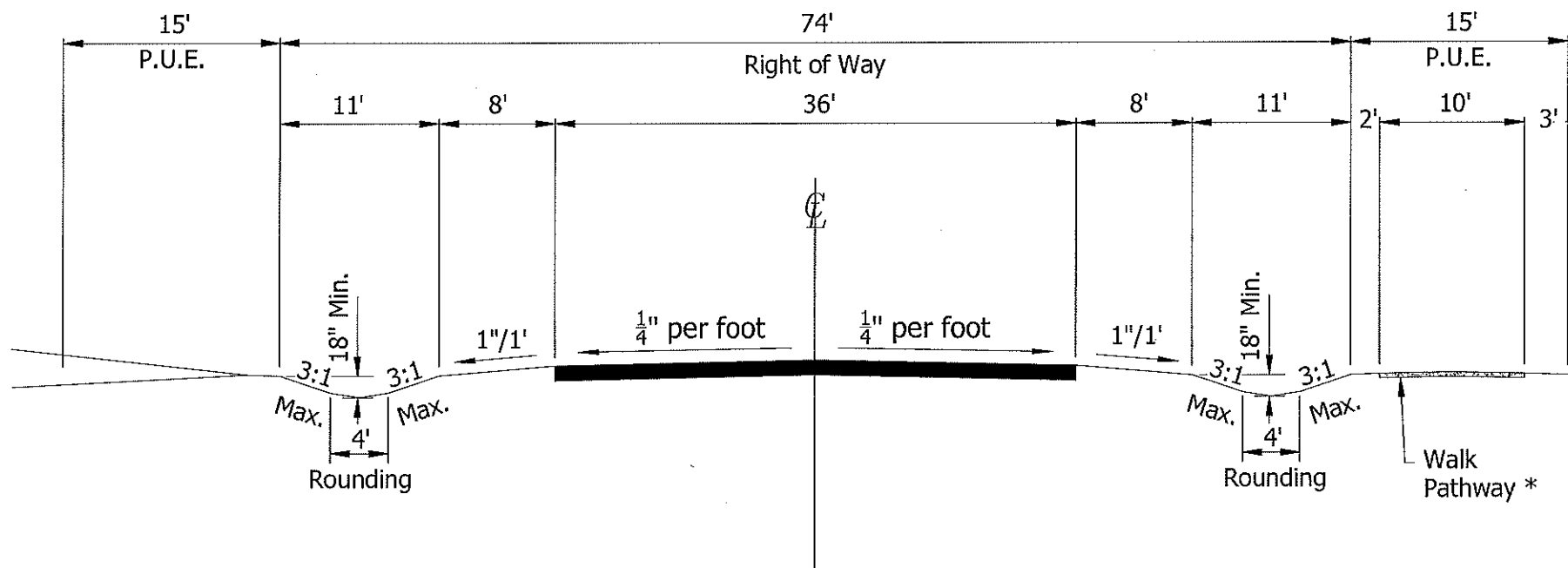


** Public Utility Easement begins 6" behind back of curb.

*** As per Pathway Map/Subdivision Regulations.



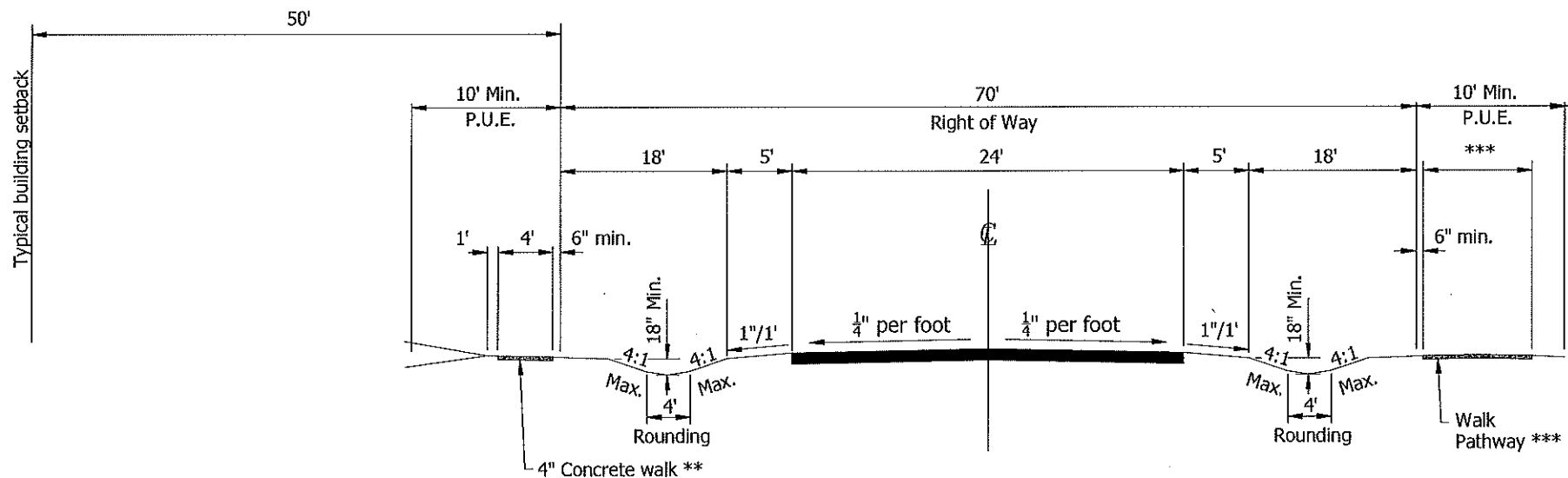
FIGURE A.10
Typical Section, Collector - Commercial/Industrial



* Or as Pathway Map/Subdivision Regulations

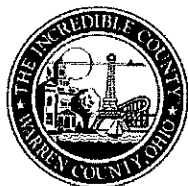


FIGURE A.12
Typical Section, Local Subdivision Street - Residential/Rural



** As per Subdivision Regulations.

*** As per Pathway Map/Subdivision Regulations.
(if applicable, width & location TBD)



APPENDIX B
Southwest Warren County Transportation Study

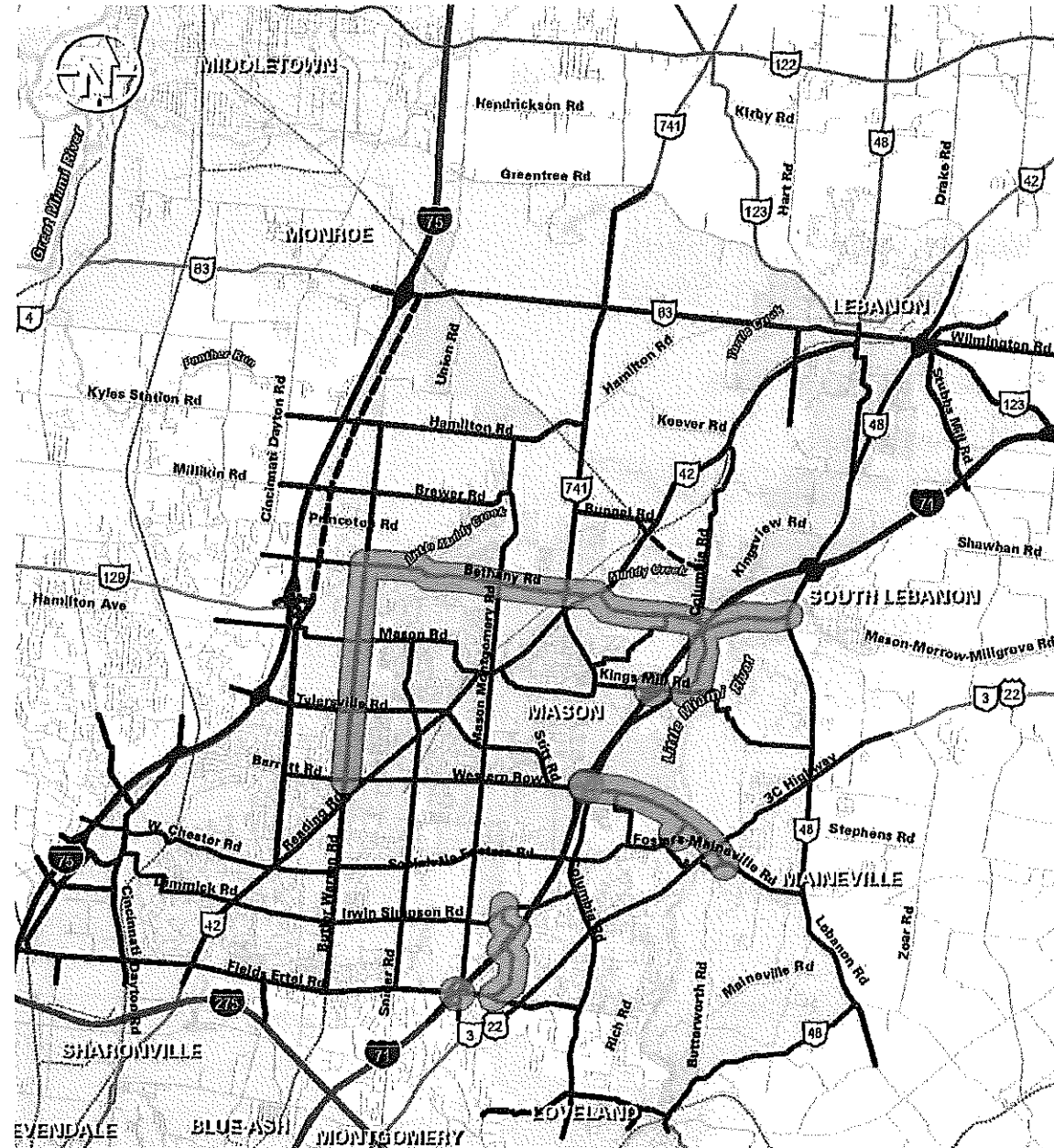
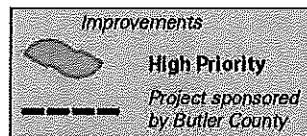
FIGURE B.1

**Southwest Warren County
 Transportation Study**

High Priority Projects

High Priority : \$145.5 Million

- Fields Ertel/Mason Montgomery/I-71 Interchange Feasibility Study
- Bethany and Mason-Morrow-Millgrove Roads Improvements
- Waterstone Connector
- Upgrade Western Row Road Interchange to a Full Interchange
- Western Row Road Extension (includes LMR Crossing)
- Upgrade SR 741 Interchange
- Widen Columbia Road between Kings Mill and Mason-Morrow- Millgrove Roads
- Widen Butler Warren Road between Barrett and Bethany Roads



APPENDIX B
Southwest Warren County Transportation Study

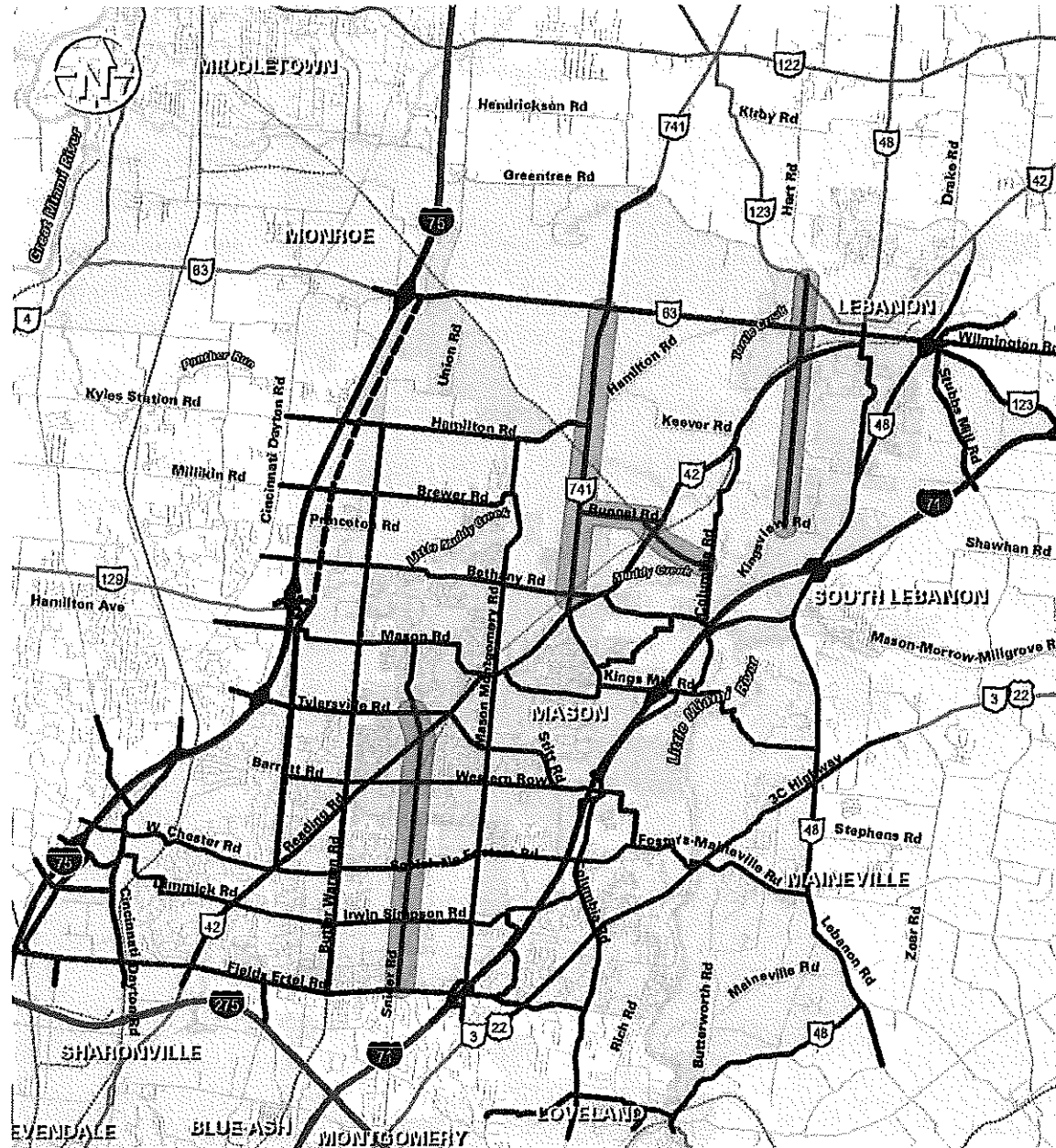
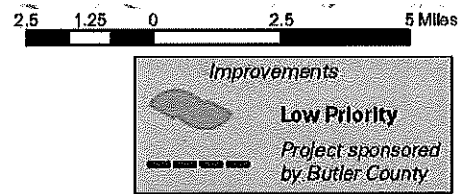
FIGURE B.3

**Southwest Warren County
 Transportation Study**

Low Priority Projects

Low Priority : \$52.4 Million

- Widen Snider Road between Fields Ertel and Tylersville Roads
- Glosser and Bunnell Roads Improvements
- Widen SR 741 between SR 63 and US 42
- Bus Circulator System





APPENDIX E
Past Records: Prior Thoroughfare Plan
Amendments/Resolutions

RESOLUTION No. 8-96

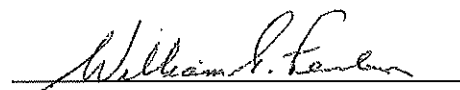
UPDATED WARREN COUNTY OFFICIAL THOROUGHFARE PLAN

WHEREAS, as a statutory requirement for reviewing plats of subdivisions, the Warren County Regional Planning Commission has adopted a plan for major streets or highways of Warren County known as the Warren County Official Thoroughfare Plan; and

WHEREAS, Ohio Revised Code, Section 711.10 requires a public hearing as a prerequisite to adoption or amendment of such plan; and


WHEREAS, public hearings were held by the Warren County Regional Planning Commission on April 9, 1996, May 7, 1996, and July 9, 1996, to update the Warren County Official Thoroughfare Plan; and

NOW THEREFORE BE IT RESOLVED, that the Warren County Regional Planning Commission adopts the updated Warren County Official Thoroughfare Plan.



William G. Fenton
Warren County Regional Planning Commission

ATTEST:



Robert D. Price, Executive Director
Warren County Regional Planning Commission

Date: July 9, 1996



Resolution 3-03 (Page 2)

1. Functional Classification Map (Figure #4.1), including;

- a. Extension of Relocated Irwin-Simpson Road, between proposed Wilkens Boulevard (aka Wildcat Drive) and existing Irwin-Simpson Road, in Deerfield Township, classified as an Enhanced Urban Class Collector (Figure #4.91), with a 54 foot right-of-way width, projected as a short range (0-5 year) improvement need; and
- b. Extension of Grandin Road, between State Route 48 and U.S. Route 22-3, in Hamilton Township, classified as an Urban Class Residential Collector (Figure #4.9), with a 42 foot right-of-way width, projected as a short range (0-5 year) improvement need; and

An additional north-south Residential Urban Class Collector road, approximately 1,200 feet west of State Route 48, between Grandin Road and U.S. Route 22-3, as well as an east-west road (same classification), between existing Grandin Road and U.S. Route 22-3, with an intersection location along State Route 48, subject to Ohio Department of Transportation (ODOT) approval; and

Access management will be needed throughout this proposed street grid; and

- c. Extension of Shaker/Dearth Road, between State Routes 122 and 123, in Franklin Township, classified as an Urban Class Residential Collector (Figure #4.9), with a 42 foot right-of-way width, projected as a long range (11-20 year) improvement need; and (Revised April 2007)
2. Warren County Bikeway Map (Figure #4.2), in conformance with the Miami to Miami Connection Feasibility Study (October, 2002) and the City of Mason Bicycle and Pedestrian Way Master Plan (August, 2001); and
3. Typical Street Sections (Figures #4.2 through 4.14), as applicable, in conformance with the above; and

WHEREAS, the RPC Chairman directed on February 11, 2003 that a Special RPC Meeting, per Article V (Meetings) of the Resolution of Cooperation of the Warren County Regional Planning Commission (aka RPC Bylaws), be called on March 11, 2003, directing that all appropriate arrangements be made, including notification and advertising; and

WHEREAS, the RPC members were mailed a notice of the Special RPC Meeting on February 12, 2003, with a Legal Notice of a Public Hearing being duly published in the newspaper of general circulation on February 27, 2003 and March 6, 2003; and

Resolution 3-03 (Page 3)

WHEREAS, public comments have been received and duly considered on this date; and

NOW THEREFORE BE IT RESOLVED, that the Warren County Regional Planning Commission hereby adopts the above amendments to the Warren County Official Thoroughfare Plan, subject also to the following stipulations:

- 1. Alignments shown on the Functional Classification Map (Figure #4.1) are schematic, with the actual alignments to be determined during the review of development proposals; and
- 2. References to "Bikeway" Map shall be changed to "Pathway" in Figure #4.17 and on all Typical Street Sections, as applicable; a proposed separated path shall be shown along Tylersville Road in Figure #4.17; and American Association of State Highway and Transportation Officials (AASHTO) guidelines shall apply to pathways; and
- 3. The Warren County Engineer shall appropriately amend and distribute the Thoroughfare Plan text and exhibits.

Richard Renneker, Chairman
Warren County Regional Planning Commission

ATTEST:

Robert T. Craig, AICP, Executive Director
Warren County Regional Planning Commission

Date: March 11, 2003

L:/rtc/T-Plan.Resol.March03



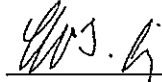
Resolution No. 3-04 (Page 3)

1. Dedication of public rights-of-way and public utility easements per the Hopkinsville 2010 Access Management Plan adopted alignment.
2. Line, grade and typical plans for the Road B portion of the Hopkinsville 2010 Access Management Plan shall be developed. The developer shall pay for a portion of the costs of the line, grade, and typical plans for Road B based upon a straight line mileage percentage.



 James Lukas, Chairman
 Warren County Regional Planning Commission

ATTEST:



 Robert T. Craig, AICP, Executive Director
 Warren County Regional Planning Commission

Date: April 13, 2004

L:/rtc/T-Plan.Resol.Apr04

**RESOLUTION No. 1-06
 ADOPTING CERTAIN AMENDMENTS TO THE
WARREN COUNTY OFFICIAL THOROUGHFARE PLAN**

WHEREAS, according to Section 713.23 of the Ohio Revised Code (ORC), a regional planning commission may make studies, maps, plans, recommendations and reports concerning the physical environment, social, economic and governmental characteristics, functions, services and other aspects of the region; and

WHEREAS, a Warren County Official Thoroughfare Plan has existed since July 17, 1956, per Warren County Resolution 40-591; and

WHEREAS, the functions of a Thoroughfare Plan are to:

Designate a network of thoroughfares to carry both current levels of traffic and anticipated increases that will be generated by growth and development in the County; and

Organize vehicular traffic by function in order to minimize conflict and assure that traffic will be carried on adequately designated thoroughfares; and

Assure that adequate land for rights-of-way are provided for future corridor development; and

Integrate planning for the County circulation system with the larger regional transportation system; and

WHEREAS, the Warren County Regional Planning Commission (RPC), working in conjunction with the Warren County Engineer, Woolpert Consultants and a Task Force consisting of public and private interests, developed a major Warren County Official Thoroughfare Plan update, hosting County-wide public forums on November 15, 16 and 17, 1995, as well as a duly advertised public hearing opened on April 9, 1996, being continued to May 7, 1996 and July, 9, 1996, being adopted on that date; and

WHEREAS, subsequently, additional refinements to the Warren County Official Thoroughfare Plan were adopted as amendments in March, 2003 (Resolution 3-03) and in April, 2004 (Resolution 3-04); and

WHEREAS, additional amendments are currently proposed by the Warren County Engineer, as follows (also see attached) :



**RESOLUTION No. 5-06
ADOPTING CERTAIN AMENDMENTS TO THE
WARREN COUNTY OFFICIAL THOROUGHFARE PLAN**

WHEREAS, according to Section 713.23 of the Ohio Revised Code (ORC), a regional planning commission may make studies, maps, plans, recommendations and reports concerning the physical environment, social, economic and governmental characteristics, functions, services and other aspects of the region; and

WHEREAS, a Warren County Official Thoroughfare Plan has existed since July 17, 1956, per Warren County Resolution 40-591, as a component of the overall Warren County Comprehensive Plan; and

WHEREAS, the functions of a Thoroughfare Plan are to:

Designate a network of thoroughfares to carry both current levels of traffic and anticipated increases that will be generated by growth and development in the County; and

Organize vehicular traffic by function in order to minimize conflict and assure that traffic will be carried on adequately designated thoroughfares; and

Assure that adequate land for rights-of-way are provided for future corridor development; and

Integrate planning for the County circulation system with the larger regional transportation system; and

WHEREAS, the Warren County Regional Planning Commission (RPC), working in conjunction with the Warren County Engineer, Woolpert Consultants and a Task Force consisting of public and private interests, developed a major Warren County Official Thoroughfare Plan update, being adopted in July, 1996; and

WHEREAS, certain amendments and/or refinements to the Warren County Official Thoroughfare Plan were subsequently adopted in March, 2003, April, 2004, January and April, 2006; and

WHEREAS, in the opinion of the Warren County Engineer, additional amendments and/or refinements are currently necessary, including changes to the Roadway Functional Classifications (Figure 4.1) for all or

portions of the following roadways in the unincorporated areas: Bethany Road, Bowen Drive, Butler-Warren Road, Columbia Road, Dallasburg Road, Deardoff Road, Dixie Highway, Drake Road, Fields-Ertel Road, Harlan Road, King Avenue, Kings Mills Road, Kirby Road, Liberty-Keuter Road, Mason-Morrow-Milgrove Road, McLean Road, Natorp Boulevard, Parkway Drive, Snider Road, State Route 48, State Route 123, State Route 350, Stephens Road, Striker Road, Utica Road, Waynesville Road, and Wilkens Boulevard.

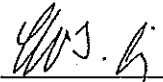
WHEREAS, a legal notice regarding a public hearing on this date was published in the newspaper of general circulation on March 30, and April 6, 2006; and

WHEREAS, public comments have been received and duly considered on this date; and

NOW THEREFORE BE IT RESOLVED, that the Warren County Regional Planning Commission hereby adopts the above amendments/refinements to the Warren County Official Thoroughfare Plan.


James Lukas, Chairman
Warren County Regional Planning Commission

ATTEST:


Robert T. Craig, AICP, Executive Director
Warren County Regional Planning Commission

Date: April 11, 2006

L:/rtc/T-Plan.Resol.Apr06

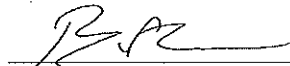
RESOLUTION NO. 06-11

APPROVE THE WARREN COUNTY COMPREHENSIVE PLAN AND TO MOVE
THE WARREN COUNTY COMPREHENSIVE PLAN TO THE WARREN COUNTY
COMMISSIONERS FOR APPROVAL

WHEREAS, according to Section 713.23 of the Ohio Revised Code (ORC), a regional
planning commission may make studies, maps, plans, recommendations and reports
concerning the physical environment, social, economic and governmental characteristics,
functions, services and other aspects of the region; and

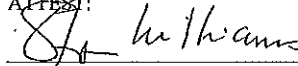
WHEREAS, the RPC has received and considered input from the steering committee,
interested citizens and business owners through notified public meetings;

NOW THEREFORE BE IT RESOLVED, that the RPC hereby approve The Warren
County Comprehensive Plan and to move the plan to the Warren County Commissioners
for approval.



Brian Lazor, Chairperson
Warren County Regional Planning Commission

ATTEST:



Stan Williams, Executive Director
Warren County Regional Planning Commission

Date: July 28, 2011

L:\Resolutions\2011\resolution 06-11 comprehensive plan

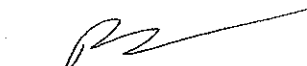
RESOLUTION NO. 10-11

APPROVE THE WARREN COUNTY COMPREHENSIVE PLAN AND TO MOVE
THE WARREN COUNTY COMPREHENSIVE PLAN TO THE WARREN COUNTY
COMMISSIONERS FOR APPROVAL

WHEREAS, according to Section 713.23 of the Ohio Revised Code (ORC), a regional
planning commission may make studies, maps, plans, recommendations and reports
concerning the physical environment, social, economic and governmental characteristics,
functions, services and other aspects of the region; and

WHEREAS, the RPC has received and considered input from the steering committee,
interested citizens and business owners through notified public meetings;

NOW THEREFORE BE IT RESOLVED, that the RPC hereby approve The Warren
County Comprehensive Plan and to move the plan to the Warren County Commissioners
for approval.



Brian Lazor, Chairperson
Warren County Regional Planning Commission

ATTEST:



Stan Williams, Executive Director
Warren County Regional Planning Commission

Date: October 11, 2011

L:\Resolutions\2011\resolution 10-11 comprehensive plan

Resolution

Number 19-1093

Adopted Date August 20, 2019

APPROVE AMENDMENT TO THE WARREN COUNTY COMPREHENSIVE PLAN TO
AMEND THE WAYNE TOWNSHIP FUTURE LAND USE MAP

WHEREAS, this Board met this 20th day of August 2019, in the Commissioners' Meeting Room to consider an amendment to the Warren County Comprehensive Plan to amend the Wayne Township Future Land Use Map; and

WHEREAS, this Board has considered the recommendation of the Regional Planning Commission and all those present to speak in favor of or in opposition to said amendment; and

NOW THEREFORE BE IT RESOLVED, to approve an amendment to the Warren County Comprehensive Plan to Amend the Wayne Township Future Land Use Map as attached hereto and made a part hereof.

Mr. Grossmann moved for adoption of the foregoing resolution being seconded by Mr. Young. Upon call of the roll, the following vote resulted:

Mrs. Jones - yea
Mr. Young - yea
Mr. Grossmann - yea

Resolution adopted this 20th day of August 2019.

BOARD OF COUNTY COMMISSIONERS

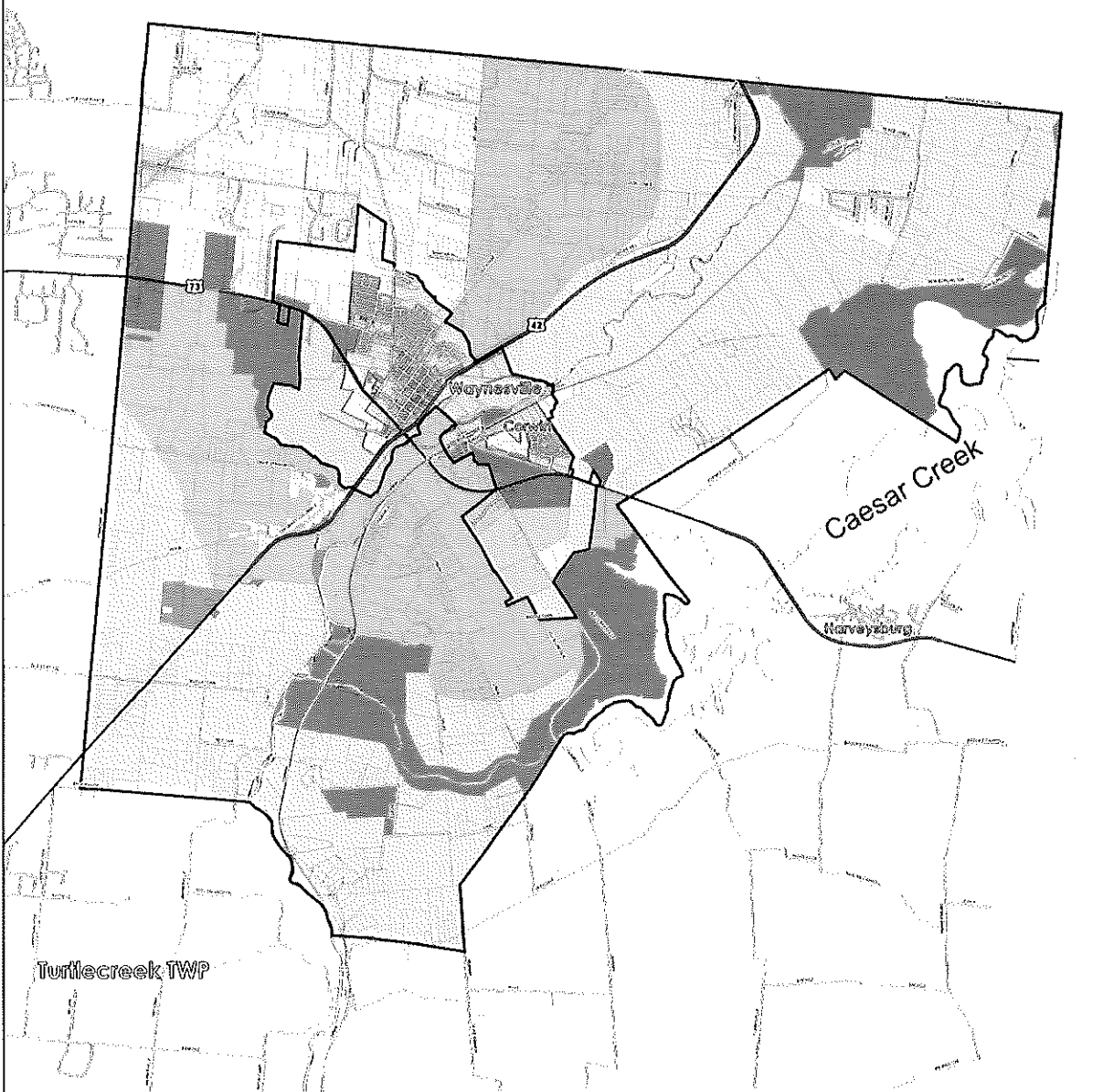


Tina Osborne, Clerk

/tao

cc: RPC
RZC (file)
Public Hearing file
Bruce McGary
Wayne Township Trustees

Wayne Township Future Land Use Map



<p>Future Land Use Designations</p> <ul style="list-style-type: none"> Agricultural Rural Residential Rural Neighborhoods Suburban Residential Mixed Use Residential Commercial Mixed Use Commercial/Industrial Public/ Semi-Public Recreation 		<p> Urban Service Area Boundary</p>
<p>0 0.3 0.6 1.2 1.8 2.4 Miles</p> <p>1 inch = 1,667 feet</p>		

Resolution

Number 19-1094

Adopted Date August 20, 2019

AUTHORIZING THE COUNTY ADMINISTRATOR TO EXECUTE THE GUARANTEED MAXIMUM PRICE AMENDMENT TO THE CONSTRUCTION MANAGER AT RISK SERVICES CONTRACT WITH GRANGER CONSTRUCTION COMPANY FOR THE NEW JAIL AND SHERIFF'S ADMINISTRATION OFFICE PROJECT ("PROJECT")

WHEREAS, pursuant to Resolution #18-0856, this Board of County Commissioners (the "Board") entered into an agreement with Granger Construction Co., Inc. (the "CMR") for preconstruction services for the Project, with the understanding that a guaranteed maximum price ("GMP") for construction of the Project was anticipated to be added to the agreement by amendment; and

WHEREAS, the CMR has completed the preconstruction services and has proposed a GMP of \$47,045,530 for construction of the Project; and

WHEREAS, said GMP presented includes the cost for subcontractor performance bonds which is currently under review by legal counsel and, if necessary, a GMP amendment will follow with the deduction of \$447,818; and

WHEREAS, the Board wishes to accept the CMR's GMP and authorize execution of the amendment adding the GMP to the existing agreement with the CMR.

NOW THEREFORE BE RESOLVED, that the Board accepts Granger Construction Co., Inc.'s GMP in the amount of \$47,045,530 and authorizes the Warren County Administrator and/or Deputy Administrator to execute the amendment to the agreement with Granger Construction Co., Inc. in substantially the form provided, with the GMP in the amount set forth in herein.

Mr. Young moved for adoption of the foregoing resolution being seconded by Mr. Grossmann. Upon call of the roll, the following vote resulted:

Mrs. Jones – yea
Mr. Grossmann – yea
Mr. Young – yea

Resolution adopted this 20th day of August 2019.

BOARD OF COUNTY COMMISSIONERS



Tina Osborne, Clerk

cc: C/A— Granger Construction Co., Inc
Sheriff (file)
Project file
Facilities Management (file)
Martin Russell

Resolution

Number 19-1095

Adopted Date August 20, 2019

AUTHORIZING THE ISSUANCE OF BONDS IN THE AMOUNT OF NOT TO EXCEED \$45,000,000 TO BE ISSUED FOR THE PURPOSE OF CONSTRUCTING, IMPROVING, FURNISHING, AND EQUIPPING A COUNTY JAIL AND SHERIFF FACILITY WITH RELATED SITE IMPROVEMENTS AND APPURTENANCES THERETO; AND AUTHORIZING AND APPROVING RELATED MATTERS

WHEREAS, the County Auditor of the County (the "Auditor") has certified to this Board that the estimated life of the project described in the title of this Resolution (the "Project"), which is to be financed from the proceeds of the bonds hereinafter described, exceeds five years and the maximum maturity of said bonds is 30 years; and

WHEREAS, it is now deemed necessary to issue and sell not to exceed \$45,000,000 of such bonds for the purpose described in the title of this Resolution under authority of the general laws of the State of Ohio, including Ohio Revised Code Chapter 133;

NOW, THEREFORE, BE IT RESOLVED BY THE BOARD OF COUNTY COMMISSIONERS OF THE COUNTY OF WARREN, OHIO THAT:

Section 1. Issuance of Bonds. It is hereby declared necessary to issue bonds of the County for the purpose described in the title of this Resolution in the principal sum of not to exceed \$45,000,000 or such lesser amount as shall be determined by the Auditor and certified to this Board, which bonds shall be designated "County of Warren, Ohio County Jail Construction and Improvement Bonds, Series 2019, " or as otherwise designated by the Auditor (the "Bonds"). The Bonds may be issued in one or more series.

Terms of Bonds. The Bonds shall be issued in fully registered, book-entry only format, without interest coupons, and shall be dated as determined by the Auditor. The Bonds shall be issued in denominations of \$5,000 or any multiple thereof and shall be numbered as determined by the Auditor. There shall be no charge for registration or transfer. The Bonds shall be negotiable instruments and shall bear interest at the rate or rates set forth in the Certificate of Fiscal Officer as authorized herein. The interest on the Bonds shall be payable on such dates (the "Interest Payment Dates") as shall be specified in the Certificate of Fiscal Officer, continuing until full payment of the principal amount of the Bonds has been made. The Bonds shall be scheduled to become due and payable in numerical order on such dates and in such annual principal amounts as shall be specified in the Certificate of Fiscal Officer.

Certificate of Fiscal Officer Relating to Terms of Bonds. The Auditor is hereby authorized and directed to execute on behalf of the County a Certificate of Fiscal Officer Relating to Terms of Bonds (the "Certificate of Fiscal Officer") setting forth the aggregate principal amount and the final terms of the Bonds, which aggregate principal amount and terms, subject to the limitations set forth in this Resolution, shall be as determined by the Auditor. The Certificate of Fiscal Officer shall indicate the dated date for the Bonds, the dates on which interest on the Bonds is to be paid (the "Interest Payment Dates"), the purchase price for the Bonds (which shall be not less than 97% of the aggregate principal amount thereof), the maturity schedule for the Bonds (provided that the maximum maturity date of the Bonds shall not exceed 30 years), the interest rates for the Bonds (provided that the true interest cost for all Bonds in the aggregate shall not exceed 5.00% per annum), and such other terms not inconsistent with this Resolution as the Auditor shall deem appropriate.

Redemption Provisions of the Bonds. The Bonds shall be subject to optional and mandatory redemption prior to stated maturity, as provided in the Certificate of Fiscal Officer. If optional redemption of the Bonds at a redemption price exceeding 100% is to take place on any date on which a mandatory redemption of the Bonds of the same maturity will take place, the Bonds to be redeemed by optional redemption shall be selected by the Bond Registrar (as defined hereinbelow), prior to the selection of the Bonds to be redeemed at par on the same date.

When partial redemption is authorized, the Bond Registrar shall select Bonds or portions thereof by lot within a maturity in such manner as the Bond Registrar may determine, provided, however, that the portion of Bonds so selected shall be in the amount of \$5,000 or any integral multiple thereof unless otherwise determined by the Auditor.

Any notice of the call for redemption of Bonds shall identify (i) by designation, letters, numbers or other distinguishing marks, the Bonds or portions thereof to be redeemed, (ii) the redemption price to be paid, (iii) the date fixed for redemption, and (iv) the place or places where the amounts due upon redemption are payable. From and after the specified redemption date interest on the Bonds (or portions thereof) called for redemption shall cease to accrue. Such notice shall be sent by first class mail at least 30 days prior to the redemption date to each registered holder of Bonds to be redeemed at the address shown in the Bond Register on the 15th day preceding the date of mailing. Failure to receive such notice of any defect therein shall not affect the validity of the proceedings for the redemption of any Bond.

Form and Execution of the Bonds. The Bonds shall express upon their faces the purpose for which they are issued and that they are issued pursuant to this Resolution. The Bonds shall be executed by the Auditor and not less than two of the County Commissioners of the County (the "County Commissioners"), in their official capacities, provided that any of their signatures may be a facsimile. No Bond shall be valid or become obligatory for any purpose or shall be entitled to any security or benefit under this Resolution unless and until a certificate of authentication, as printed on the Bond, is signed by the Bond Registrar as authenticating agent. Authentication by the Bond Registrar shall be conclusive evidence that the Bond so authenticated has been duly issued and delivered under this Resolution and is entitled to the security and benefit of this Resolution. The certificate of authentication may be signed by any officer or officers of the Bond Registrar or by such other person acting as an agent of the Bond Registrar as shall be approved by the Auditor on behalf of the County. It shall not be necessary that the same authorized person sign the certificate of authentication on all of the Bonds.

Payment of the Bonds. The principal of and interest on the Bonds shall be payable in lawful money of the United States of America without deduction for the services of the Bond Registrar as paying agent. The principal of the Bonds shall be payable upon presentation and surrender of the Bonds at the principal office of the Bond Registrar, or as otherwise determined by the Auditor in the Certificate of Fiscal Officer. Each Bond shall bear interest from the later of the date thereof, or the most recent Interest Payment Date to which interest has been paid or duly provided for, unless the date of authentication of any Bond is less than 15 days prior to an Interest Payment Date, in which case interest shall accrue from such Interest Payment Date. Interest on any Bond shall be paid on each Interest Payment Date by check or draft mailed to the person in whose name the Bond is registered, at the close of business on the 15th day next preceding that Interest Payment Date (the "Record Date") (unless such date falls on a non-business day, in which case the Record Date shall be the preceding business day), on the Bond Register at the address appearing therein.

Any interest on any Bond which is payable, but is not punctually paid or provided for, on any Interest Payment Date (herein called "Defaulted Interest") shall forthwith cease to be payable to the registered owner on the relevant Record Date by virtue of having been such owner and such Defaulted Interest shall be paid to the registered owner in whose name the Bond is registered at the close of business on a date (the "Special Record Date") to be fixed by the Bond Registrar, such Special Record Date to be not more than 15 nor less than 10 days prior to the date of proposed payment. The Bond Registrar shall cause notice of the proposed payment of such Defaulted Interest and the Special Record Date therefor to be mailed, first class postage prepaid, to each Bondholder, at such Bondholder's address as it appears in the Bond Register, not less than 10 days prior to such Special Record Date, and may, in its discretion, cause a similar notice to be published once in a newspaper in each place where Bonds are payable, but such publication shall not be a condition precedent to the establishment of such Special Record Date.

Subject to the foregoing provisions of this Section, each Bond delivered by the Bond Registrar upon transfer of or in exchange for or in lieu of any other Bond shall carry the rights to interest accrued and unpaid, and to accrue, which were carried by such other Bond.

Appointment of Bond Registrar. The Auditor is hereby authorized and directed to serve as authenticating agent, Bond Registrar, transfer agent, and paying agent (collectively, the "Bond Registrar") for the Bonds or to execute on behalf of the Board a Bond Registrar Agreement with such bank or other appropriate financial institution as shall be acceptable to the Auditor and the Original Purchaser, pursuant to which such bank or financial institution shall agree to serve as Bond Registrar for the Bonds. If at any time the Bond Registrar shall be unable or unwilling to serve as such, or the Auditor in such officer's discretion shall determine that it would be in the best interest of the County for such functions to be performed by another party, the Auditor may, and is hereby authorized and directed to, enter into an agreement with a national banking association or other appropriate institution experienced in providing such services to perform the services required of the Bond Registrar hereunder. Each such successor Bond Registrar shall promptly advise all bondholders of the change in identity and new address of the Bond Registrar. So long as any of the Bonds remain outstanding, the County shall cause to be maintained and kept by the Bond Registrar, at the office of the Bond Registrar, all books and records necessary for the registration, exchange and transfer of Bonds as provided in this Section (the "Bond Register"). Subject to the provisions hereof, the person in whose name any Bond shall be registered on the Bond Register shall be regarded as the absolute owner thereof for all purposes. Payment of or on account of the principal of and interest on any Bond shall be made only to or upon the order of that person. Neither the County nor the Bond Registrar shall be affected by any notice to the contrary, but the registration may be changed as herein provided. All payments shall be valid and effectual to satisfy and discharge the liability upon the Bonds, including the interest thereon, to the extent of the amount or amounts so paid.

Any Bond, upon presentation and surrender at the office of the Bond Registrar, together with a request for exchange signed by the registered owner or by a person authorized by the owner to do so by a power of attorney in a form satisfactory to the Bond Registrar, may be exchanged for Bonds of the same form and of any authorized denomination or denominations equal in the aggregate to the unmatured principal amount of the Bonds surrendered, and bearing interest at the same rate and maturing on the same date.

A Bond may be transferred only on the Bond Register upon presentation and surrender thereof at the office of the Bond Registrar, together with an assignment executed by the registered owner or by a person authorized by the owner to do so by a power of attorney in a form satisfactory to the Bond Registrar. Upon that transfer, the Bond Registrar shall complete, authenticate and deliver a new Bond or Bonds of any

authorized denomination or denominations equal in the aggregate to the unmatured principal amount of the Bonds surrendered, and bearing interest at the same rate and maturing on the same date.

The County and the Bond Registrar shall not be required to transfer or exchange (i) any Bond during a period beginning at the opening of business 15 days before the day of mailing of a notice of redemption of Bonds, and ending at the close of business on the day of such mailing, or (ii) any Bonds selected for redemption, in whole or in part, following the date of such mailing.

In all cases in which Bonds are exchanged or transferred hereunder, the County shall cause to be executed and the Bond Registrar shall authenticate and deliver Bonds in accordance with the provisions of this Resolution. The exchange or transfer shall be without charge to the owner; except that the County and the Bond Registrar may make a charge sufficient to reimburse them for any tax or other governmental charge required to be paid with respect to the exchange or transfer. The County or the Bond Registrar may require that those charges, if any, be paid before it begins the procedure for the exchange or transfer of the Bonds. All Bonds issued upon any transfer or exchange shall be the valid obligations of the County, evidencing the same debt, and entitled to the same benefits under this Resolution, as the Bonds surrendered upon that transfer or exchange.

Book-Entry System. For purposes of this Resolution, the following terms shall have the following meanings:

"Book-entry form" or "book-entry system" means a form or system under which (i) the beneficial right to payment of principal of and interest on the Bonds may be transferred only through a book-entry and (ii) physical Bonds in fully registered form are issued only to the Depository or its nominee as registered owner, with the Bonds "immobilized" to the custody of the Depository, and the book-entry is the record that identifies the owners of beneficial interests in those Bonds.

"Depository" means any securities depository that is a clearing agency under federal law operating and maintaining, together with its participants, a book-entry system to record beneficial ownership of Bonds and to effect transfers of Bonds, in book-entry form, and includes The Depository Trust Company (a limited purpose trust company), New York, New York.

All or any portion of the Bonds may be initially issued to a Depository for use in a book-entry system, and the provisions of this Section shall apply, notwithstanding any other provision of this Resolution; (i) there shall be a single Bond of each maturity, (ii) those Bonds shall be registered in the name of the Depository or its nominee, as registered owner, and immobilized in the custody of the Depository; (iii) the beneficial owners in book-entry form shall have no right to receive Bonds in the form of physical securities or certificates; (iv) ownership of beneficial interests in any Bonds in book-entry form shall be shown by book-entry on the system maintained and operated by the Depository, and transfers of the ownership of beneficial interests shall be made only by the Depository and by book-entry; and (v) the Bonds as such shall not be transferable or exchangeable, except for transfer to another Depository or to another nominee of a Depository, without further action by the County. Bond service charges on Bonds in book-entry form registered in the name of a Depository or its nominee shall be payable in next day funds delivered to the Depository or its authorized representative (i) in the case of interest, on each Interest Payment Date, and (ii) in all other cases, upon presentation and surrender of Bonds as provided in this Resolution.

The Bond Registrar may, with the approval of the County, enter into an agreement with the beneficial owner or registered owner of any Bond in the custody of a Depository providing for making all payments to that owner of principal and interest on that Bond or any portion thereof (other than any payment of the entire unpaid principal amount thereof) at a place and in a manner (including wire transfer of federal funds) other than as provided above in this Resolution, without prior presentation or surrender of the Bond, upon any conditions which shall be satisfactory to the Bond Registrar and to the County. That payment in any event shall be made to the person who is the registered owner of that Bond on the date that principal is due, or, with respect to the payment of interest, as of the applicable date agreed upon as the case may be. The Bond Registrar shall furnish a copy of each of those agreements, certified to be correct by the Bond Registrar, to other paying agents for Bonds and to the County. Any payment of principal or interest pursuant to such an agreement shall constitute payment thereof pursuant to, and for all purposes of, this Resolution.

If requested, the Auditor and any of the County Commissioners are authorized and directed to execute, acknowledge and deliver, in the name of and on behalf of the County, the letter agreement among the County, the Bond Registrar and The Depository Trust Company, as depository, to be delivered in connection with the issuance of the Bonds to the Depository for use in a book-entry system in substantially the form submitted to this Board.

The County may decide to discontinue use of the book-entry system through the Depository. In that event, Bond certificates will be printed and delivered to the Depository.

If any Depository determines not to continue to act as a depository for the Bonds for use in a book-entry system, the County and the Bond Registrar may attempt to establish a securities depository/book-entry relationship with another qualified Depository under this Resolution. If the County and the Bond Registrar do not or are unable to do so, the County and the Bond Registrar, after the Bond Registrar has made provision for notification of the beneficial owners by the then Depository, shall permit withdrawal of the Bonds from the Depository and authenticate and deliver bond certificates in fully registered form to the assigns of the Depository or its nominee, all at the cost and expense (including costs of printing definitive Bonds), if the event is not the result of action or inaction by the County or the Bond Registrar, of those persons requesting such issuance.

Debt Service Levy. There shall be and is hereby levied annually on all the taxable property in the County, in addition to all other taxes and inside the ten mill limitation, a direct tax (the "Debt Service Levy") for each year during which any of the Bonds are outstanding, for the purpose of providing, and in an amount which is sufficient to provide, funds to pay interest upon the Bonds as and when the same falls due and to provide a fund for the repayment of the principal of the Bonds at maturity or upon redemption. The Debt Service Levy shall not be less than the interest and sinking fund tax required by Article XII, Section 11 of the Ohio Constitution.

The Debt Service Levy shall be and is hereby ordered computed, certified, levied and extended upon the tax duplicate and collected by the same officers, in the same manner, and at the same time that taxes for general purposes for each of such years are certified, extended and collected. The Debt Service Levy shall be placed before and in preference to all other items and for the full amount thereof. The funds derived from the Debt Service Levy shall be placed in a separate and distinct fund, which shall be irrevocably pledged for the payment of the premium, if any, and interest on and principal of the Bonds when and as the same fall due. Notwithstanding the foregoing, if the County determines that funds will be available from other sources for the payment of the Bonds in any year, the amount of the Debt Service Levy

for such year shall be reduced by the amount of funds which will be so available, and the County shall appropriate such funds to the payment of the Bonds in accordance with law.

Sale of the Bonds. The Bonds shall be sold at private sale to Fifth Third Securities, Inc., Cincinnati, Ohio and KeyBanc Capital Markets Inc., Columbus, Ohio (collectively, the "Original Purchaser") at the purchase price set forth in the Certificate of Fiscal Officer, plus interest accrued to the date of delivery to said Original Purchaser. The administrator of the County (the "County Administrator"), Auditor, County Commissioners, or any of them individually, are each authorized and directed to execute on behalf of the County a Bond Purchase Agreement with the Original Purchaser, setting forth the conditions under which the Bonds are to be sold and delivered, which agreement shall not be substantially inconsistent with the form heretofore presented to the Board.

The proceeds from the sale of the Bonds, except the premium and accrued interest thereon, shall be used for the purpose aforesaid and for no other purpose. Any accrued interest received from such sale shall be transferred to the bond retirement fund to be applied to the payment of the principal of and interest on the Bonds, or other obligations of the County, as permitted by law. Any premium from the sale of the Bonds may be used to pay the financing costs of the Bonds within the meaning of Ohio Revised Code Section 133.01(K) or be deposited into the bond retirement fund.

Federal Tax Law Compliance. The Board hereby covenants that it will comply with the requirements of all existing and future laws which must be satisfied in order that interest on the Bonds is and will continue to be excluded from gross income for federal income tax purposes, including without limitation restrictions on the use of the property financed with the proceeds of the Bonds so that the Bonds will not constitute "private activity bonds" within the meaning of Section 141 of the Internal Revenue Code of 1986, as amended (the "Code"). The Board further covenants that it will restrict the use of the proceeds of the Bonds in such manner and to such extent, if any, as may be necessary, after taking into account reasonable expectations at the time the Bonds are issued, so that they will not constitute arbitrage bonds under Section 148 of the Code and the regulations prescribed thereunder (the "Regulations").

The County Administrator, Auditor, or any other officer of this Board, is hereby authorized and directed (a) to make or effect any election, selection, designation, choice, consent, approval or waiver on behalf of the Board with respect to the Bonds as permitted or required to be made or given under the federal income tax laws, for the purpose of assuring, enhancing or protecting favorable tax treatment or the status of the Bonds or interest thereon or assisting compliance with requirements for that purpose, reducing the burden or expense of such compliance, reducing any rebate amount or any payment of penalties, or making any payments of special amounts in lieu of making computations to determine, or paying, any excess earnings as rebate, or obviating those amounts or payments, as determined by the Auditor, which action shall be in writing and signed by the Auditor, or any other officer of this Board, on behalf of the Board; (b) to take any and all actions, make or obtain calculations, and make or give reports, covenants and certifications of and on behalf of the Board as may be appropriate to assure the exclusion of interest from gross income and the intended tax status of the Bonds; and (c) to give an appropriate certificate on behalf of the Board, for inclusion in the transcript of proceedings, setting forth the facts, estimates and circumstances, and reasonable expectations of the Board pertaining to Section 148 and the Regulations, and the representations, warranties and covenants of the Board regarding compliance by the Board with Sections 141 through 150 of the Code and the Regulations.

The Auditor shall keep and maintain adequate records pertaining to the use and investment of all proceeds of the Bonds sufficient to permit, to the maximum extent possible and presently foreseeable, the County to comply with any federal law or regulation now or hereafter having applicability to the Bonds that relates to the use of such proceeds, which limits the amount of bond proceeds which may be invested on an unrestricted yield or requires the County to rebate arbitrage profits to the United States Department of the Treasury. The Auditor is hereby authorized and directed to file such reports with, and rebate arbitrage profits to, the United States Department of the Treasury, to the extent that any federal law or regulation having applicability to the Bonds requires any such reports or rebates.

Official Statement. The distribution of an Official Statement of the County, in preliminary and final form, relating to the original issuance of the Bonds is hereby authorized, and the County Administrator, Auditor and County Commissioners are hereby authorized and directed to negotiate, prepare and execute, on behalf of the County and in their official capacity, the Official Statement and any supplements thereto as so executed in connection with the original issuance of the Bonds, and they are authorized and directed to advise the Original Purchaser in writing regarding limitations on the use of the Official Statement and any supplements thereto for purposes of marketing or reoffering the Bonds as they deem necessary or appropriate to protect the interests of the County. The County Administrator, Auditor and County Commissioners are each authorized to execute and deliver, on behalf of the County and in their official capacities, such certificates in connection with the accuracy of the Official Statement, in either preliminary or final form, and any supplements thereto as may, in their judgment, be necessary or appropriate.

Municipal Bond Insurance. The County Administrator, Auditor and County Commissioners are authorized and directed to consult with the Municipal Advisor (as defined below) regarding the advisability of obtaining municipal bond insurance to enhance the credit of the Bonds. If in the opinion of such officials, obtaining municipal bond insurance will produce a net interest cost savings to the County, then such officials shall arrange for the purchase of such municipal bond insurance and payment therefor from proceeds of the Bonds. The Auditor is authorized and directed to execute on behalf of the County any and all agreements, contracts, and documents necessary or appropriate in its discretion to effectuate such insurance and to state the terms thereof in the Certificate of Fiscal Officer, as appropriate.

Obtaining of Rating for the Bonds. The obtaining or updating of a rating or ratings on the Bonds and the County is hereby authorized if the County Administrator, Auditor and County Commissioners determine that it is necessary or advisable in connection with the original issuance of the Bonds. If such officials so determine, then the County Administrator, Auditor and County Commissioners are hereby authorized and directed to take all steps necessary to obtain such rating or ratings.

Appointment of Municipal Advisor. The County Administrator, on behalf of this Board, is hereby authorized to appoint the firm of Bradley Payne Advisors, LLC to serve as municipal advisor to the County in connection with the issuance of the Bonds. The fees to be paid to such firm shall be subject to review and approval of the County Administrator and shall not exceed the fees customarily charged for such services.

Appointment of Bond Counsel. The Board hereby approves the appointment of the law firm of Bricker & Eckler LLP to serve as bond counsel to the County with respect to the issuance of the

Bonds. The fees to be paid to such firm shall be subject to review and approval by the County Administrator and shall not exceed the fees customarily charged for such services.

Transcript of Proceedings; Execution of Additional Documents. The officer having charge of the minutes of the Board and any other officers of the Board or the County, or any of them individually, are hereby authorized and directed to prepare and certify a true transcript of proceedings pertaining to the Bonds and to furnish a copy of such transcript to the Original Purchaser. Such transcript shall include certified copies of all proceedings and records of the Board relating to the power and authority of the County to issue the Bonds and certificates as to matters within their knowledge or as shown by the books and records under their custody and control, including but not limited to a general certificate of the Clerk of the Board and a no-litigation certificate of not less than two of the County Commissioners and the Auditor, and such certified copies and certificates shall be deemed representations of the County as to the facts stated therein.

The members of this Board, the Auditor, and any other officer of the County (or any of them individually) are hereby authorized and directed to take such action (including, but not limited to, hiring bond counsel and such other professionals or consultants as may be needed to facilitate the issuance of the Bonds) and to execute and deliver, on behalf of the Board, such additional instruments, agreements, certificates, and other documents as may be in their discretion necessary or appropriate in order to carry out the intent of this Resolution. Such documents shall be in the form not substantially inconsistent with the terms of this Resolution, as they in their discretion shall deem necessary or appropriate.

Satisfaction of Conditions for Bond Issuance. It is hereby found and determined that all acts, conditions and things necessary to be done precedent to and in the issuing of the Bonds in order to make them legal, valid and binding obligations of the County have happened, been done and been performed in regular and due form as required by law; that the full faith, credit and revenue of the County are hereby irrevocably pledged for the prompt payment of the principal and interest thereof at maturity; and that no limitation of indebtedness or taxation, either statutory or constitutional, has been exceeded in issuing the Bonds.

Compliance with Open Meeting Requirements. It is hereby found and determined that all formal actions of this Board concerning and relating to the passage of this Resolution were taken in an open meeting of this Board, and that all deliberations of this Board and of any of its committees that resulted in such formal action were in meetings open to the public in compliance with all legal requirements, including Ohio Revised Code Section 121.22.

Filing of Bond Resolution. The Clerk of the Board of is hereby directed to forward a certified copy of this Resolution to the Auditor.

Effective Date. This Resolution shall take effect and be in force at the earliest date permitted by law.

Mr. Grossmann moved for adoption of the foregoing resolution being seconded by Mr. Young.
Upon call of the roll, the following vote resulted:

Mrs. Jones – yea
Mr. Young – yea
Mr. Grossmann – yea

Resolution adopted this 20th day of August 2019.

BOARD OF COUNTY COMMISSIONERS

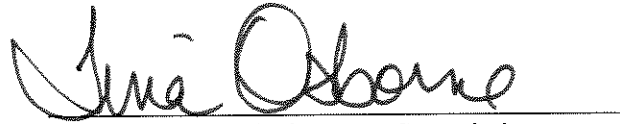

Tina Osborne, Clerk

/tao

cc: Auditor (certified)
Bond File
Project file

CERTIFICATE

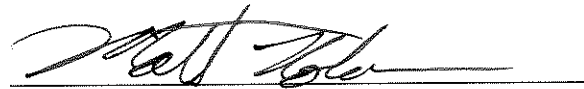
The undersigned Clerk of the Board of County Commissioners hereby certifies that the foregoing is a true copy of a resolution duly passed by the Board of County Commissioners of the County of Warren, Ohio on August 20, 2019 and that a true copy thereof was certified to the County Auditor of the County of Warren, Ohio.


Clerk of the Board of County Commissioners
County of Warren, Ohio

**RECEIPT OF COUNTY AUDITOR FOR
LEGISLATION PROVIDING
FOR THE ISSUANCE OF
GENERAL OBLIGATION BONDS**

I, Matt Nolan, the duly elected, qualified, and acting County Auditor in and for the County of Warren, Ohio, hereby certify that a certified copy of a resolution duly passed by the Board of County Commissioners of the County of Warren County, Ohio on August 20, 2019 providing for the issuance of general obligation bonds designated "County of Warren, Ohio County Jail Construction and Improvement Bonds, Series 2019," or as otherwise designated by the County Auditor, in the amount of not to exceed \$45,000,000 was filed in this office on Aug. 20th, 2019.

WITNESS my hand and official seal at Lebanon, Ohio this Aug. 20th, 2019.



County Auditor
County of Warren, Ohio

[SEAL]

BOARD OF COUNTY COMMISSIONERS
WARREN COUNTY, OHIO

Resolution

Number 19-1096

Adopted Date August 20, 2019

APPROVE APPROPRIATION ADJUSTMENT WITHIN COUNTY COURT FUND #1101

BE IT RESOLVED, to approve the following appropriation adjustment within County Court Fund 1101

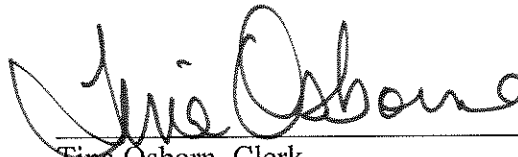
\$ 1500.00	from	#11011280 5210	(MATERIALS & SUPPLIES)
	into	#11011280 5400	(PURCHASED SERVICES)

Mr. Grossmann moved for adoption of the foregoing resolution, being seconded by Mr. Young. Upon call of the roll, the following vote resulted:

Mrs. Jones - yea
Mr. Young - yea
Mr. Grossmann - yea

Resolution adopted this 20th day on August 2019.

BOARD OF COUNTY COMMISSIONERS



Tina Osborn, Clerk

Cc: Auditor _____
Appropriation Adjustment file
County Court (file)
OMB